

## The Profile System

# The key to success!



## MayTec System Technology

### Solutions with Innovative Profile

#### Applications

- machine bases
- machine enclosures
- machine guarding
- work stations
- assembly and inspection stations
- transfer and supply trolleys
- partitions and protective walls
- protective and work cabins
- special shelves
- plant equipment
- display systems
- exhibition cabinets and stands

#### Service

The MayTec service is as versatile as the MayTec profile system.

You may choose:

- delivery of standard elements ex factory
- delivery of profiles and accessories cut to size according to parts list for customer's assembly
- delivery of pre-fitted modular
- delivery of completely assembled units
- assembly at your premises

#### Implementation

The MayTec profile system is easy to process and quick to assemble. Its flexible and modular construction means it can be easily modified and is reusable at any time.

An experienced team will support you in implementing the MayTec system, tailored to your individual applications, taking into consideration your required dimensions, loading capacity and stability.



The Profile System

#### The ideal profile system

MayTec offers a comprehensive, harmonised profile system. All profiles can be combined in any way imaginable.

The accessories provide functional and aesthetic solutions for a wide range of applications.



The Clean-Room System



The Tube Clamping System



Work Benches



The Linear System



The Conveyor System



Safety Barriers



Suspended Trolley System

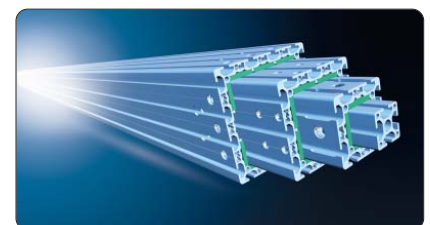

The Telescopic System

	Table of contents	
	Introduction	1.0
<b>Profiles</b>	<b>Summary</b>	
	Profiles	1.1
	Profile machining	1.1A
	- Coding examples	1.1B
	Technical data	1.1C
	Profile selection range	1.1D
	Profile applications	1.1E
	- Bent profiles	1.1E
<b>Connection system</b>	<b>Summary</b>	
	Connector selection	1.2
	Connectors	1.2A
	- Cross bushings	1.2B
	- Components	1.2C
	- Special cases	1.2D
	Connection possibilities	1.2E
	Connector-Strength values	1.2F
	Connection elements	1.29
<b>Accessories</b>	<b>Summary</b>	
	Fastening elements	1.3
	Installation accessories	1.4
	Pneumatic accessories	1.5
	Additional accessories	1.6
	Electrical accessories	1.7
	Panel elements	1.8
	Tools	1.9
<b>General information</b>		
	CAD-Library	1.A
	Conversion tables	1.B
	Subject index	

0

1

2

3

4

5

6

7

8

9

A

B

Article number group	Page	Article number group	Page
		<b>Introduction</b> .....	<b>5</b>
1.01	5	1.1C	65
1.02	6	1.1D	68
1.03	7	1.1E	72
		1.1E.01	72
<b>1.1 Profiles</b> .....	<b>8</b>	1.1E.01	72
1.04	8	1.1E.02	73
1.04	8, 9	1.1E.03	76
1.04	9	1.1E.04	77
1.04	10	1.1E.05	78
1.05	11	1.1E.06	79
1.09	12	1.1E.07	82
1.10	12		
1.10	13	<b>1.2 Connection System</b> .....	<b>83</b>
1.11	15	1.2	85
1.11	16	1.2	86
1.11	20	1.2	86
1.11	28	1.2	86
1.11	31	1.2	89
1.11	32	1.2	89
1.11	33	1.2	90
1.11	34	1.2A	91
1.11	36	1.2A	91
1.11	40	1.2A	93
1.11	40	1.2B	99
1.11	42	1.2B	99
1.11	44	1.2B	99
1.15	45	1.2B	100
1.15	46	1.2B	100
1.15	46	1.2C	101
5.11	47	1.2C	101
8.11	48	1.2C	102
9.11	49	1.2C	102
1.19	50	1.2D	106
1.19	50	1.2D	106
1.19	50	1.2D	106
1.19	50	1.2D	106
1.19	51	1.2D	107
1.19	51	1.2D	107
1.19	51	1.2D	108
1.19	51	1.2D	108
1.19	52	1.2D	109
1.19	52	1.2D	109
1.19	52	1.2D	110
1.19	52	1.2D	110
1.19	53	1.2D	111
1.19	53, 54	1.2D	111
1.19	54	1.2D	112
1.19	54	1.2D	112
1.19	55	1.2D	113
1.19	55	1.2D	113
1.19	55	1.2D	115
1.19	56	1.2D	115
1.1A	58	1.2D	116
1.1A	58	1.2D	116
1.1A	58	1.2D	117
1.1A	58	1.2E	118
1.1A	59	1.2E	118
1.1A	60	1.2E	118
1.1A	60	1.2E	124
1.1A	60	1.2E	124
1.1A	60	1.2E	125
1.1A	60	1.2E	125
1.1A	60	1.2E	126
1.1A	60	1.2E	126
1.1A	60	1.2F	127
1.1A	60	1.2F	127
1.1A	61	1.29	128
1.1A	61	1.29	128
1.1A	61	1.29	128
1.1A	61	1.29	129
1.1A	61	1.29	129
1.1A	61	1.29	131
1.1B	62		
1.1B	62	<b>Accessories</b> .....	<b>132</b>
1.1B	63	Summary: Accessories .....	132
1.1B	64		
1.1B	64	<b>1.3 Fastening elements</b> .....	<b>135</b>
1.1B	64	1.31	135
		1.32	138
		1.33	141
		1.34	142
		1.34	143
		1.34	144

Article number group	Page	Article number group	Page
1.35	Threaded inserts .....	145	
1.35	Press-fit threaded inserts .....	147	
<b>1.4</b>	<b>Installation accessories .....</b>	<b>149</b>	
1.41	Cover profiles .....	149	
1.41	Reducing profiles .....	150	
1.41	Combination profiles .....	151	
1.41	Guide profile .....	155	
1.41	Framing profiles .....	156, 161	
1.41	Wedge profiles .....	157	
1.41	Sponge rubber round cords .....	158	
1.41	Sealing profile .....	160	
1.41	Rubber cover-profiles .....	163	
1.42	Cover caps for profiles .....	164	
1.42	Cover plugs for cross bushings .....	167	
1.42	Cover caps for tubes .....	168	
1.42	Cover caps for screw bores .....	168	
1.43	Radius covers .....	169	
1.43	Radius compensations .....	171	
1.44	Floor levelling screws .....	172	
1.44	Levelling feet .....	172, 174	
1.44	Hand adjustable feet .....	173	
1.44	Levelling furniture foot .....	174	
1.44	Adjustable tilt-feet .....	175	
1.44	plates .....	176	
1.44	spindles .....	178	
1.44	nuts .....	178	
1.44	anti-slip discs .....	179	
1.44	cushion elements .....	179	
1.44	Angular adjusting feet .....	180	
1.44	Base feet .....	181	
1.44	Base angle .....	187	
1.44	Stacking foot .....	187	
1.45	Castors .....	188	
1.45	Fixed castors .....	188	
1.45	Swivel castors .....	189	
1.45	Swivel castors lockable .....	189	
1.45	Locking castors .....	190	
1.46	Angles .....	192	
1.46	Aluminium .....	192, 201	
1.46	PA .....	193	
1.46	GD-Zn .....	194	
1.46	GD-Al .....	200	
1.46	Swivel angles .....	202	
1.47	Cross connection plates .....	203	
1.47	Base plates .....	204	
1.47	Floor mounting plate .....	205	
1.47	Mounting plates .....	206	
1.47	Floor plate .....	206	
1.47	Connection plates .....	207	
1.47	Fastening plate .....	208	
1.47	Eye bolt .....	209	
1.48	Corner pieces .....	210	
1.48	GD-Zn .....	210	
1.48	Aluminium .....	212	
<b>1.5</b>	<b>Pneumatic accessories .....</b>	<b>214</b>	
1.51	Profiles for pneumatic applications .....	214	
1.51	Pneumatic end plates .....	215	
1.52	Pneumatic connection plates .....	217	
1.54	Pneumatic extension sets .....	218	
1.55	Pneumatic 90° - connection sets .....	219	
1.59	Pneumatic accessories .....	220	
<b>1.6</b>	<b>Additional accessories .....</b>	<b>221</b>	
1.61	Handles .....	221	
1.61	Handle systems .....	223	
1.61	Grab handles .....	225	
1.62	Hinges .....	226	
1.62	Double hinge .....	232	
1.63	Joints .....	242	
1.64	Mounting blocks .....	245	
1.64	Mounting clamp blocks .....	249	
1.64	Quick locks .....	252	
1.65	Bullet catches .....	254	
1.65	Magnetic lock .....	256	
1.65	Lock .....	257	
1.65	Cylinder locks .....	258	
1.65	Flap-lock countersunk .....	260	
1.65	Cylinder locks flush .....	260	
1.65	Mortise deadlocks .....	262	
1.65	Bar locks .....	266	
1.65	Latch locks .....	270	
1.66	Rollers .....	271	
1.66	Roller fastening sets .....	273	
1.66	Mounting adaptor for roller .....	277	
1.66	Edge roller .....	278	
1.66	Roller fitting for suspended doors .....	279	
1.66	Stopper for suspended doors .....	280	
1.66	Accessories for suspended doors .....	280	
1.66	Runner for sliding suspended doors .....	281	
1.66	Stopper for sliding suspended doors .....	282	
1.67	Slot rollers .....	283	
1.67	Guidance system .....	284	
1.67	Sliding blocks .....	285	
1.67	T-Nut sliding blocks .....	286	
1.67	Eco-Slides .....	287	
1.68	Hanging bracket .....	291	
1.69	Suspended glider .....	292	
1.69	Carabine swivel .....	292	
<b>1.7</b>	<b>Electrical accessories .....</b>	<b>293</b>	
1.70	Potential equalisation, grounding connectors .....	293	
1.70	Ground connections .....	294	
1.71	Cable and hose clamp .....	295	
1.71	Block for cable binder .....	296	
1.71	Cross-blocks for cable binder .....	296	
1.71	Cable binder .....	296	
1.71	Installation rings .....	297	
1.72	Mounting set for 19" profile .....	298	
1.73	Safety switches .....	299	
1.73	Guard locking devices .....	300	
1.73	Safety interlocking-mountings .....	301	
1.73	Contact bracket-mounting .....	302, 305	
1.73	Sensor brackets .....	306	
1.74	Electrical installation trunking .....	307	
1.74	Electrical installation trunking - Accessories .....	308	
1.75	Electrical installation trunking .....	311	
<b>1.8</b>	<b>Panel elements .....</b>	<b>314</b>	
1.81	Corner elements .....	314	
1.81	Corner element 33 .....	315	
1.81	Mounting sockets .....	316	
1.82	Panel elements .....	317	
1.82	Chipboards, coated .....	318	
1.83	Solid plastic panels .....	318	
1.85	Alu-plastic composite panels .....	320	

Article number group	Page
1.86	Acrylic ..... 320
1.87	Polycarbonate (Makrolon) ..... 320
1.88	Wire net, Alu ..... 321
1.88	Wire net, steel ..... 321
1.88	Grid, steel ..... 322
<b>1.9</b>	<b>Tools ..... 323</b>
1.90	Button head screws ..... 323
1.98	Press in device ..... 324
1.98	Tx screw driver ..... 325
1.99	Summary: Tools for cross bushings and anchors ..... 326
1.99	Drill Jigs ..... 327, 329
1.99	Milling cutters ..... 328, 330
1.99	Drills ..... 328, 330
1.99	Tools: Special cases ..... 331
1.99	Screw taps ..... 332
<b>1.A</b>	<b>CAD-Library ..... 334</b>
1.A1	MayTec Online Library ..... 334
1.A2	MayTec 3D Library with B&W Profiles ..... 335
<b>1.B</b>	<b>Conversion tables ..... 336</b>
1.B1	Metric and English Conversion Table ..... 336
1.B2	Metric / U.S. Customary Unit ..... 337
	<b>Subject index ..... 338</b>

## General

### Profile group

**16 mm, 20 mm, 30 mm, 40 mm, 45 mm, 50 mm, 60 mm**

The profiles of the MayTec Profile System are divided into seven **profile groups (PG)**. They can be determined by the basic measure of each profile.

### Slot

#### H-slot, F-slot, E-slot

In order to connect the profiles or to mount accessories the profiles have slots. The MayTec Slot System (→ 1.02) distinguishes between the three slot types H-slot, F-slot and E-slot, whereas E-slot exists as **E3-slot** and **E4-slot** (3 or 4 mm wall thickness).

## Symbols

Many articles (fastening elements, accessories and tools) can only be used especially for individual profile groups or slot types.

In this case these articles are marked with the corresponding symbols.



#### Profile group

dark symbol: suitable for the corresponding profile group

light symbol: not suitable

#### Slot type

dark symbol: suitable for the corresponding slot type

light symbol: not suitable

#### Remark

The symbol for the E-slot is used, if the article is (un)suitable for the two slot types E3 and E4.



#### Cut

These articles are offered with cut.



#### Stainless steel

These articles are made of stainless steel.



#### Cleanroom

These articles are suitable for the use in and around cleanrooms.



#### Attention!

Important notice















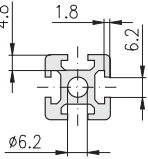

## Abbreviations

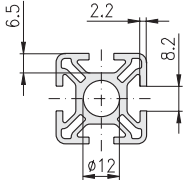
PG	<b>profile group</b>	e.g.: PG 30 = profile group 30 mm
L	<b>light</b>	profile characteristic: light type of construction
S	<b>heavy</b>	profile characteristic: heavy type of construction
P	<b>plain</b>	profile characteristic: no ornamental slots

## Special characters

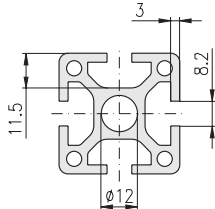
<input type="checkbox"/>	<b>Placeholder</b> Article-No.	<b>Example</b> 1.41.5□□.□	<b>identifies the articles:</b> 1.41.5F0.1 1.41.5F0.2 1.41.5E0.1 1.41.5E0.2
--------------------------	-----------------------------------	------------------------------	---

	<b>Example</b> 117 1.41 1.41.710.2 1.41.5□□.□	<b>Reference</b> <i>to catalogue page</i> <i>to article number group</i> <i>to single article</i> <i>to group of articles</i>
---	---	---

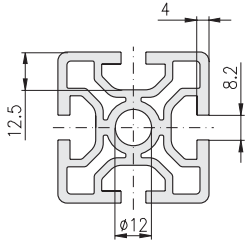
Cross section of slots		Core hole-Ø	Slot width	Slot depth	Wall thickness	PG		
<b>H-slot</b>     		6.2	6.2	4.8	1.8	20		
<b>F-slot</b>     		12.0	8.2	6.5	2.2	20		
								30
<b>E3-slot</b>     		12.0	8.2	11.5	3.0	40		
<b>E4-slot</b>     		12.0	8.2	12.5	4.0	45		
								50
								60





**Profiles**

1.1 □ . □□□□□□ . □□□□□  
 1.1 □ . □□□□□□ . □□□□□  
 1.1 □ . □□□□□□ . □□□□□  
 1.1 □ . □□□ R □□ . □□□□□  
 1.1 □ . □□□ k t . □□□□□  
 1.1 □ . □□□□□□ . □□□□□  
 1.1 □ . □□□□□□ . □□□□□  
 1.1 □ . □□□□□□ . □□ L  
 1.1 □ . □□□□□□ . □□ B  
 1.1 □ . □□□□□□ . □□ L B  
 1.1 □ . □□□□□□ . □□ P

**Key**  
 Core hole-Ø <sup>1)</sup>  
 Profile width  
 Profile height (all, but special profiles)  
 Number of degrees (round profiles)  
 Number of edges (special profiles)  
 Slot quantity <sup>2)</sup>  
 Contour <sup>3)</sup>  
 Version light  
 Type B  
 Version light, Type B  
 Plain

<sup>1)</sup> 0 = 6.2 mm  
 1 = 12 mm  
<sup>2)</sup> 2-digit off 10 slots  
<sup>3)</sup> 0 = Round  
 1 = Soft  
 2 = Corner  
 3 = Cubic  
 4 = Rectangle  
 5 = Pneumatic  
 7 = Angle  
 8 = Angle 45°  
 9 = Special

**Connectors  
 - general**

1.2 □ . □□□□□  
 1.2 □ . □□□□□  
 1.2 □ . □□□□□  
 1.2 □ . □□□□□  
 1.2 □ . □□□□□  
 1.2 □ . □□□ V □  
 1.2 □ . □□□□ E  
 □/□  
 □/□  
 □/□

**Special cases:** Parallel-connector across and high  
 Profile width for cross bushing  
 Profile width for anchor

**Key**  
 Core hole <sup>1)</sup>  
 Profile width <sup>2)</sup>  
 Head-variant <sup>3)</sup>  
 Connection-variant <sup>4)</sup>  
 Stainless  
 Ground

<sup>1)</sup> 0 = 6.2 mm  
 1 = 12 mm  
<sup>2)</sup> 2 = 20 mm  
 3 = 30 mm  
 4 = 40 mm  
 45 = 45 mm  
 5 = 50 mm  
 6 = 60 mm  
<sup>3)</sup> E = E-head  
 F = F-head  
 H = H-head  
 V = Extension  
<sup>4)</sup> 0 = Universal/Neutral  
 1 = Standard  
 2 = Standard 90°  
 4 = Square head  
 5 = Parallel

**-Oblique-hinge**

1.2 □ . □□□□□  
 1.2 □ . □□□ K □□  
 1.2 □ . □□□□□  
 1.2 □ . □□□□ V

**Key**  
 Oblique-connector, hinge  
 Connection-variant <sup>1)</sup>  
 Stainless

<sup>1)</sup> 1 = Standard  
 2 = Standard 90°

**-Oblique-bent anchor**

1.2 □ . □□□□□ / □□□□□  
 1.2 □ . □□□ B □□ / □□□□□  
 1.2 □ . □□□□□ / □□□□□  
 1.2 □ . □□□□□ / □□□□□  
 1.2 □ . □□□□□ / □□□□□  
 1.2 □ . □□□□□ / □□ V □  
 1.2 □ . □□□□□ / □□□□ E

**Key**  
 Oblique-connector, bent anchor  
 Connection-variant <sup>1)</sup>  
 Design L/R  
 Angle  
 Stainless  
 Ground

<sup>1)</sup> 1 = Standard  
 2 = Standard 90°

**-Miter-hinge**

1.2 □ . □□□□□  
 1.2 □ . □□ G □□  
 1.2 □ . □□□□□  
 1.2 □ . □□□□ V

**Key**  
 Miter-connector, hinge  
 Connection-variant <sup>1)</sup>  
 Stainless

<sup>1)</sup> 1 = Standard  
 2 = Standard 90°

**-Miter-bent anchor**

1.2 □ . □□□□□ / □□□□□  
 1.2 □ . □□ G □□ / □□□□□  
 1.2 □ . □□□ B □□ / □□□□□  
 1.2 □ . □□□□□ / □□□□□  
 1.2 □ . □□□□□ / □□□□□  
 1.2 □ . □□□□□ / □□□□ V

**Key**  
 Miter-connector  
 Bent design  
 Connection-variant <sup>1)</sup>  
 Angle  
 Stainless

<sup>1)</sup> 1 = Standard  
 2 = Standard 90°

**-Screw-type**

1.2 □ . □□□□□ / □□□□□  
 1.2 □ . □□ S □□□ / □□□□□  
 1.2 □ . □□□□□ / □□□□□  
 1.2 □ . □□□□ M □ / □□□□□  
 1.2 □ . □□□□□ / □□□□□  
 1.2 □ . □□□□□ / □□□□□  
 □/□  
 □/□  
 □/□

**Special cases:** Screw-type connector parallel across and high  
 Profile width for cross bushing  
 Profile width for anchor

**Key**  
 Screw-type-connector  
 Type of anchor <sup>1)</sup>  
 Thread  
 Thread-Ø  
 Screw special length

<sup>1)</sup> 1 = Standard  
 2 = Parallel 20 mm  
 3 = Parallel 30 mm  
 4 = Parallel 40 mm  
 5 = Parallel 50 mm

**16**  
plain

**F** 16x40

L

S

1F LP

1F P

**E** 16x40 16x80

L

S

1E LP

2E LP

4E LP

1E P

2E P

16x160

16x40 16x80

**20**  
plain

**H** 20x20 20x40 40x40

L

S

2H LP

4H LP

2H s. P

2H c. P

3H P

4H P

4H P

6H LP

8H LP

6H P

**F** 20x10 20x30 20x30

L

S

1F LP

1F LP

2F LP

2F P

**30**  
plain

**F** 30x30 30x60 30x100 30x150 60x60

L

S

1F LP

2F c. LP

2F LP

3F LP

4F LP

2F s. P

0F P

1F P

2F c. BP

2F P

3F P

4F P

0F P

6F LP

6F P

8F P

9F P

10F P

8F P

0F P

**F** 30x100

**E3**

**E4**

5E 2F P

**40**  
plain

**E3** 40x40 40x60 40x80 40x160 80x80

L

S

2E s. LP

0E LP

1E LP

2E c. LP

2E LP

3E LP

4E LP

0E LP

0E LP

3E c. LP

4E LP

4E LBP

5E LP

6E LP

6E LP

0E LP

4E c. LP

6E LP

8E LP

40 r.45°

40 r.90°

2E LP

2E LP

2E 45° LP

3E 45° LP

7E 45° LP

4E P

6E P

7E BP

7E P

8E P

**45**  
plain

**E4** 45x45 45x60 45x90 90x90

L

S

2E s. LP

0E LP

1E LP

2E c. LP

2E LP

3E LP

4E LP

4E LP

0E LP

6E LP

8E LP

4E P

4E P

0E P

6E P

8E P

**50**  
plain

**E4**

L

S

**60**  
plain

**E4** 60x60

L

S

2E LP

4E LP

2E P

4E P

plain

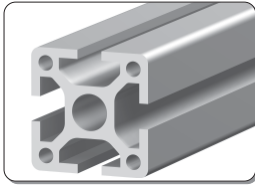

without grooves

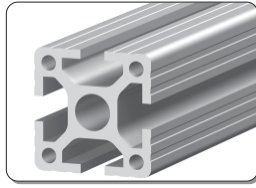

with grooves

16	20	30	40	45	50	60	Profile group
S							Special profiles
H F E							Slot type
plain							plain

L	light
S	heavy
P	plain
B	type B
hexag.	hexagonal

octag.	octagonal
c.	corner
r.	round
s.	soft
angle	angle

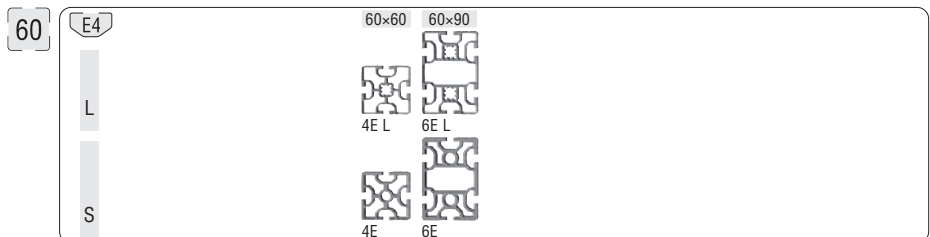
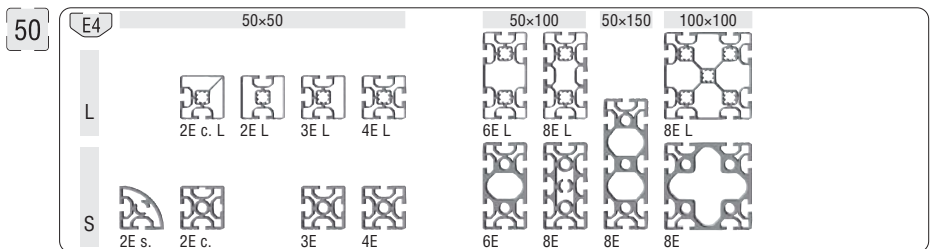
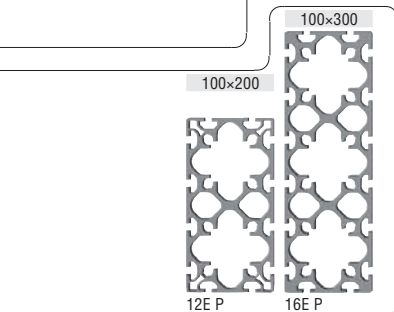
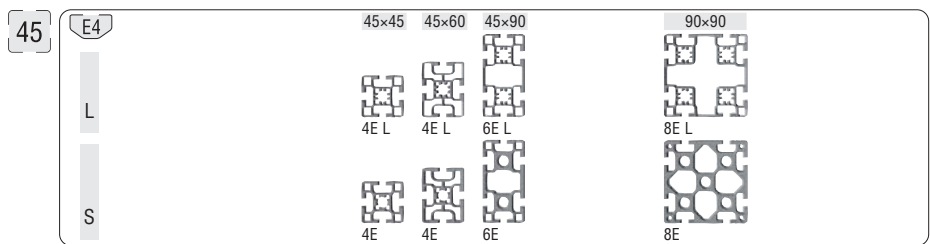
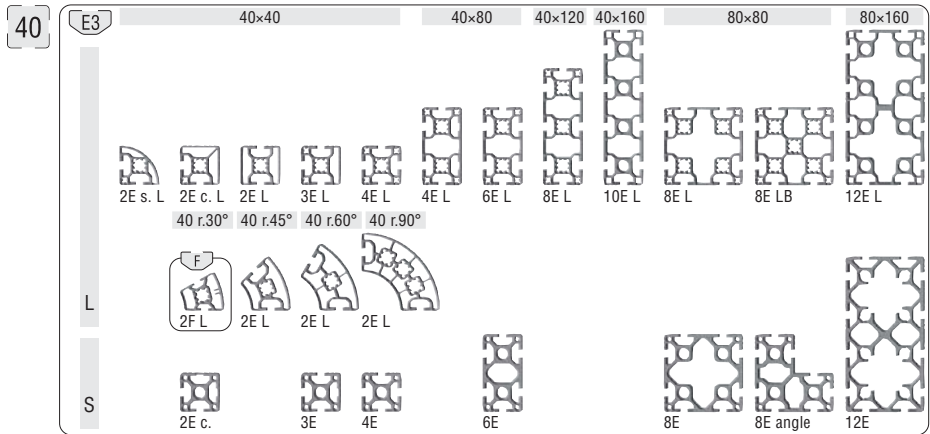
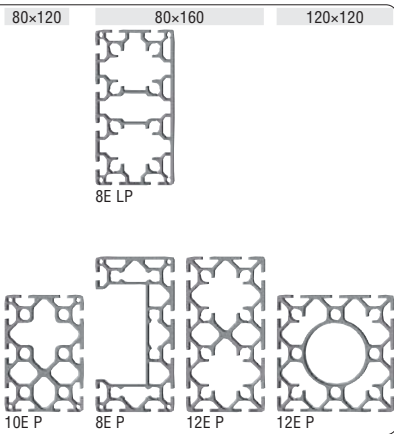
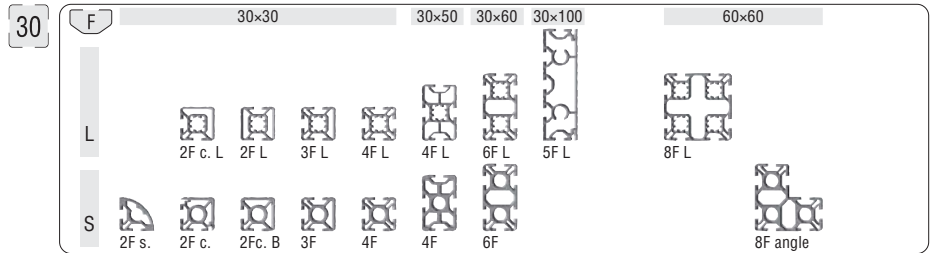
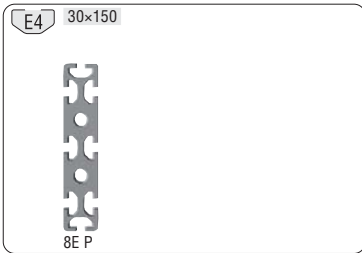

**S**

**Safety barrier profiles**

Wire net profiles      Panel profiles

**30**  
plain

F 30x30 30x45

L 2F LP 2F LP

S

**40**  
plain

E3 40x40 40x60

L 2E LP 2E LP

L

40x40 40x60

2E c. LP 3E LP 3E LP

60x80

5E LP 6E LP

**Available only in USA!**

**Inch profiles**

**1**  
plain

F 1"x1" 2"x2"

L 4F P 8F P

S

**1.5**  
plain

E 1.5"x1.5" 1.5"x3" 3"x3" 3"x6"

L 4E LP 6E LP

S 4E P 6E P 8E P 12E P

**S**

**E-trunking profiles**

plain

Lid 40 40x20 40x20 40x40 40x80 80x40 200x50

Lid 80 80x40

Lid 200 200x50

Profile pre-cut lid 120 80x160 8E P

**S**

**Profiles hexagonal**

plain

**Round**      **hexagonal**      **octagonal**

48 round      30 hexag.      40 hexag.      30 octag.      40 octag.

1E P 2E c. P 2E P 6F P 6E P 8F P 8E P

**S**

**Roller profiles**

plain

60/31 63/31 100/53 105/53

**S**

**Carriage support profiles**

**40**  
plain

F 80x120 80x180

E3

L 4E 2F P 4E 2F P

S

**S**

**Telescopic profiles**

**40**  
plain

E3 40x40 80x80 120x120 160x160

L 8E P 8E BP 12E P 16E P

S

<p><b>Profile pre-cut lids</b></p> <p>50 Profile pre-cut lid 30 Profile pre-cut lid 40 Profile pre-cut lid 50 Profile pre-cut lid 120</p>	<p><b>Tubes</b></p> <p>53 Tube Ø20x2 Tube Ø30x3 Tube Ø40x4</p>
<p><b>Hollow profiles</b></p> <p>50 Hollow profile Ø20 Hollow profile Ø30 Hollow profile Ø40</p>	<p><b>Hinge profiles</b> 1.5 mm</p> <p>53 Type A, PG 20 - 1.5 Type A, PG 30 - 1.5 Type A, PG 40 - 1.5 Type A, PG 50 - 1.5</p>
<p><b>Base profiles</b></p> <p>50 Base profile Ø20 Base profile Ø30 Base profile Ø40</p>	<p><b>Hinge profiles</b> 2.0 mm / 5.0 mm</p> <p>53 Type B, 40 mm - 2.0 Type B, 50 mm - 2.0 Type C, 30 mm - 2.0 Ø12 5.0</p>
<p><b>Angle profiles</b></p> <p>51 Angle profile 48x48 Angle profile 60x60 Angle profile 100x100</p>	<p><b>Hinge profiles</b> 3.0 mm</p> <p>54 Type A, PG 30 - 3.0 Type A, PG 40 - 3.0 Type A, PG 50 - 3.0 Type B, 50 mm - 3.0</p>
<p><b>Wire net mounting profiles</b></p> <p>51 Wire net mounting profile Wire net mounting profile 33x10</p>	<p><b>T-Slot profiles</b> Steel</p> <p>54 T-Slot profile, steel, F T-Slot profile, steel, E T-Slot profile, steel, subs. ins. F T-Slot profile, steel, subs. ins. E</p>
<p><b>Grab handle profiles</b></p> <p>51 Grab handle profile Grab handle profile</p>	<p><b>T-Slot profiles</b> PA</p> <p>54 T-Slot profile, PA, F T-Slot profile, PA, E</p>
<p><b>U-profiles, C-track</b></p> <p>52 U-profile 25x25x2 U-profile 40 C-track</p>	<p><b>Slide-slot profiles</b> PA</p> <p>55 Slide-slot profile, PA, F Slide-slot profile, PA, E3 Slide-slot profile, PA, E4</p>
<p><b>Sliding profiles</b></p> <p>52 Sliding profile 30x14 Sliding profile 30x26 Sliding profile 33x14 Sliding profile 33x26</p>	<p><b>Slide-slot profiles</b> PA</p> <p>55 Slide-slot profile, PA, F/E3 Slide-slot profile, PA, F/E4 Slide-slot profile, PA, E3/E4</p>
<p><b>Sliding profile, Panel framing profile</b></p> <p>52 Sliding profile 50x14 Panel framing profile 30x8,5</p>	<p><b>19" profiles</b></p> <p>55 19" profile, PG 30 19" profile, PG 40 19" profile, PG 50</p>











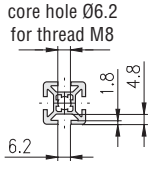

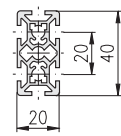

light				
Description	Profile 16×40, 1F, LP	Profile 16×40, 1E, LP	Profile 16×80, 2E, LP	Profile 16×160, 4E, LP
bar, 6 m	1.10.016040.14LP.60	1.09.016040.14LP.60	1.09.016080.24LP.60	1.09.016160.44LP.60
packing unit (number)	1.10.016040.14LP.61 (20)	1.09.016040.14LP.61 (20)	1.09.016080.24LP.61 (10)	1.09.016160.44LP.61 (5)
moment of inertia cm <sup>4</sup>	$I_x = 4.4$ $I_y = 0.8$	$I_x = 4.3$ $I_y = 0.8$	$I_x = 30.7$ $I_y = 1.6$	$I_x = 238.3$ $I_y = 3.3$
moment of resistance cm <sup>3</sup>	$W_x = 2.2$ $W_y = 0.8$	$W_x = 2.2$ $W_y = 0.8$	$W_x = 7.7$ $W_y = 1.6$	$W_x = 29.8$ $W_y = 3.3$
weight kg/m	$G = 0.87$	$G = 0.75$	$G = 1.49$	$G = 3.0$

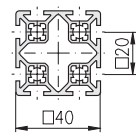
heavy				
Description	Profile 16×40, 1F, P	Profile 16×40, 1E, P	Profile 16×80, 2E, P	
bar, 6 m	1.10.016040.14P.60	1.09.016040.14P.60	1.09.016080.24P.60	
packing unit (number)	1.10.016040.14P.61 (20)	1.09.016040.14P.61 (20)	1.09.016080.24P.61 (10)	
moment of inertia cm <sup>4</sup>	$I_x = 5.3$ $I_y = 1.0$	$I_x = 7.2$ $I_y = 1.1$	$I_x = 48.3$ $I_y = 2.2$	
moment of resistance cm <sup>3</sup>	$W_x = 2.7$ $W_y = 1.0$	$W_x = 3.6$ $W_y = 1.1$	$W_x = 12.0$ $W_y = 2.2$	
weight kg/m	$G = 1.0$	$G = 1.14$	$G = 2.11$	

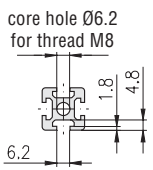
light				
<p>core hole Ø6.2 for thread M8</p>				
Description			Profile 20×20, 2H, LP	
bar, 6 m			1.10.020020.23LP.60	
packing unit (number)			1.10.020020.23LP.61 (10)	
moment of inertia cm <sup>4</sup>			$I_x = 1.0$	$I_y = 0.8$
moment of resistance cm <sup>3</sup>			$W_x = 1.0$	$W_y = 0.8$
weight kg/m			$G = 0.58$	

heavy				
<p>core hole Ø6.2 for thread M8</p>				
Description	Profile 20×20, 2H, soft, P	Profile 20×20, 2H, cor., P		Profile 20×20, 3H, P
bar, 6 m	1.10.020020.21P.60	1.10.020020.22P.60		1.10.020020.33P.60
packing unit (number)	1.10.020020.21P.61 (10)	1.10.020020.22P.61 (10)		1.10.020020.33P.61 (10)
moment of inertia cm <sup>4</sup>	$I_x = 0.6$	$I_x = 1.0$		$I_x = 0.9$
moment of resistance cm <sup>3</sup>	$W_x = 0.6$	$W_x = 0.9$		$W_x = 0.9$
weight kg/m	$G = 0.52$	$G = 0.68$		$G = 0.65$

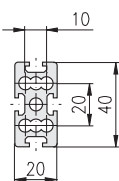

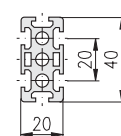
light				
	  		  	  
Description	Profile 20×20, 4H, LP		Profile 20×40, 6H, LP	Profile 40×40, 8H, LP
bar, 6 m	1.10.020020.43LP.60		1.10.020040.64LP.60	1.10.040040.83LP.60
packing unit (number)	1.10.020020.43LP.61 (10)		1.10.020040.64LP.61 (10)	1.10.040040.83LP.61 (10)
moment of inertia cm <sup>4</sup>	$I_x = 0.8$ $I_y = 0.8$		$I_x = 5.3$ $I_y = 1.4$	$I_x = 10.0$ $I_y = 10.0$
moment of resistance cm <sup>3</sup>	$W_x = 0.8$ $W_y = 0.8$		$W_x = 2.6$ $W_y = 1.4$	$W_x = 5.0$ $W_y = 5.0$
weight kg/m	$G = 0.53$		$G = 0.9$	$G = 1.5$





heavy				
	  	  	  	
Description	Profile 20×20, 4H, P	Profile 20×40, 4H, P	Profile 20×40, 6H, P	
bar, 6 m	1.10.020020.43P.60	1.10.020040.44P.60	1.10.020040.64P.60	
packing unit (number)	1.10.020020.43P.61 (10)	1.10.020040.44P.61 (10)	1.10.020040.64P.61 (10)	
moment of inertia cm <sup>4</sup>	$I_x = 0.9$ $I_y = 0.9$	$I_x = 7.0$ $I_y = 2.0$	$I_x = 6.4$ $I_y = 1.7$	
moment of resistance cm <sup>3</sup>	$W_x = 0.9$ $W_y = 0.9$	$W_x = 3.5$ $W_y = 2.0$	$W_x = 3.2$ $W_y = 1.7$	
weight kg/m	$G = 0.62$	$G = 1.3$	$G = 1.3$	

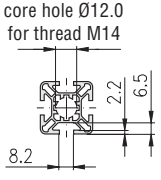

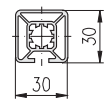
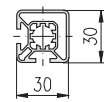

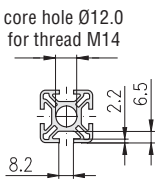



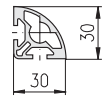
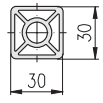
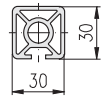
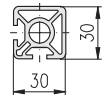





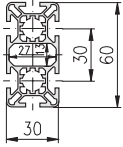

light				
Description	Profile 20×10, 1F, LP	Profile 20×30, 1F, LP	Profile 20×30, 2F, LP	
bar, 6 m	1.11.020010.14LP.60	1.11.020030.14LP.60	1.11.020030.24LP.60	
packing unit (number)	1.11.020010.14LP.61 (10)	1.11.020030.14LP.61 (10)	1.11.020030.24LP.61 (10)	
moment of inertia cm <sup>4</sup>	$I_x = 0.1$	$I_x = 2.2$	$I_x = 2.2$	$I_y = 0.6$
moment of resistance cm <sup>3</sup>	$W_x = 0.2$	$W_x = 1.5$	$W_x = 1.5$	$W_y = 0.5$
weight kg/m	$G = 0.35$	$G = 0.7$	$G = 0.74$	

heavy				
Description			Profile 20×30, 2F, P	
bar, 6 m			1.11.020030.24P.60	
packing unit (number)			1.11.020030.24P.61 (10)	
moment of inertia cm <sup>4</sup>			$I_x = 2.6$	$I_y = 1.9$
moment of resistance cm <sup>3</sup>			$W_x = 1.7$	$W_y = 1.7$
weight kg/m			$G = 1.0$	

light				
				
				
Description			Profile 30×30, 1F, LP	Profile 30×30, 2F, cor., LP
bar, 6 m			1.11.030030.13LP.60	1.11.030030.22LP.60
packing unit (number)			1.11.030030.13LP.61 (10)	1.11.030030.22LP.61 (10)
moment of inertia cm <sup>4</sup>			$I_x = 3.1$	$I_x = 3.2$
moment of resistance cm <sup>3</sup>			$W_x = 2.1$	$W_x = 2.1$
weight kg/m			$G = 0.9$	$G = 0.9$

heavy				
				
				
Description	Profile 30×30, 2F, soft, P	Profile 30×30, 0F, P	Profile 30×30, 1F, P	Profile 30×30, 2F, cor., BP
bar, 6 m	1.11.030030.21P.60	1.11.030030.03P.60	1.11.030030.13P.60	1.11.030030.22BP.60
packing unit (number)	1.11.030030.21P.61 (10)	1.11.030030.03P.61 (10)	1.11.030030.13P.61 (10)	1.11.030030.22BP.61 (10)
moment of inertia cm <sup>4</sup>	$I_x = 2.7$	$I_x = 4.4$	$I_x = 4.3$	$I_x = 3.7$
moment of resistance cm <sup>3</sup>	$W_x = 1.6$	$W_x = 2.3$	$W_x = 2.9$	$W_x = 2.4$
weight kg/m	$G = 0.9$	$G = 1.3$	$G = 1.2$	$G = 1.1$

				
				
Profile 30×30, 2F, LP	Profile 30×30, 3F, LP	Profile 30×30, 4F, LP		Profile 30×60, 6F, LP
1.11.030030.23LP.60	1.11.030030.33LP.60	1.11.030030.43LP.60		1.11.030060.64LP.60
1.11.030030.23LP.61 (10)	1.11.030030.33LP.61 (10)	1.11.030030.43LP.61 (10)		1.11.030060.64LP.61 (6)
$I_x = 3.2$ $I_y = 3.2$ $W_x = 2.1$ $W_y = 2.1$ $G = 0.9$	$I_x = 3.3$ $I_y = 3.2$ $W_x = 2.2$ $W_y = 2.2$ $G = 0.9$	$I_x = 3.3$ $I_y = 3.3$ $W_x = 2.2$ $W_y = 2.2$ $G = 0.9$		$I_x = 21.2$ $I_y = 5.7$ $W_x = 7.0$ $W_y = 3.8$ $G = 1.6$

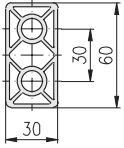
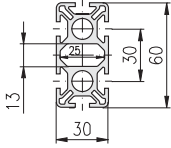



				
				
Profile 30×30, 2F, P	Profile 30×30, 3F, P	Profile 30×30, 4F, P	Profile 30×60, 0F, P	Profile 30×60, 6F, P
1.11.030030.23P.60	1.11.030030.33P.60	1.11.030030.43P.60	1.11.030060.04P.60	1.11.030060.65P.60
1.11.030030.23P.61 (10)	1.11.030030.33P.61 (10)	1.11.030030.43P.61 (10)	1.11.030060.04P.61 (6)	1.11.030060.65P.61 (6)
$I_x = 3.6$ $I_y = 3.9$ $W_x = 2.4$ $W_y = 2.6$ $G = 1.1$	$I_x = 3.5$ $I_y = 3.7$ $W_x = 2.4$ $W_y = 2.4$ $G = 1.1$	$I_x = 3.5$ $I_y = 3.5$ $W_x = 2.4$ $W_y = 2.4$ $G = 1.1$	$I_x = 29.0$ $I_y = 7.8$ $W_x = 9.6$ $W_y = 5.2$ $G = 2.2$	$I_x = 25.0$ $I_y = 7.0$ $W_x = 8.3$ $W_y = 4.7$ $G = 2.1$

light				
Description				
bar, 6 m				
packing unit (number)				
moment of inertia $\text{cm}^4$				
moment of resistance $\text{cm}^3$				
weight $\text{kg/m}$				



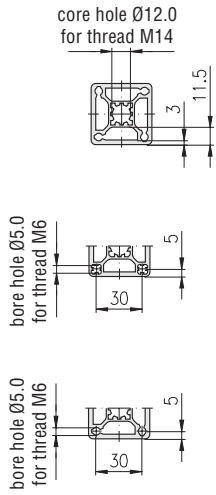

heavy			
<p>core hole <math>\text{Ø}12.0</math> for thread M14</p>			
Description	Profile 30×100, 5E, 2F, P	Profile 30×100, 8F, P	Profile 30×100, 9F, P
bar, 6 m	1.11.030100.74P.60	1.11.030100.84P.60	1.11.030100.94P.60
packing unit (number)	1.11.030100.74P.61 (4)	1.11.030100.84P.61 (4)	1.11.030100.94P.61 (4)
moment of inertia $\text{cm}^4$	$I_x = 108.9$ $I_y = 12.4$	$I_x = 115.0$ $I_y = 11.6$	$I_x = 130.6$ $I_y = 11.9$
moment of resistance $\text{cm}^3$	$W_x = 21.7$ $W_y = 8.3$	$W_x = 22.9$ $W_y = 7.7$	$W_x = 25.9$ $W_y = 7.9$
weight $\text{kg/m}$	$G = 3.5$	$G = 3.4$	$G = 3.6$

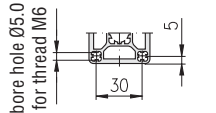
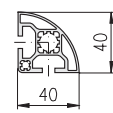
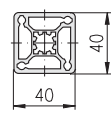
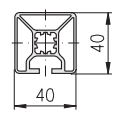
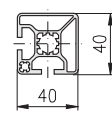
machining data Profile machining 1.1A

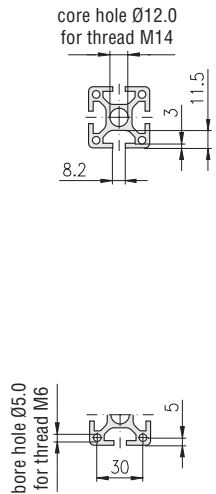
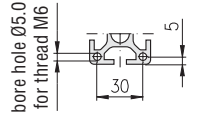





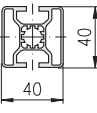
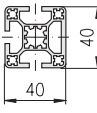
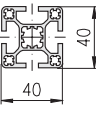
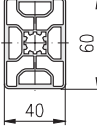
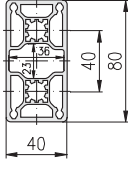

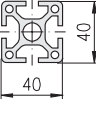

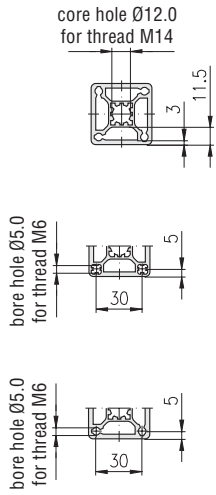
			<p>Connection possibilities</p> <ul style="list-style-type: none"> <li>➤ 106, Universal connector</li> <li>➤ 110, ST-Connector</li> </ul>
<p>Profile 30×100, 10F, P</p>	<p>Profile 30×150, 8F, P</p>	<p>Profile 30×150, 8E, P</p>	<p>Profile 60×60, 0F, P</p>
<p>1.11.030100.104P.60</p>	<p>1.11.030150.85P.60</p>	<p>1.11.030150.84P.60</p>	<p>1.11.060060.03P.60</p>
<p>1.11.030100.104P.61 (4)</p>	<p>1.11.030150.85P.61 (2)</p>	<p>1.11.030150.84P.61 (2)</p>	<p>1.11.060060.03P.61 (6)</p>
<p><math>I_x = 127.0</math> <math>I_y = 11.9</math>  <math>W_x = 25.4</math> <math>W_y = 7.9</math>  <math>G = 3.6</math></p>	<p><math>I_x = 340.0</math> <math>I_y = 16.0</math>  <math>W_x = 45.0</math> <math>W_y = 11.0</math>  <math>G = 4.1</math></p>	<p><math>I_x = 481.0</math> <math>I_y = 25.1</math>  <math>W_x = 64.1</math> <math>W_y = 16.7</math>  <math>G = 7.9</math></p>	<p><math>I_x = 58.2</math> <math>I_y = 58.2</math>  <math>W_x = 15.5</math> <math>W_y = 15.5</math>  <math>G = 4.0</math></p>

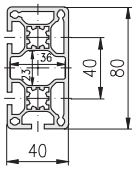
light					
					
					
Description		Profile 40x40, 2E, soft, LP	Profile 40x40, 0E, LP	Profile 40x40, 1E, LP	Profile 40x40, 2E, cor., LP
bar, 6 m		1.11.040040.21LP.60	1.11.040040.03LP.60	1.11.040040.13LP.60	1.11.040040.22LP.60
packing unit (number)		1.11.040040.21LP.61 (8)	1.11.040040.03LP.61 (8)	1.11.040040.13LP.61 (8)	1.11.040040.22LP.61 (8)
moment of inertia cm <sup>4</sup>		$I_x = 6.4$ $I_y = 6.4$	$I_x = 12.0$ $I_y = 12.0$	$I_x = 8.5$ $I_y = 8.1$	$I_x = 8.0$ $I_y = 8.0$
moment of resistance cm <sup>3</sup>		$W_x = 3.8$ $W_y = 3.8$	$W_x = 6.0$ $W_y = 6.0$	$W_x = 4.1$ $W_y = 4.0$	$W_x = 4.0$ $W_y = 4.0$
weight kg/m		G = 1.2	G = 1.8	G = 1.3	G = 1.3

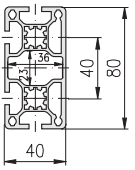
heavy					
					
					
Description					
bar, 6 m					
packing unit (number)					
moment of inertia cm <sup>4</sup>					
moment of resistance cm <sup>3</sup>					
weight kg/m					

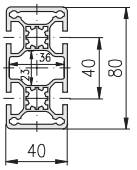

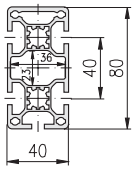
				
				
Profile 40×40, 2E, LP	Profile 40×40, 3E, LP	Profile 40×40, 4E, LP	Profile 40×60, 0E, LP	Profile 40×80, 0E, LP
1.11.040040.23LP.60	1.11.040040.33LP.60	1.11.040040.43LP.60	1.11.040060.04LP.60	1.11.040080.04LP.60
1.11.040040.23LP.61 (8)	1.11.040040.33LP.61 (8)	1.11.040040.43LP.61 (8)	1.11.040060.04LP.61 (8)	1.11.040080.04LP.61 (4)
$I_x = 8.2$ $I_y = 7.5$ $W_x = 4.1$ $W_y = 3.8$ $G = 1.3$	$I_x = 9.4$ $I_y = 10.0$ $W_x = 4.7$ $W_y = 5.0$ $G = 1.5$	$I_x = 9.9$ $I_y = 9.9$ $W_x = 4.9$ $W_y = 4.9$ $G = 1.5$	$I_x = 27.7$ $I_y = 13.1$ $W_x = 9.3$ $W_y = 6.5$ $G = 2.1$	$I_x = 79.0$ $I_y = 21.5$ $W_x = 19.7$ $W_y = 10.7$ $G = 3.1$

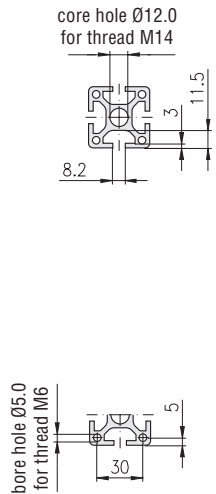

				
				
		Profile 40×40, 4E, P		
		1.11.040040.43P.60		
		1.11.040040.43P.61 (8)		
		$I_x = 12.0$ $I_y = 12.0$ $W_x = 6.0$ $W_y = 6.0$ $G = 2.0$		

light					
		 	 	 	 
Description		Profile 40x80, 3E, cor., LP	Profile 40x80, 4E, LP	Profile 40x80, 4E, LBP	Profile 40x80, 5E, LP
bar, 6 m		1.11.040080.32LP.60	1.11.040080.44LP.60	1.11.040080.44LBP.60	1.11.040080.54LP.60
packing unit (number)		1.11.040080.32LP.61 (4)	1.11.040080.44LP.61 (4)	1.11.040080.44LBP.61 (4)	1.11.040080.54LP.61 (4)
moment of inertia	cm <sup>4</sup>	$I_x = 73.8$ $I_y = 20.5$	$I_x = 70.7$ $I_y = 20.0$	$I_x = 74.5$ $I_y = 18.3$	$I_x = 72.2$ $I_y = 18.1$
moment of resistance	cm <sup>3</sup>	$W_x = 18.5$ $W_y = 10.2$	$W_x = 17.7$ $W_y = 8.9$	$W_x = 18.6$ $W_y = 9.2$	$W_x = 18.0$ $W_y = 9.0$
weight	kg/m	G = 2.8	G = 2.8	G = 2.8	G = 2.8

heavy					
					
Description					
bar, 6 m					
packing unit (number)					
moment of inertia	cm <sup>4</sup>				
moment of resistance	cm <sup>3</sup>				
weight	kg/m				

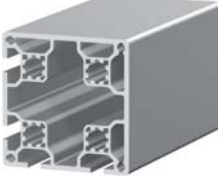
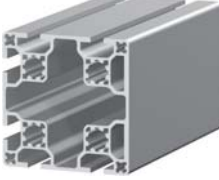
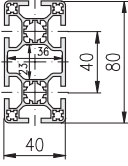
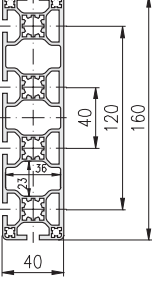
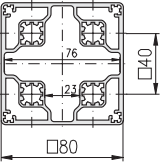
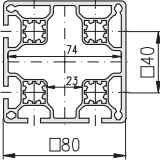
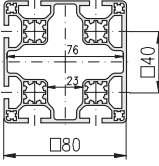

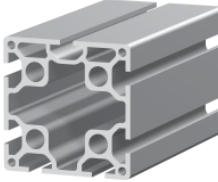
				
				
Profile 40x80, 6E, LP	Profile 40x160, 6E, LP	Profile 80x80, 0E, LP	Profile 80x80, 4E, cor., LP	Profile 80x80, 6E, LP
1.11.040080.64LP.60	1.11.040160.64LP.60	1.11.080080.03LP.60	1.11.080080.42LP.60	1.11.080080.63LP.60
1.11.040080.64LP.61 (4)	1.11.040160.64LP.61 (2)	1.11.080080.03LP.61 (2)	1.11.080080.42LP.61 (2)	1.11.080080.63LP.61 (2)
$I_x = 62.7$ $I_y = 17.7$ $W_x = 15.6$ $W_y = 8.8$ $G = 2.5$	$I_x = 450.4$ $I_y = 36.3$ $W_x = 56.3$ $W_y = 18.1$ $G = 5.0$	$I_x = 135.0$ $I_y = 135.0$ $W_x = 33.5$ $W_y = 33.5$ $G = 4.7$	$I_x = 128.0$ $I_y = 128.0$ $W_x = 32.0$ $W_y = 32.0$ $G = 4.5$	$I_x = 121.3$ $I_y = 116.0$ $W_x = 30.3$ $W_y = 29.0$ $G = 4.2$

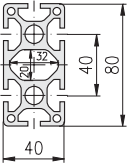
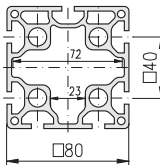
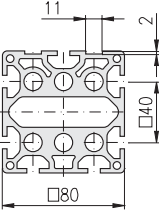
				
				
Profile 40x80, 6E, P			Profile 80x80, 7E, BP	Profile 80x80, 7E, P
1.11.040080.64P.60			1.11.080080.73BP.60	1.11.080080.79P.60
1.11.040080.64P.61 (4)			1.11.080080.73BP.61 (2)	1.11.080080.79P.61 (2)
$I_x = 82.0$ $I_y = 23.4$ $W_x = 20.5$ $W_y = 11.7$ $G = 3.8$			$I_x = 145.0$ $I_y = 141.0$ $W_x = 36.2$ $W_y = 35.2$ $G = 5.3$	$I_x = 173.0$ $I_y = 160.0$ $W_x = 43.3$ $W_y = 40.0$ $G = 7.6$

light				
<p>core hole Ø12.0 for thread M14</p> <p>bore hole Ø5.0 for thread M6</p> <p>bore hole Ø5.0 for thread M6</p>	 	 		
Description	Profile 80×80, 8E, LP		Profile 80×160, 8E, LP	
bar, 6 m	1.11.080080.83LP.60		1.11.080160.84LP.60	
packing unit (number)	1.11.080080.83LP.61 (2)		1.11.080160.84LP.61 (2)	
moment of inertia cm <sup>4</sup>	$I_x = 114.0$ $I_y = 114.0$		$I_x = 828.0$ $I_y = 259.0$	
moment of resistance cm <sup>3</sup>	$W_x = 28.4$ $W_y = 28.4$		$W_x = 104.0$ $W_y = 65.0$	
weight kg/m	$G = 4.1$		$G = 8.6$	

heavy				
<p>core hole Ø12.0 for thread M14</p> <p>bore hole Ø5.0 for thread M6</p>	 	 	 	Application ↗ E-trunking profiles, 57, 311-313
Description	Profile 80×80, 8E, P	Profile 80×120, 10E, P	Profile 80×160, 12E, P	
bar, 6 m	1.11.080080.83P.60	1.11.080120.104P.60	1.11.080160.89P.60	
packing unit (number)	1.11.080080.83P.61 (2)	1.11.080120.104P.61 (2)	1.11.080160.89P.61 (2)	
moment of inertia cm <sup>4</sup>	$I_x = 166.0$ $I_y = 166.0$	$I_x = 449.9$ $I_y = 217.8$	$I_x = 944.0$ $I_y = 183.0$	
moment of resistance cm <sup>3</sup>	$W_x = 41.4$ $W_y = 41.4$	$W_x = 72.6$ $W_y = 54.4$	$W_x = 118.0$ $W_y = 45.8$	
weight kg/m	$G = 5.9$	$G = 8.6$	$G = 7.9$	

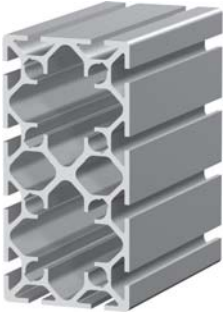
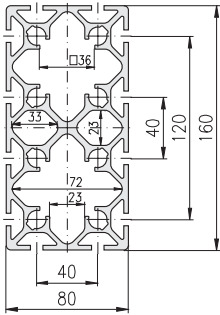
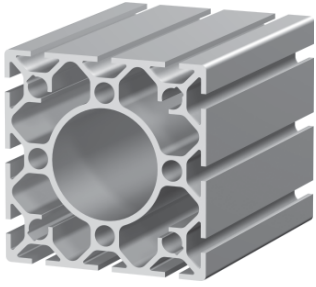
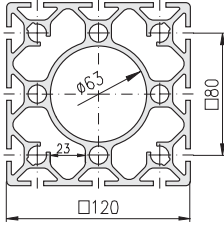

 	 		
<p>Profile 80×160, 12E, P</p>	<p>Profile 120×120, 12E, P</p>		
<p>1.11.080160.124P.60</p>	<p>1.11.120120.123P.60</p>		
<p>1.11.080160.124P.61 (2)</p>	<p>1.11.120120.123P.61 (2)</p>		
<p><math>I_x = 883.0</math> <math>I_y = 269.0</math>  <math>W_x = 110.0</math> <math>W_y = 67.3</math>  <math>G = 9.4</math></p>	<p><math>I_x = 624.0</math> <math>I_y = 624.0</math>  <math>W_x = 104.0</math> <math>W_y = 104.0</math>  <math>G = 10.6</math></p>		





light			Connection possibilities and calculation formulas for polygons ↗ 1.2E
Description		P. 40, rnd. 45 deg., 2E, LP	Profile 40, round 90 deg., 2E, LP
bar, 6 m		1.11.040R45.20LP.60	1.11.040R90.20LP.60
packing unit (number)		1.11.040R45.20LP.61 (8)	1.11.040R90.20LP.61 (4)
moment of inertia $\text{cm}^4$		$I_x = 14.5$ $I_y = 8.0$	$I_x = 89.0$ $I_y = 89.0$
moment of resistance $\text{cm}^3$		$W_x = 4.9$ $W_y = 3.7$	$W_x = 16.0$ $W_y = 16.0$
weight $\text{kg/m}$		$G = 1.6$	$G = 3.0$



light				
Description	Prf. 40x40, 2E, 45 deg., LP	Prf. 80x80, 3E, 45 deg., LP	Prf. 80x80, 7E, 45 deg., LP	
bar, 6 m	1.11.040040.28LP.60	1.11.080080.38LP.60	1.11.080080.78LP.60	
packing unit (number)	1.11.040040.28LP.61 (8)	1.11.080080.38LP.61 (2)	1.11.080080.78LP.61 (2)	
moment of inertia $\text{cm}^4$	$I_x = 7.3$ $I_y = 7.3$	$I_x = 106.0$ $I_y = 106.0$	$I_x = 99.3$ $I_y = 99.3$	
moment of resistance $\text{cm}^3$	$W_x = 3.9$ $W_y = 3.9$	$W_x = 26.5$ $W_y = 26.5$	$W_x = 24.8$ $W_y = 24.8$	
weight $\text{kg/m}$	$G = 1.4$	$G = 4.3$	$G = 4.0$	

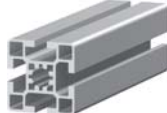

light				
Description	Profile 45×45, 2E, soft, LP	Profile 45×45, 0E, LP	Profile 45×45, 1E, LP	Profile 45×45, 2E, cor., LP
bar, 6 m	1.11.045045.21LP.60	1.11.045045.03LP.60	1.11.045045.13LP.60	1.11.045045.22LP.60
packing unit (number)	1.11.045045.21LP.61 (8)	1.11.045045.03LP.61 (8)	1.11.045045.13LP.61 (8)	1.11.045045.22LP.61 (8)
moment of inertia cm <sup>4</sup>	$I_x = 11.4$ $I_y = 11.4$	$I_x = 15.5$ $I_y = 15.5$	$I_x = 14.7$ $I_y = 15.5$	$I_x = 14.7$ $I_y = 14.7$
moment of resistance cm <sup>3</sup>	$W_x = 5.1$ $W_y = 5.1$	$W_x = 6.9$ $W_y = 6.9$	$W_x = 6.5$ $W_y = 6.8$	$W_x = 6.6$ $W_y = 6.6$
weight kg/m	$G = 1.6$	$G = 2.2$	$G = 2.1$	$G = 2.0$

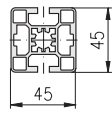
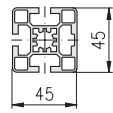
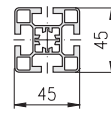
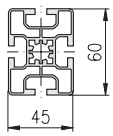
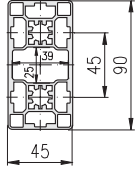
heavy				
Description				
bar, 6 m				
packing unit (number)				
moment of inertia cm <sup>4</sup>				
moment of resistance cm <sup>3</sup>				
weight kg/m				

				
				
Profile 45x45, 2E, LP	Profile 45x45, 3E, LP	Profile 45x45, 4E, LP	Profile 45x60, 4E, LP	Profile 45x90, 0E, LP
1.11.045045.23LP.60	1.11.045045.33LP.60	1.11.045045.43LP.60	1.11.045060.44LP.60	1.11.045090.04LP.60
1.11.045045.23LP.61 (8)	1.11.045045.33LP.61 (8)	1.11.045045.43LP.61 (8)	1.11.045060.44LP.61 (6)	1.11.045090.04LP.61 (4)
$I_x = 14.0$ $I_y = 15.5$ $W_x = 6.2$ $W_y = 6.9$ $G = 2.0$	$I_x = 14.0$ $I_y = 14.7$ $W_x = 6.2$ $W_y = 6.5$ $G = 2.1$	$I_x = 13.5$ $I_y = 13.5$ $W_x = 6.0$ $W_y = 6.0$ $G = 1.9$	$I_x = 26.5$ $I_y = 16.0$ $W_x = 9.0$ $W_y = 7.2$ $G = 2.3$	$I_x = 107.5$ $I_y = 30.4$ $W_x = 23.9$ $W_y = 13.5$ $G = 3.6$

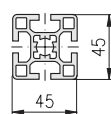
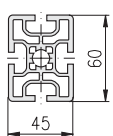
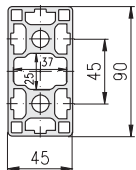
				
				
		Profile 45x45, 4E, P	Profile 45x60, 4E, P	Profile 45x90, 0E, P
		1.11.045045.43P.60	1.11.045060.44P.60	1.11.045090.04P.60
		1.11.045045.43P.61 (8)	1.11.045060.44P.61 (6)	1.11.045090.04P.61 (4)
		$I_x = 15.5$ $I_y = 15.5$ $W_x = 6.9$ $W_y = 6.9$ $G = 2.1$	$I_x = 38.0$ $I_y = 23.5$ $W_x = 13.0$ $W_y = 10.4$ $G = 3.0$	$I_x = 134.3$ $I_y = 36.3$ $W_x = 29.8$ $W_y = 16.2$ $G = 4.7$



light				
Description	Profile 45×90, 6E, LP	Profile 90×90, 8E, LP		
bar, 6 m	1.11.045090.64LP.60	1.11.090090.83LP.60		
packing unit (number)	1.11.045090.64LP.61 (4)	1.11.090090.83LP.61 (2)		
moment of inertia $\text{cm}^4$	$I_x = 98.0$ $I_y = 27.5$	$I_x = 190.5$ $I_y = 190.5$		
moment of resistance $\text{cm}^3$	$W_x = 21.8$ $W_y = 12.2$	$W_x = 42.3$ $W_y = 42.3$		
weight $\text{kg/m}$	$G = 3.3$	$G = 5.6$		



heavy				
Description	Profile 45×90, 6E, P	Profile 90×90, 8E, P		
bar, 6 m	1.11.045090.64P.60	1.11.090090.83P.60		
packing unit (number)	1.11.045090.64P.61 (4)	1.11.090090.83P.61 (2)		
moment of inertia $\text{cm}^4$	$I_x = 126.0$ $I_y = 34.0$	$I_x = 282.0$ $I_y = 282.0$		
moment of resistance $\text{cm}^3$	$W_x = 28.0$ $W_y = 15.0$	$W_x = 63.0$ $W_y = 63.0$		
weight $\text{kg/m}$	$G = 4.4$	$G = 9.5$		

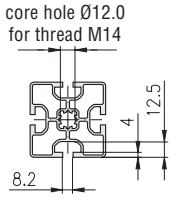
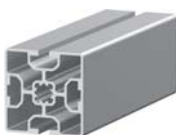

light				

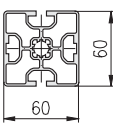
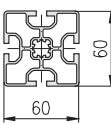
heavy		
Description	Profile 100×200, 12E, P	Profile 100×300, 16E, P
bar, 6 m	1.11.100200.124P.60	1.11.100300.164P.60
packing unit (number)	1.11.100200.124P.61 (2)	1.11.100300.164P.61 (1)
moment of inertia cm <sup>4</sup>	$I_x = 2,450$ $I_y = 760$	$I_x = 8,320$ $I_y = 1,170$
moment of resistance cm <sup>3</sup>	$W_x = 250$ $W_y = 152$	$W_x = 555$ $W_y = 234$
weight kg/m	$G = 17.2$	$G = 25.6$

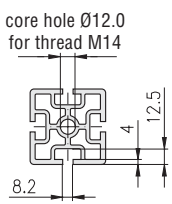
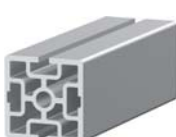
light				
				
				
Description	Profile 60×60, 2E, LP	Profile 60×60, 4E, LP		
bar, 6 m	1.11.060060.23LP.60	1.11.060060.43LP.60		
packing unit (number)	1.11.060060.23LP.61 (6)	1.11.060060.43LP.61 (6)		
moment of inertia cm <sup>4</sup>	$I_x = 35.1$ $I_y = 37.7$	$I_x = 35.5$ $I_y = 35.5$		
moment of resistance cm <sup>3</sup>	$W_x = 11.7$ $W_y = 12.5$	$W_x = 11.7$ $W_y = 11.7$		
weight kg/m	$G = 2.9$	$G = 2.7$		

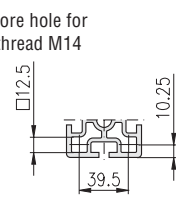
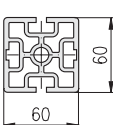
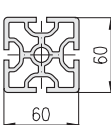





heavy				
				
				
Description	Profile 60×60, 2E, P	Profile 60×60, 4E, P		
bar, 6 m	1.11.060060.23P.60	1.11.060060.43P.60		
packing unit (number)	1.11.060060.23P.61 (6)	1.11.060060.43P.61 (6)		
moment of inertia cm <sup>4</sup>	$I_x = 55.9$ $I_y = 58.5$	$I_x = 56.0$ $I_y = 56.0$		
moment of resistance cm <sup>3</sup>	$W_x = 18.6$ $W_y = 19.5$	$W_x = 18.7$ $W_y = 18.7$		
weight kg/m	$G = 4.3$	$G = 4.2$		





heavy				
Description	Profile 48, round, 1E, P	P. 48, round, 2E, corner, P	Profile 48, round, 2E, P	
bar, 6 m	1.11.048R00.10P.60	1.11.048R00.22P.60	1.11.048R00.20P.60	
packing unit (number)	1.11.048R00.10P.61 (6)	1.11.048R00.22P.61 (6)	1.11.048R00.20P.61 (6)	
moment of inertia cm <sup>4</sup>	I <sub>x</sub> = 12.5 I <sub>y</sub> = 12.9	I <sub>x</sub> = 12.0 I <sub>y</sub> = 12.0	I <sub>x</sub> = 12.5 I <sub>y</sub> = 13.5	
moment of resistance cm <sup>3</sup>	W <sub>x</sub> = 4.9 W <sub>y</sub> = 5.4	W <sub>x</sub> = 5.0 W <sub>y</sub> = 5.0	W <sub>x</sub> = 5.1 W <sub>y</sub> = 5.9	
weight kg/m	G = 1.8	G = 2.0	G = 2.0	

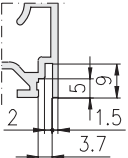

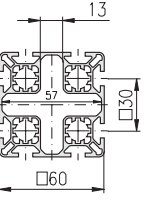
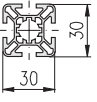
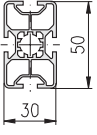
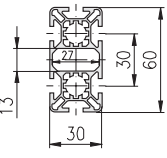

heavy				
Description	Prof. 30, hexagonal, 6F, P	Profile 30, octagonal, 8F, P	Prof. 40, hexagonal, 6E, P	Prof. 40, octagonal, 8E, P
bar, 6 m	1.11.0306kt.69P.60	1.11.0308kt.89P.60	1.11.0406kt.69P.60	1.11.0408kt.89P.60
packing unit (number)	1.11.0306kt.69P.61 (2)	1.11.0308kt.89P.61 (2)	1.11.0406kt.69P.61 (2)	1.11.0408kt.89P.61 (2)
moment of inertia cm <sup>4</sup>	I <sub>x</sub> = 32.0 I <sub>y</sub> = 32.0	I <sub>x</sub> = 84.0 I <sub>y</sub> = 84.0	I <sub>x</sub> = 83.0 I <sub>y</sub> = 83.0	I <sub>x</sub> = 233.0 I <sub>y</sub> = 233.0
moment of resistance cm <sup>3</sup>	W <sub>x</sub> = 9.8 W <sub>y</sub> = 9.8	W <sub>x</sub> = 21.0 W <sub>y</sub> = 21.0	W <sub>x</sub> = 21.0 W <sub>y</sub> = 21.0	W <sub>x</sub> = 44.0 W <sub>y</sub> = 44.0
weight kg/m	G = 2.8	G = 3.9	G = 4.4	G = 6.5

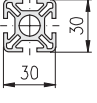
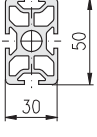
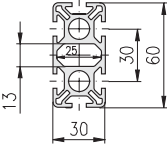
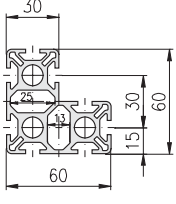

light				
Description		Profile 30×30, 2F, corner, L	Profile 30×30, 2F, L	Profile 30×30, 3F, L
bar, 6 m		1.11.030030.22L.60	1.11.030030.23L.60	1.11.030030.33L.60
packing unit (number)		1.11.030030.22L.61 (10)	1.11.030030.23L.61 (10)	1.11.030030.33L.61 (10)
moment of inertia cm <sup>4</sup>		$I_x = 3.2$ $I_y = 3.2$	$I_x = 3.2$ $I_y = 3.2$	$I_x = 3.3$ $I_y = 3.2$
moment of resistance cm <sup>3</sup>		$W_x = 2.1$ $W_y = 2.1$	$W_x = 2.2$ $W_y = 2.2$	$W_x = 2.2$ $W_y = 2.2$
weight kg/m		G = 0.9	G = 0.9	G = 0.9

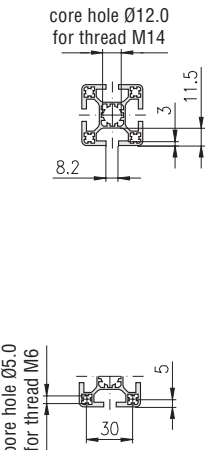

heavy				
Description	Profile 30×30, 2F, soft	Profile 30×30, 2F, corner	Profile 30×30, 2F, corner, B	Profile 30×30, 3F
bar, 6 m	1.11.030030.21.60	1.11.030030.22.60	1.11.030030.22B.60	1.11.030030.33.60
packing unit (number)	1.11.030030.21.61 (10)	1.11.030030.22.61 (10)	1.11.030030.22B.61 (10)	1.11.030030.33.61 (10)
moment of inertia cm <sup>4</sup>	$I_x = 2.7$ $I_y = 2.7$	$I_x = 3.7$ $I_y = 3.7$	$I_x = 3.7$ $I_y = 3.7$	$I_x = 3.5$ $I_y = 3.7$
moment of resistance cm <sup>3</sup>	$W_x = 1.6$ $W_y = 1.6$	$W_x = 2.4$ $W_y = 2.4$	$W_x = 2.4$ $W_y = 2.4$	$W_x = 2.4$ $W_y = 2.4$
weight kg/m	G = 0.9	G = 1.1	G = 1.1	G = 1.1

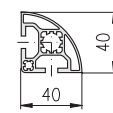
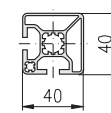
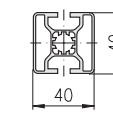
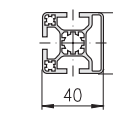

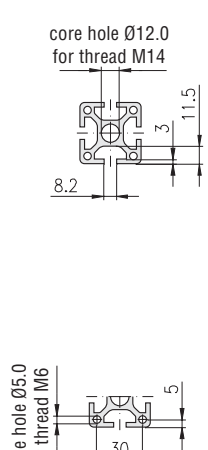
			 	 
				
Profile 30×30, 4F, L	Profile 30×50, 4F, L	Profile 30×60, 6F, L	Profile 30×100, 5F, L	Profile 60×60, 8F, L
1.11.030030.43L.60	1.11.030050.44L.60	1.11.030060.64L.60	1.11.030100.54L.60	1.11.060060.83L.60
1.11.030030.43L.61 (10)	1.11.030050.44L.61 (6)	1.11.030060.64L.61 (6)	1.11.030100.54L.61 (4)	1.11.060060.83L.61 (8)
$I_x = 3.3$ $I_y = 3.3$ $W_x = 2.2$ $W_y = 2.2$ $G = 0.9$	$I_x = 11.0$ $I_y = 4.3$ $W_x = 4.8$ $W_y = 3.3$ $G = 1.3$	$I_x = 21.2$ $I_y = 5.7$ $W_x = 7.0$ $W_y = 3.8$ $G = 1.6$	$I_x = 83.2$ $I_y = 9.5$ $W_x = 16.6$ $W_y = 6.3$ $G = 2.2$	$I_x = 38.7$ $I_y = 38.7$ $W_x = 12.9$ $W_y = 12.9$ $G = 2.6$

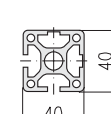
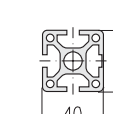
				
				
Profile 30×30, 4F	Profile 30×50, 4F	Profile 30×60, 6F		Profile 60×60, 8F, angle
1.11.030030.43.60	1.11.030050.44.60	1.11.030060.65.60		1.11.060060.87.60
1.11.030030.43.61 (10)	1.11.030050.44.61 (6)	1.11.030060.65.61 (6)		1.11.060060.87.61 (4)
$I_x = 3.5$ $I_y = 3.5$ $W_x = 2.4$ $W_y = 2.4$ $G = 1.1$	$I_x = 16.9$ $I_y = 6.6$ $W_x = 6.7$ $W_y = 4.4$ $G = 2.0$	$I_x = 25.0$ $I_y = 7.0$ $W_x = 8.3$ $W_y = 4.7$ $G = 2.1$		$I_x = 35.2$ $I_y = 35.2$ $W_x = 9.9$ $W_y = 9.9$ $G = 2.8$

light					
					
					
Description		Profile 40×40, 2E, soft, L	Profile 40×40, 2E, corner, L	Profile 40×40, 2E, L	Profile 40×40, 3E, L
bar, 6 m		1.11.040040.21L.60	1.11.040040.22L.60	1.11.040040.23L.60	1.11.040040.33L.60
packing unit (number)		1.11.040040.21L.61 (8)	1.11.040040.22L.61 (8)	1.11.040040.23L.61 (8)	1.11.040040.33L.61 (8)
moment of inertia cm <sup>4</sup>	$I_x = 6.4$ $I_y = 6.4$	$I_x = 8.0$ $I_y = 8.0$	$I_x = 8.2$ $I_y = 7.5$	$I_x = 8.3$ $I_y = 8.8$	
moment of resistance cm <sup>3</sup>	$W_x = 3.8$ $W_y = 3.8$	$W_x = 4.0$ $W_y = 4.0$	$W_x = 4.1$ $W_y = 3.8$	$W_x = 4.1$ $W_y = 4.4$	
weight kg/m	$G = 1.2$	$G = 1.3$	$G = 1.3$	$G = 1.4$	

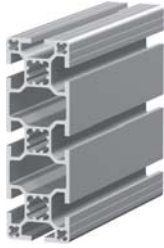
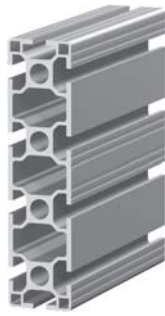
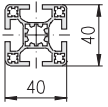
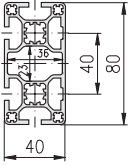
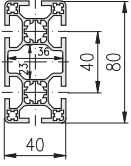
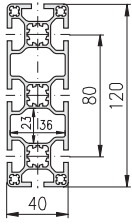
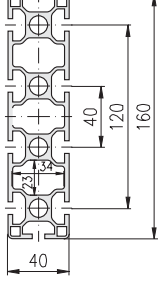
heavy				
				
				
Description		Profile 40×40, 2E, corner	Profile 40×40, 3E	
bar, 6 m		1.11.040040.22.60	1.11.040040.33.60	
packing unit (number)		1.11.040040.22.61 (8)	1.11.040040.33.61 (8)	
moment of inertia cm <sup>4</sup>		$I_x = 12.3$ $I_y = 12.3$	$I_x = 12.0$ $I_y = 12.3$	
moment of resistance cm <sup>3</sup>		$W_x = 6.1$ $W_y = 6.1$	$W_x = 6.0$ $W_y = 6.0$	
weight kg/m		$G = 2.0$	$G = 2.0$	

				
				
Profile 40x40, 4E, L	Profile 40x80, 4E, L	Profile 40x80, 6E, L	Profile 40x120, 8E, L	Profile 40x160, 10E, L
1.11.040040.43L.60	1.11.040080.44L.60	1.11.040080.64L.60	1.11.040120.84L.60	1.11.040160.104L.60
1.11.040040.43L.61 (8)	1.11.040080.44L.61 (4)	1.11.040080.64L.61 (4)	1.11.040120.84L.61 (2)	1.11.040160.104L.61 (2)
$I_x = 9.9$ $I_y = 9.9$ $W_x = 4.9$ $W_y = 4.9$ $G = 1.5$	$I_x = 63.2$ $I_y = 17.8$ $W_x = 15.7$ $W_y = 8.9$ $G = 2.6$	$I_x = 62.7$ $I_y = 17.0$ $W_x = 15.6$ $W_y = 8.5$ $G = 2.6$	$I_x = 194.0$ $I_y = 26.0$ $W_x = 33.0$ $W_y = 13.0$ $G = 3.7$	$I_x = 478.0$ $I_y = 36.6$ $W_x = 60.0$ $W_y = 18.3$ $G = 5.6$

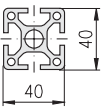
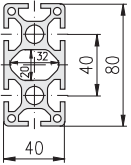
				
				
Profile 40x40, 4E		Profile 40x80, 6E		
1.11.040040.43.60		1.11.040080.65.60		
1.11.040040.43.61 (8)		1.11.040080.65.61 (4)		
$I_x = 12.0$ $I_y = 12.0$ $W_x = 6.0$ $W_y = 6.0$ $G = 2.0$		$I_x = 82.0$ $I_y = 23.4$ $W_x = 20.5$ $W_y = 11.7$ $G = 3.8$		

light				
Description	Profile 80×80, 8E, L	Profile 80×80, 8E, LB	Profile 80×160, 12E, L	
bar, 6 m	1.11.080080.83L.60	1.11.080080.83LB.60	1.11.080160.124L.60	
packing unit (number)	1.11.080080.83L.61 (2)	1.11.080080.83LB.61 (2)	1.11.080160.124L.61 (2)	
moment of inertia cm <sup>4</sup>	$I_x = 111.0$ $I_y = 111.0$	$I_x = 115.0$ $I_y = 115.0$	$I_x = 801.0$ $I_y = 235.0$	
moment of resistance cm <sup>3</sup>	$W_x = 28.0$ $W_y = 28.0$	$W_x = 29.0$ $W_y = 29.0$	$W_x = 100.0$ $W_y = 59.0$	
weight kg/m	$G = 4.1$	$G = 4.5$	$G = 8.8$	

heavy				
Description	Profile 80×80, 8E	Profile 80×80, 8E, angle	Profile 80×160, 12E	
bar, 6 m	1.11.080080.83.60	1.11.080080.87.60	1.11.080160.124.60	
packing unit (number)	1.11.080080.83.61 (2)	1.11.080080.87.61 (2)	1.11.080160.124.61 (2)	
moment of inertia cm <sup>4</sup>	$I_x = 166.0$ $I_y = 166.0$	$I_x = 120.0$ $I_y = 120.0$	$I_x = 880.0$ $I_y = 268.0$	
moment of resistance cm <sup>3</sup>	$W_x = 41.4$ $W_y = 41.4$	$W_x = 23.8$ $W_y = 23.8$	$W_x = 110.0$ $W_y = 67.0$	
weight kg/m	$G = 5.9$	$G = 6.3$	$G = 9.4$	





light	<b>F-Slot</b>			Connection possibilities and calculation formulas for polygons ↗ 1.2E
<b>F-Slot</b>				
core hole Ø12.0 for thread M14 				
<b>E3-Slot</b>				
core hole Ø12.0 for thread M14 				
Description bar, 6 m packing unit (number)	P. 40, round 30 deg., 2F, L 1.11.040R30.20L.60 1.11.040R30.20L.61 (8)	P. 40, round 45 deg., 2E, L 1.11.040R45.20L.60 1.11.040R45.20L.61 (8)	P. 40, round 60 deg., 2E, L 1.11.040R60.20L.60 1.11.040R60.20L.61 (8)	
moment of inertia cm <sup>4</sup> moment of resistance cm <sup>3</sup> weight kg/m	$I_x = 6.0$ $I_y = 4.8$ $W_x = 3.0$ $W_y = 2.4$ $G = 1.2$	$I_x = 14.5$ $I_y = 8.0$ $W_x = 4.9$ $W_y = 3.7$ $G = 1.6$	$I_x = 30.0$ $I_y = 10.5$ $W_x = 7.6$ $W_y = 4.6$ $G = 1.9$	





light			Connection possibilities and calculation formulas for polygons ↗ 1.2E	
core hole Ø12.0 for thread M14 				
Description bar, 6 m packing unit (number)	Profile 40, round 90 deg., 2E, L 1.11.040R90.20L.60 1.11.040R90.20L.61 (4)			
moment of inertia cm <sup>4</sup> moment of resistance cm <sup>3</sup> weight kg/m	$I_x = 89.0$ $I_y = 89.0$ $W_x = 16.0$ $W_y = 16.0$ $G = 3.0$			

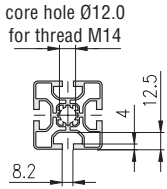

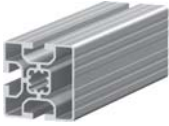
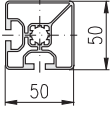
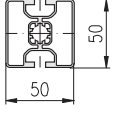
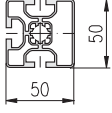
light					
Description	Profile 45×45, 4E, L	Profile 45×60, 4E, L	Profile 45×90, 6E, L	Profile 90×90, 8E, L	
bar, 6 m	1.11.045045.43L.60	1.11.045060.44L.60	1.11.045090.64L.60	1.11.090090.83L.60	
packing unit (number)	1.11.045045.43L.61 (8)	1.11.045060.44L.61 (6)	1.11.045090.64L.61 (4)	1.11.090090.83L.61 (2)	
moment of inertia $\text{cm}^4$	$I_x = 13.5$ $I_y = 13.5$	$I_x = 26.5$ $I_y = 16.0$	$I_x = 98.0$ $I_y = 27.5$	$I_x = 183.0$ $I_y = 183.0$	
moment of resistance $\text{cm}^3$	$W_x = 6.0$ $W_y = 6.0$	$W_x = 9.0$ $W_y = 7.2$	$W_x = 21.8$ $W_y = 12.2$	$W_x = 40.7$ $W_y = 40.7$	
weight $\text{kg/m}$	$G = 1.9$	$G = 2.3$	$G = 3.3$	$G = 5.3$	

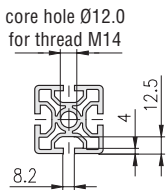

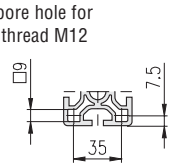
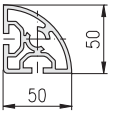
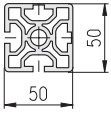
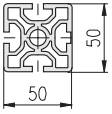

heavy					
Description	Profile 45×45, 4E	Profile 45×60, 4E	Profile 45×90, 6E	Profile 90×90, 8E	
bar, 6 m	1.11.045045.43.60	1.11.045060.44.60	1.11.045090.64.60	1.11.090090.83.60	
packing unit (number)	1.11.045045.43.61 (8)	1.11.045060.44.61 (6)	1.11.045090.64.61 (4)	1.11.090090.83.61 (2)	
moment of inertia $\text{cm}^4$	$I_x = 16.8$ $I_y = 16.8$	$I_x = 38.8$ $I_y = 23.5$	$I_x = 126.0$ $I_y = 34.0$	$I_x = 282.0$ $I_y = 282.0$	
moment of resistance $\text{cm}^3$	$W_x = 7.4$ $W_y = 7.4$	$W_x = 13.0$ $W_y = 10.4$	$W_x = 28.0$ $W_y = 15.0$	$W_x = 63.0$ $W_y = 63.0$	
weight $\text{kg/m}$	$G = 2.3$	$G = 3.0$	$G = 4.4$	$G = 9.5$	

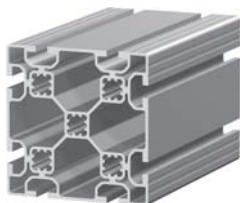
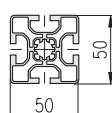
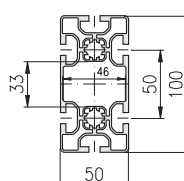
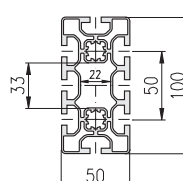
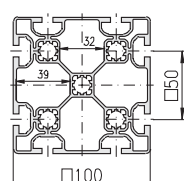

<div style="border: 1px solid black; border-radius: 10px; padding: 2px; display: inline-block;">light</div>				
				
				
Description		Profile 50×50, 2E, corner, L	Profile 50×50, 2E, L	Profile 50×50, 3E, L
bar, 6 m		1.11.050050.22L.60	1.11.050050.23L.60	1.11.050050.33L.60
packing unit (number)		1.11.050050.22L.61 (6)	1.11.050050.23L.61 (6)	1.11.050050.33L.61 (6)
moment of inertia cm <sup>4</sup>		$I_x = 16.5$ $I_y = 16.5$	$I_x = 17.7$ $I_y = 13.6$	$I_x = 18.4$ $I_y = 16.0$
moment of resistance cm <sup>3</sup>		$W_x = 6.7$ $W_y = 6.7$	$W_x = 7.0$ $W_y = 5.4$	$W_x = 7.3$ $W_y = 5.8$
weight kg/m		G = 1.7	G = 1.6	G = 1.9

<div style="border: 1px solid black; border-radius: 10px; padding: 2px; display: inline-block;">heavy</div>				
				
				
Description	Profile 50×50, 2E, soft	Profile 50×50, 2E, corner		Profile 50×50, 3E
bar, 6 m	1.11.050050.21.60	1.11.050050.22.60		1.11.050050.33.60
packing unit (number)	1.11.050050.21.61 (6)	1.11.050050.22.61 (6)		1.11.050050.33.61 (6)
moment of inertia cm <sup>4</sup>	$I_x = 18.8$ $I_y = 18.8$	$I_x = 28.2$ $I_y = 28.2$		$I_x = 27.3$ $I_y = 28.2$
moment of resistance cm <sup>3</sup>	$W_x = 7.5$ $W_y = 7.5$	$W_x = 11.1$ $W_y = 11.1$		$W_x = 11.1$ $W_y = 11.1$
weight kg/m	G = 2.3	G = 3.2		G = 3.1

				
				
Profile 50×50, 4E, L	Profile 50×100, 6E, L	Profile 50×100, 8E, L		Profile 100×100, 8E, L
1.11.050050.43L.60	1.11.050100.64L.60	1.11.050100.84L.60		1.11.100100.83L.60
1.11.050050.43L.61 (6)	1.11.050100.64L.61 (3)	1.11.050100.84L.61 (3)		1.11.100100.83L.61 (2)
$I_x = 19.2$ $I_y = 19.2$ $W_x = 7.7$ $W_y = 7.7$ $G = 2.2$	$I_x = 138.0$ $I_y = 37.0$ $W_x = 27.5$ $W_y = 14.5$ $G = 3.5$	$I_x = 137.0$ $I_y = 40.0$ $W_x = 27.5$ $W_y = 16.0$ $G = 4.0$		$I_x = 284.0$ $I_y = 284.0$ $W_x = 50.8$ $W_y = 50.8$ $G = 6.2$

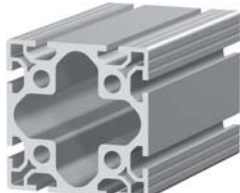
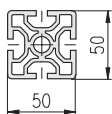
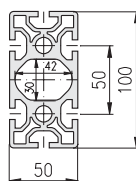
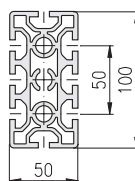
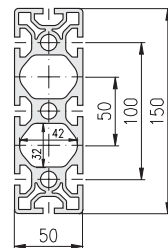
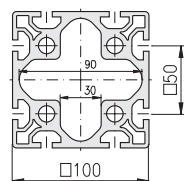



				
				
Profile 50×50, 4E	Profile 50×100, 6E	Profile 50×100, 8E	Profile 50×150, 8E	Profile 100×100, 8E
1.11.050050.43.60	1.11.050100.65.60	1.11.050100.84.60	1.11.050150.85.60	1.11.100100.83.60
1.11.050050.43.61 (6)	1.11.050100.65.61 (3)	1.11.050100.84.61 (3)	1.11.050150.85.61 (2)	1.11.100100.83.61 (2)
$I_x = 27.3$ $I_y = 27.3$ $W_x = 11.0$ $W_y = 11.0$ $G = 3.1$	$I_x = 202.0$ $I_y = 57.2$ $W_x = 40.4$ $W_y = 22.8$ $G = 5.9$	$I_x = 200.0$ $I_y = 53.3$ $W_x = 39.9$ $W_y = 21.3$ $G = 6.0$	$I_x = 628.0$ $I_y = 83.0$ $W_x = 83.0$ $W_y = 33.0$ $G = 8.1$	$I_x = 411.0$ $I_y = 411.0$ $W_x = 82.0$ $W_y = 82.0$ $G = 9.7$

light				
	<p>core hole Ø12.0 for thread M14</p>			
Description	Profile 60×60, 4E, L	Profile 60×90, 6E, L		
bar, 6 m	1.11.060060.43L.60	1.11.060090.64L.60		
packing unit (number)	1.11.060060.43L.61 (6)	1.11.060090.64L.61 (3)		
moment of inertia cm <sup>4</sup>	$I_x = 35.5$ $I_y = 35.5$	$I_x = 124.0$ $I_y = 54.0$		
moment of resistance cm <sup>3</sup>	$W_x = 11.7$ $W_y = 11.7$	$W_x = 27.5$ $W_y = 18.0$		
weight kg/m	$G = 2.7$	$G = 4.0$		



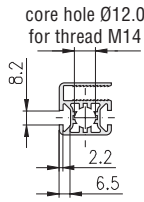

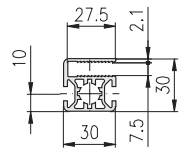
heavy				
	<p>core hole Ø12.0 for thread M14</p>			
Description	Profile 60×60, 4E	Profile 60×90, 6E		
bar, 6 m	1.11.060060.43.60	1.11.060090.64.60		
packing unit (number)	1.11.060060.43.61 (6)	1.11.060090.64.61 (3)		
moment of inertia cm <sup>4</sup>	$I_x = 56.0$ $I_y = 56.0$	$I_x = 193.0$ $I_y = 83.0$		
moment of resistance cm <sup>3</sup>	$W_x = 18.7$ $W_y = 18.7$	$W_x = 43.0$ $W_y = 27.5$		
weight kg/m	$G = 4.2$	$G = 6.0$		

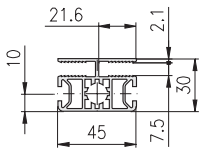
<p>light</p>					
	Description	40x40, 2E, c., Panel, LP 4	40x40, 3E, Panel, LP 4	40x60, 3E, Panel, LP 4	60x80, 5E, Panel, LP 4
	bar, 6 m	1.151.4040.22LP40.60	1.151.4040.33LP40.60	1.151.4060.34LP40.60	1.151.6080.54LP40.60
	packing unit (number)	1.151.4040.22LP40.61 (8)	1.151.4040.33LP40.61 (8)	1.151.4060.34LP40.61 (8)	1.151.6080.54LP40.61 (4)
moment of inertia cm <sup>4</sup>	$I_x = 10.3$ $I_y = 10.3$	$I_x = 10.2$ $I_y = 8.7$	$I_x = 14.8$ $I_y = 26.3$	$I_x = 100.4$ $I_y = 50.4$	
moment of resistance cm <sup>3</sup>	$W_x = 5.2$ $W_y = 5.2$	$W_x = 5.1$ $W_y = 4.3$	$W_x = 7.4$ $W_y = 8.8$	$W_x = 25.1$ $W_y = 16.8$	
weight kg/m	$G = 1.8$ $1.65$	$G =$ $2.4$	$G =$ $3.8$	$G =$	

<p>light</p>	<b>Profile for door stop</b>				
	Description	60x80, 6E, Panel, LP 4	Profile 20x30, 1F, LP	Assembly drawing	Assembly drawing
	bar, 6 m	1.151.6080.64LP40.60	1.11.020030.14LP.60		
packing unit (number)	1.151.6080.64LP40.61 (4)	1.11.020030.14LP.61 (10)			
moment of inertia cm <sup>4</sup>	$I_x = 85.8$ $I_y = 50.8$	$I_x = 2.2$ $I_y = 1.4$	$I_x = 113.0$ $I_y = 64.0$	$I_x = 89.2$ $I_y = 53.3$	
moment of resistance cm <sup>3</sup>	$W_x = 21.5$ $W_y = 16.9$	$W_x = 1.5$ $W_y = 1.4$	$W_x = 28.5$ $W_y = 21.3$	$W_x = 22.3$ $W_y = 17.7$	
weight kg/m	$G = 3.7$	$G = 0.7$	$G = 4.5$	$G = 4.4$	

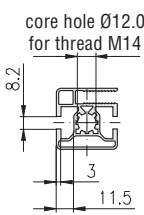
light				
	 	 		
Description	30×30, 2F, WG, LP 7.5	30×45, 2F, WG, LP 7.5		
bar, 6 m	1.155.3030.23LP75.60	1.155.3045.24LP75.60		
packing unit (number)	1.155.3030.23LP75.61 (10)	1.155.3045.24LP75.61 (8)		
moment of inertia cm <sup>4</sup>	$I_x = 2.6$ $I_y = 3.2$	$I_x = 4.3$ $I_y = 7.4$		
moment of resistance cm <sup>3</sup>	$W_x = 1.7$ $W_y = 2.1$	$W_x = 2.9$ $W_y = 3.3$		
weight kg/m	G = 0.86	G = 1.15		

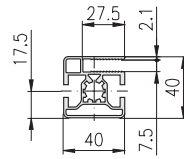
**Wire net profiles 40, E3-slot, P (plain)**

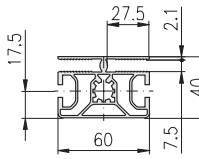
light				
	 	 		
Description	40×40, 2E, WG, LP 7.5	40×60, 2E, WG, LP 7.5		
bar, 6 m	1.155.4040.23LP75.60	1.155.4060.24LP75.60		
packing unit (number)	1.155.4040.23LP75.61 (8)	1.155.4060.24LP75.61 (8)		
moment of inertia cm <sup>4</sup>	$I_x = 7.5$ $I_y = 8.2$	$I_x = 12.0$ $I_y = 22.7$		
moment of resistance cm <sup>3</sup>	$W_x = 3.8$ $W_y = 4.1$	$W_x = 6.0$ $W_y = 7.6$		
weight kg/m	G = 1.35	G = 1.95		

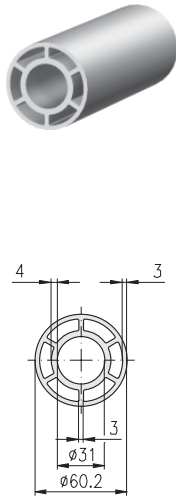
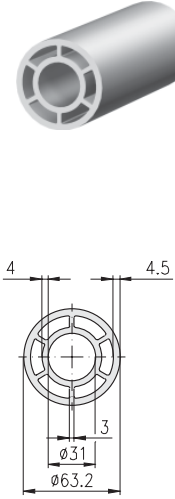
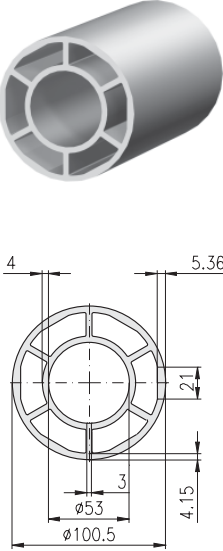
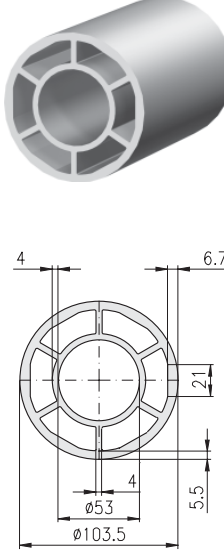

heavy				
Description	Roller profile 60/31	Roller profile 63/31	Roller profile 100/53	Roller profile 103/53
bar, 6 m	5.11.060R00.00P.60	5.11.063R00.00P.60	5.11.100R00.00P.60	5.11.103R00.00P.60
packing unit (Stück)	5.11.060R00.00P.61 (4)	5.11.063R00.00P.61 (4)	5.11.100R00.00P.61 (2)	5.11.103R00.00P.61 (2)
moment of inertia cm <sup>4</sup>	$I_x = 33.4$ $I_y = 33.4$	$I_x = 48.9$ $I_y = 48.9$	$I_x = 225.0$ $I_y = 225.0$	$I_x = 286.0$ $I_y = 286.0$
moment of resistance cm <sup>3</sup>	$W_x = 11.4$ $W_y = 11.4$	$W_x = 15.5$ $W_y = 15.5$	$W_x = 44.7$ $W_y = 44.7$	$W_x = 55.0$ $W_y = 55.0$
weight kg/m	G = 3.2	G = 4.0	G = 6.9	G = 8.3

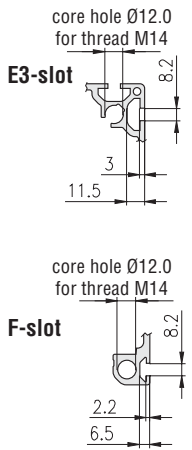
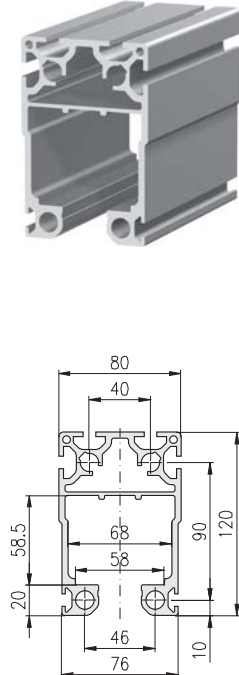
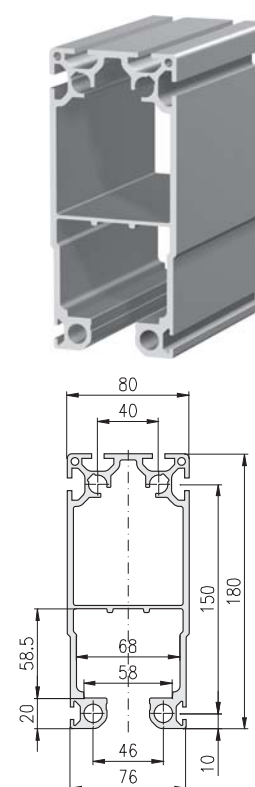
<p style="text-align: center;">heavy</p>  <p><b>E3-slot</b></p> <p>core hole Ø12.0 for thread M14</p> <p><b>F-slot</b></p> <p>core hole Ø12.0 for thread M14</p>		
<b>Description</b>	Carriage support profile 80×120	Carriage support profile 80×180
<b>bar, 6 m</b>	8.11.080120.64P.60	8.11.080180.64P.60
moment of inertia $\text{cm}^4$ moment of resistance $\text{cm}^3$ weight $\text{kg/m}$	$I_x = 354.0$ $I_y = 183.0$ $W_x = 55.0$ $W_y = 46.0$ $G = 5.8$	$I_x = 1,005.0$ $I_y = 252.0$ $W_x = 107.0$ $W_y = 63.0$ $G = 7.1$

<p>heavy</p>		<p>heavy</p>	
<p>Description</p>	<p>Telescopic profile 80×80, 8E, P</p>	<p>Description</p>	<p>Telescopic profile 80×80, 8E, BP</p>
<p>bar, 6 m</p>	<p>9.11.080080.83P.60</p>	<p>bar, 6 m</p>	<p>9.11.080080.83BP.60</p>
<p>moment of inertia <math>cm^4</math> moment of resistance <math>cm^3</math> weight <math>kg/m</math></p>	<p><math>I_x = 166.0</math>   <math>I_y = 166.0</math> <math>W_x = 42.0</math>   <math>W_y = 42.0</math> <math>G = 5.9</math></p>	<p>moment of inertia <math>cm^4</math> moment of resistance <math>cm^3</math> weight <math>kg/m</math></p>	<p><math>I_x = 150.0</math>   <math>I_y = 150.0</math> <math>W_x = 37.5</math>   <math>W_y = 37.5</math> <math>G = 5.3</math></p>

<p>heavy</p>		<p>heavy</p>	
<p>Description</p>	<p>Telescopic profile 120×120, 12E, P</p>	<p>Description</p>	<p>Telescopic profile 160×160, 16E, P</p>
<p>bar, 6 m</p>	<p>9.11.120120.123P.60</p>	<p>bar, 6 m</p>	<p>9.11.160160.163P.60</p>
<p>moment of inertia <math>cm^4</math> moment of resistance <math>cm^3</math> weight <math>kg/m</math></p>	<p><math>I_x = 554.0</math>   <math>I_y = 554.0</math> <math>W_x = 93.0</math>   <math>W_y = 93.0</math> <math>G = 7.8</math></p>	<p>moment of inertia <math>cm^4</math> moment of resistance <math>cm^3</math> weight <math>kg/m</math></p>	<p><math>I_x = 1,424.0</math>   <math>I_y = 1,424.0</math> <math>W_x = 178.0</math>   <math>W_y = 178.0</math> <math>G = 10.7</math></p>



1



Profile pre-cut lids					
<b>Technical data</b> material: Al Mg Si 0.5 F25 tensile strength: 250 N/mm <sup>2</sup> surface: neutral anodised					
Description		Profile pre-cut lid 30	Profile pre-cut lid 40	Profile pre-cut lid 50	Profile pre-cut lid 120
bar, 6 m		1.19.110130.60	1.19.110140.60	1.19.110150.60	1.19.1101120.60
cut to length		1.19.110130-A00A00/...	1.19.110140-A00A00/...	1.19.110150-F00F00/...	1.19.1101120-L00L00/...
weight	kg/m	G = 0.49	G = 0.74	G = 0.85	G = 1.80

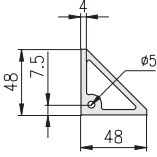
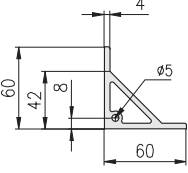
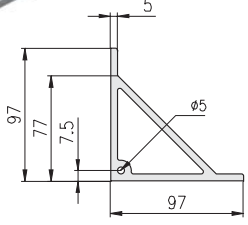

Application  
 E-trunking profiles, 57, 311-313

Hollow profiles					
 As bar item the bore will have machining allowances  <b>Technical data</b> material: Al Mg Si 0.5 F25 tensile strength: 250 N/mm <sup>2</sup> surface: bare					
Description		Hollow profile Ø20	Hollow profile Ø30	Hollow profile Ø40	
bar, 6 m		1.19.12120.60	1.19.12130.60	1.19.12140.60	
cut to length		1.19.12120-A00A00/...	1.19.12130-F00F00/...	1.19.12140-L00L00/...	
weight	kg/m	G = 2.3	G = 4.1	G = 5.5	

Base profiles					
 As bar item the bore will have machining allowances  <b>Technical data</b> material: Al Mg Si 0.5 F25 tensile strength: 250 N/mm <sup>2</sup> surface: bare					
Description		Base profile Ø20	Base profile Ø30	Base profile Ø40	
bar, 6 m		1.19.13120.60	1.19.13130.60	1.19.13140.60	
cut to length		1.19.13120-F00F00/...	1.19.13130-L00L00/...	1.19.13140-L00L00/...	
weight	kg/m	G = 3.9	G = 6.2	G = 8.2	

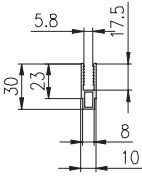
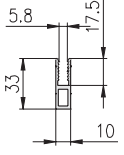



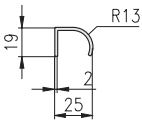
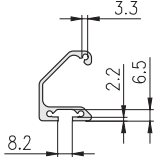
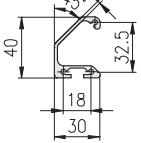

Angle profiles				
<b>Technical data</b> material: Al Mg Si 0.5 F25 tensile strength: 250 N/mm <sup>2</sup> surface: bare				
Description	Angle profile 48x48	Angle profile 60x60	Angle profile 100x100	
bar, 6 m	1.19.141048.60	1.19.141060.60	1.19.141100.60	
cut to length	1.19.141048-F00F00/...	1.19.141060-L00L00/...	1.19.141100-L00L00/...	
weight	kg/m G = 1.9	G = 2.1	G = 5.5	

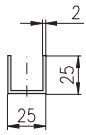
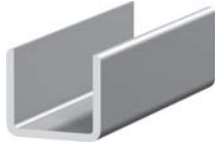
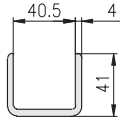
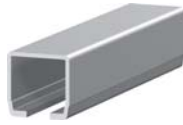
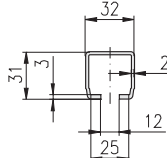

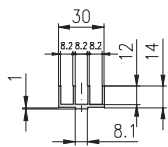
Wire net mounting profiles					
<b>Technical data</b> material: Al Mg Si 0.5 F25 tensile strength: 250 N/mm <sup>2</sup> surface: neutral anodised					
Description	Wire net mounting profile	Wire net mt. pr. 33x10			
bar, 6 m	1.19.14230.60	1.19.1423310.60			
cut to length	1.19.14230-A00A00/...	1.19.1423310-A00A00/...			
weight	kg/m G = 0.3	G = 0.4			

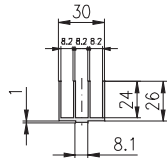

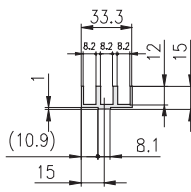
Grab handle profiles				
<b>Technical data</b> material: Al Mg Si 0.5 F25 tensile strength: 250 N/mm <sup>2</sup> surface: neutral anodised				
Description	Grab handle profile			Grab handle profile
bar, 6 m	1.19.14319.60			1.19.14330.60
cut to length	1.19.14319-A00A00/...			1.19.14330-A00A00/...
weight	kg/m G = 0.3			G = 0.73

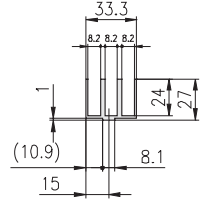

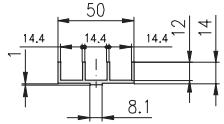

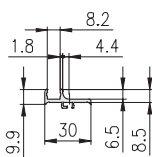
(/... = Length in mm)



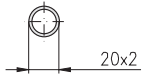
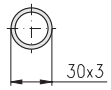
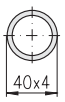

<b>U-profiles, C-track</b>					
<b>Technical data</b> material: Al Mg Si 0.5 F25 tensile strength: 250 N/mm <sup>2</sup> surface: neutral anodised		 	 	 	
Description		U-profile 25×25×2	U-profile 40	C-track	
bar, 6 m		1.19.14425.60	1.19.14440.60	1.19.14532.60	
cut to length		1.19.14425-A00A00/...	1.19.14440-A00A00/...	1.19.14532-A00A00/...	
weight	kg/m	G = 0.4	G = 1.35	G = 0.6	

<b>Sliding profiles</b>					
<b>Technical data</b> material: Al Mg Si 0.5 F25 tensile strength: 250 N/mm <sup>2</sup> surface: neutral anodised		 	 	 	 
Description		Sliding profile 30×14	Sliding profile 30×26	Sliding profile 33×14	Sliding profile 33×26
bar, 6 m		1.19.15130.60	1.19.15131.60	1.19.15133.60	1.19.15134.60
cut to length		1.19.15130-A00A00/...	1.19.15131-A00A00/...	1.19.15133-A00A00/...	1.19.15134-A00A00/...
weight	kg/m	G = 0.4	G = 0.6	G = 0.5	G = 0.8

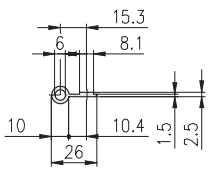
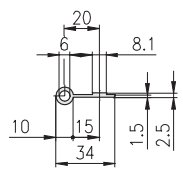
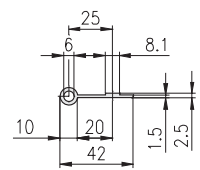
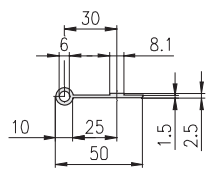



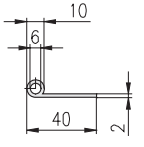
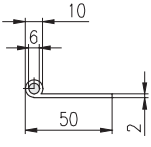
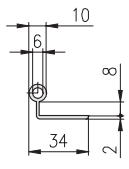
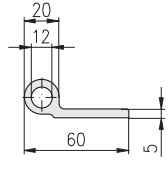

<b>Sliding profile, Panel framing profile</b>					
<b>Technical data</b> material: Al Mg Si 0.5 F25 tensile strength: 250 N/mm <sup>2</sup> surface: neutral anodised		 		 	
Description		Sliding profile 50×14		Panel framing prof. 30×8.5	
bar, 6 m		1.19.15150.60		1.19.15530.60	
cut to length		1.19.15150-A00A00/...		1.19.15530-A00A00/...	
weight	kg/m	G = 0.6		G = 0.27	



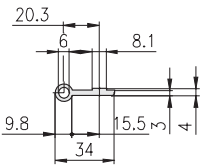

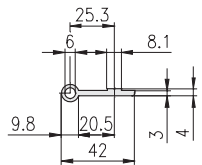

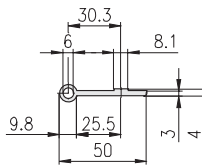
<b>Tubes</b>					
<b>Technical data</b> material: Al Mg Si 0.5 F22 tensile strength: 220 N/mm <sup>2</sup> surface: neutral anodised					
					
	Description	Tube Ø20x2	Tube Ø30x3	Tube Ø40x4	
	bar, 6 m	1.19.16120.60	1.19.16130.60	1.19.16140.60	
cut to length	1.19.16120-A00A00/...	1.19.16130-A00A00/...	1.19.16140-A00A00/...		
weight	kg/m	G = 0.3	G = 0.7	G = 1.3	

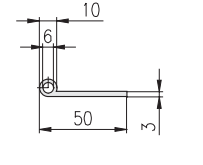

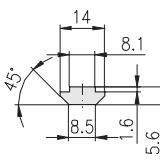
<b>Hinge profiles</b> 1.5 mm					
<b>Technical data</b> material: Al Mg Si 0.5 F25 tensile strength: 250 N/mm <sup>2</sup> surface: neutral anodised					
					
	Description	Type A, PG 20 - 1.5	Type A, PG 30 - 1.5	Type A, PG 40 - 1.5	Type A, PG 50 - 1.5
	bar, 6 m	1.19.1702002.60	1.19.1703002.60	1.19.1704002.60	1.19.1705002.60
cut to length	1.19.1702002-A00A00/...	1.19.1703002-A00A00/...	1.19.1704002-A00A00/...	1.19.1705002-A00A00/...	
weight	kg/m	G = 0.5	G = 0.3	G = 0.3	G = 0.4

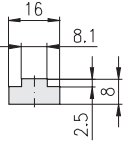
<b>Hinge profiles</b> 2.0 mm			<b>Hinge profile</b> 5.0 mm		
<b>Technical data</b> material: Al Mg Si 0.5 F25 tensile strength: 250 N/mm <sup>2</sup> surface: neutral anodised					
					
	Description	Type B, 40 mm - 2.0	Type B, 50 mm - 2.0	Type C, 30 mm - 2.0	Hinge profile Ø12
	bar, 6 m	1.19.1714002.60	1.19.1715002.60	1.19.1723002.60	1.19.174160.60
cut to length	1.19.1714002-A00A00/...	1.19.1715002-A00A00/...	1.19.1723002-A00A00/...	1.19.174160-A00A00/...	
weight	kg/m	G = 0.3	G = 0.4	G = 0.4	G = 1.25

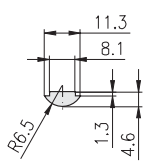
(/... = Length in mm)

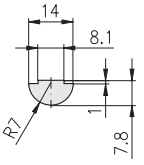

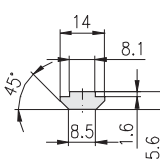

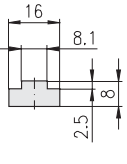
<b>Hinge profiles</b> 3.0 mm  <b>Technical data</b> material: Al Mg Si 0.5 F25 tensile strength: 250 N/mm <sup>2</sup> surface: neutral anodised	 	 	 	 	
	Description	Type A, PG 30 - 3.0	Type A, PG 40 - 3.0	Type A, PG 50 - 3.0	Type B, 50 mm - 3.0
	bar, 6 m	1.19.1703003.60	1.19.1704003.60	1.19.1705003.60	1.19.1715003.60
	cut to length	1.19.1703003-A00A00/...	1.19.1704003-A00A00/...	1.19.1705003-A00A00/...	1.19.1715003-A00A00/...
	weight	kg/m G = 0.4	G = 0.5	G = 0.6	G = 0.5



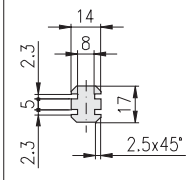

<b>T-Slot profiles</b> Steel  <b>Technical data</b> material: steel C 45 K surface: bare	 	 	 	 	
	Description	T-Slot profile, steel, F	T-Slot profile, steel E	T-Slot profile, steel, for subsequent insertion F	T-Slot profiles, steel, for subsequent insertion E
	bar, 3 m	1.19.1832F.30	1.19.1832E.30	1.19.1834F.30	1.19.1834E.30
	cut to length	1.19.1832F-A00A00/...	1.19.1832E-A00A00/...	1.19.1834F-A00A00/...	1.19.1834E-A00A00/...
	weight	kg/m G = 0.48	G = 0.96	G = 0.24	G = 0.63

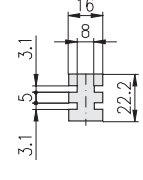

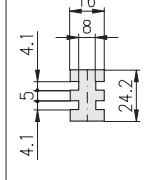

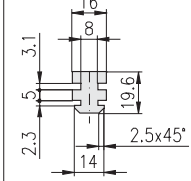
<b>T-Slot profiles</b> PA  <b>Technical data</b> material: PA, murlubric surface: black	 	 			
	Description	T-Slot profile, PA, F	T-Slot profile, PA, E		
	bar, 2 m	1.19.1842F.20	1.19.1842E.20		
	cut to length	1.19.1842F-A00A00/...	1.19.1842E-A00A00/...		
	weight	kg/m G = 0.07	G = 0.14		

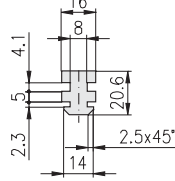

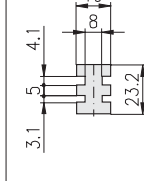

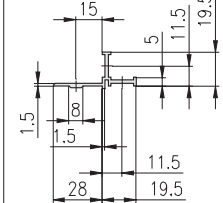

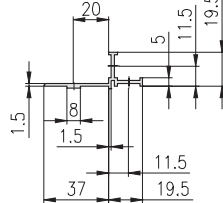

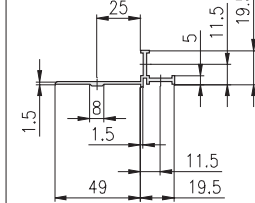
1

Slide-slot profiles PA				
<b>Technical data</b> material: PA, murlubric surface: black	 	 	 	
	Description	Slide-slot profile, PA, F	Slide-slot profile, PA, E3	Slide-slot profile, PA, E4
bar, 2 m	1.19.185F2F2.20	1.19.185E3E3.20	1.19.185E4E4.20	
cut to length	1.19.185F2F2-A00A00/...	1.19.185E3E3-A00A00/...	1.19.185E4E4-A00A00/...	
weight	kg/m G = 0.21	G = 0.35	G = 0.46	

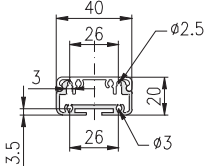

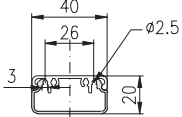
Slide-slot profiles PA				
<b>Technical data</b> material: PA, murlubric surface: black	 	 	 	
	Description	Slide-slot prof., PA, F/E3	Slide-slot prof., PA, F/E4	Slide-slot prof., PA, E3/E4
bar, 2 m	1.19.185F2E3.20	1.19.185F2E4.20	1.19.185E3E4.20	
cut to length	1.19.185F2E3-A00A00/...	1.19.185F2E4-A00A00/...	1.19.185E3E4-A00A00/...	
weight	kg/m G = 0.27	G = 0.32	G = 0.41	

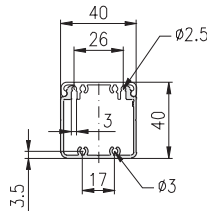

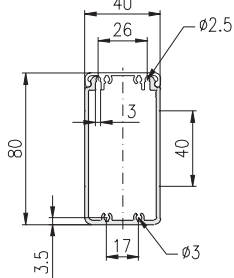
19" profiles				
<b>Technical data</b> material: Al Mg Si 0.5 F25 tensile strength: 250 N/mm <sup>2</sup> surface: neutral anodised	 	 	 	
	Description	19" profile, PG 30	19" profile, PG 40	19" profile, PG 50
bar, 6 m	1.19.19030.60	1.19.19040.60	1.19.19050.60	
cut to length	1.19.19030-A00A00/...	1.19.19040-A00A00/...	1.19.19050-A00A00/...	
weight	kg/m G = 0.4	G = 0.45	G = 0.5	

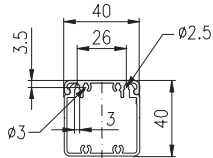

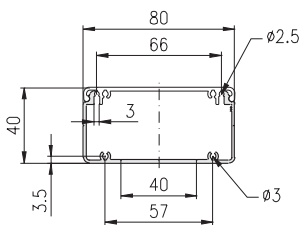
(/... = Length in mm)

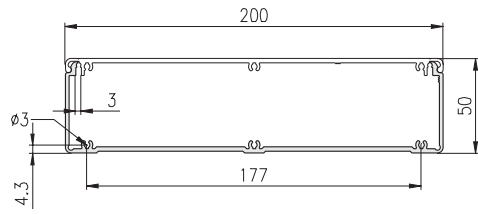
<p><b>E-trunking profiles</b> Base profile for clips Base profiles</p> <p><b>Technical data</b> material: Al Mg Si 0.5 F25 tensile strength: 250 N/mm<sup>2</sup> surface: neutral anodised</p>	 	 	 	 	
	Description	E-trunking profile 40x20, C	E-trunking profile 40x20	E-trunking profile 40x40	E-trunking profile 40x80
	bar, 6 m	1.19.214020G.60	1.19.204020G.60	1.19.204040G.60	1.19.204080G.60
	packing unit (number)	1.19.214020G.61 (16)	1.19.204020G.61 (16)	1.19.204040G.61 (8)	1.19.204080G.61 (4)
	cut to length	1.19.214020G-A00A00/...	1.19.204020G-A00A00/...	1.19.204040G-A00A00/...	1.19.204080G-A00A00/...
weight kg/m	G = 0.50	G = 0.30	G = 0.61	G = 0.85	

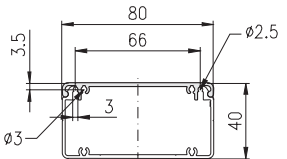
<p><b>E-trunking profiles</b> Cover profile</p> <p><b>Technical data</b> material: Al Mg Si 0.5 F25 tensile strength: 250 N/mm<sup>2</sup> surface: neutral anodised</p>	 	
	Description	E-trunking profile, lid 40
	bar, 6 m	1.19.2040D.60
	packing unit (number)	1.19.2040D.61 (8)
	cut to length	1.19.2040D-A00A00/...
weight kg/m	G = 0.35	

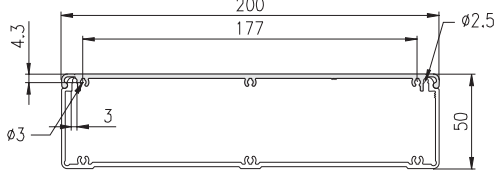
<b>E-trunking profiles</b> Base profiles	 	 
	<b>Technical data</b> material: Al Mg Si 0.5 F25 tensile strength: 250 N/mm <sup>2</sup> surface: neutral anodised	
Description	E-trunking profile 80x40	E-trunking profile 200x50
bar, 6 m	1.19.208040G.60	1.19.220050G.60
packing unit (number)	1.19.208040G.61 (4)	1.19.220050G.61 (2)
cut to length	1.19.208040G-A00A00/...	1.19.220050G-L00L00/...
weight kg/m	G = 1.20	G = 2.00

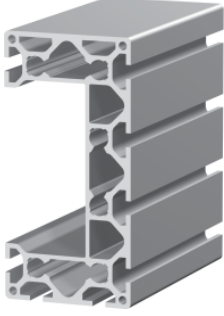
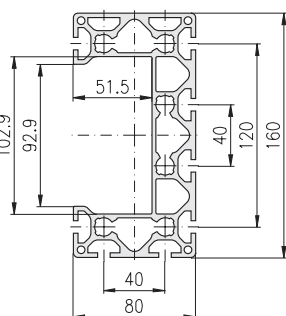
<b>E-trunking profiles</b> Cover profiles	 	 
	<b>Technical data</b> material: Al Mg Si 0.5 F25 tensile strength: 250 N/mm <sup>2</sup> surface: neutral anodised	
Description	E-trunking profile, lid 80	E-trunking profile, lid 200
bar, 6 m	1.19.2080D.60	1.19.2200D.60
packing unit (number)	1.19.2080D.61 (4)	1.19.2200D.61 (2)
cut to length	1.19.2080D-A00A00/...	1.19.2200D-L00L00/...
weight kg/m	G = 0.59	G = 1.50

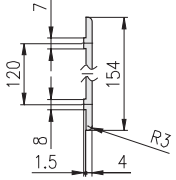
<b>E-trunking profile</b>	Base profile: Profile 80x160, 8E, P ↗ 24, 311-313  	Cover profile: Profile pre-cut lid 120 ↗ 50, 311-313  
	<b>Technical data</b> material: Al Mg Si 0.5 F25 tensile strength: 250 N/mm <sup>2</sup> surface: neutral anodised	
Description	Profile 80x160, 8E, P	Profile pre-cut lid 120
bar, 6 m	1.11.080160.89P.60	1.19.1101120.60
packing unit (number)	1.11.080160.89P.61 (2)	1.19.1101120-L00L00/... (cut to length)
moment of inertia cm <sup>4</sup>	I <sub>x</sub> = 944.0 I <sub>y</sub> = 183.0	
moment of resistance cm <sup>3</sup>	W <sub>x</sub> = 118.0 W <sub>y</sub> = 45.8	
weight kg/m	G = 7.9	G = 1.80

(/... = Length in mm); machining data ↗ Profile machining 1.1A

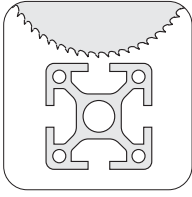
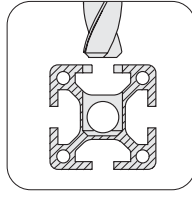
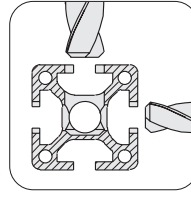
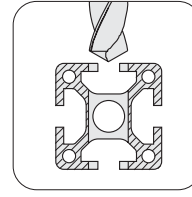
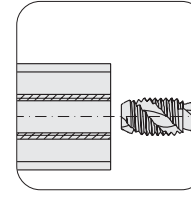
Summary				
 <p>Saw cut</p> <p>↔ 59</p>	 <p>Cross bushing bores for connectors</p> <p>↔ 60</p>	 <p>Bores for parallel-connector</p> <p>↔ 60</p>	 <p>Cross bore</p> <p>↔ 60</p>	 <p>Thread</p> <p>↔ 60</p>
<p><b>Comments</b></p> <ul style="list-style-type: none"> <li>• Profile machinings are defined by the article-number of the profile.</li> <li>• For more complex machinings, additional order descriptions are needed.</li> <li>• Non-standard machinings will be completed as per drawings</li> </ul>				

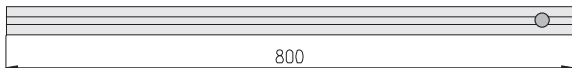
Order description		
<b>Profile</b>	<b>machining</b>	profile side
Order-No.: 1.□□.□□□□□□.□□□□ - □□□□□□ / □□□□	left right	
	□ □ □ □ / □ □ □ □	saw cut ↔ 59
	□ □ □ □ □ / □ □ □ □	cross bushing bores, bores for parallel-connector, cross bore, thread ↔ 60
	□ □ □ □ □ / □ □ □ □	direction ↔ 60
	□ □ □ □ □ / □ □ □ □	length in mm ↔ 60
Order example		
		
<p><b>Description</b></p> <p>Profile 40×40, 4E-slots</p> <p>Length: 800 mm</p> <p>right side: 1 connector bore</p>	<p><b>Article-No.</b></p> <p>1.11.040040.43-A00AA4/800</p>	<p><b>Article-Description</b></p> <p>Profile 40×40, 4E-slots</p> <p>□□□□ ....</p> <p>Specifications for special profile machining</p>

coding examples ↔ 1.1B

**Saw cut**

Saw cut tolerance:  $\pm 0.1$  mm

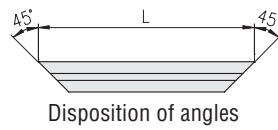
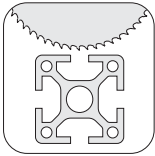

**Cut is right view**

- For angle cuts specify the absolute length
- Angle cuts without specification = 45°

Specification for special angle:

Special angle, left: °

Special angle, right: °

**Price group 1**

- A 0°
- B - 45° to the vertical
- C + 45° to the vertical
- D - 45° to the horizontal
- E + 45° to the horizontal

<b>16</b> 16x40	<b>20</b> 20x10 20x30
1F 1E	1F LP 1F LP 2F LP
<b>20</b> 20x20	20x40 40x40
2H soft 2H c. 2H 3H 4H	4H 6H 8H
<b>30</b> 30x30	30x50 30x60 30x30 30x45
2F soft 0F 1F 2F c. 2F c. B 2F 3F 4F	4F 0F 6F 2F 2F
<b>40</b> 40x40	40 r.30° 40 r.45° 40x40 40x40 40x40
2E soft 0E 1E 2E c. 2E 3E 4E	2F 2E 2E 45° 2E c. 3E 2E
<b>45</b> 45x45	
2E soft 0E 1E 2E c. 2E 3E 4E	
<b>50</b> 50x50	<b>S</b> 48 round
2E soft 2E c. 2E 3E 4E	1E 2E c. 2E

**Price group 2**

- F 0°
- G - 45° to the vertical
- H + 45° to the vertical
- J - 45° to the horizontal
- K + 45° to the horizontal

<b>16</b> 16x80	<b>30</b> 30x100	60x60
2E	5F 5E 2F 8F 9F 10F	0F 8F 8F angle
<b>40</b> 40x60 40x80 40x120	40 r.60°	40x60 40x60
0E 0E 3E c. 4E 4E B 5E 6E 8E	2E	2E 3E
<b>45</b> 45x60 45x90	<b>50</b> 50x100	<b>60</b> 60x60
4E 0E 6E	6E 8E	2E 4E
		<b>S</b> 30 hexag. 6F

**Price group 3**

- L 0°
- M - 45° to the vertical
- N + 45° to the vertical
- O - 45° to the horizontal
- P + 45° to the horizontal

<b>16</b> 16x160	<b>30</b> 30x150	<b>40</b> 40x160	80x120 80x160 40 r.90°
4E	8F 8E	6E 10E	10E 8E 8E 12E 2E
<b>40</b> 80x80	120x120		
0E 4E c. 6E 7E 8E 8E B 8E angle 3E 45° 7E 45°	12E		
<b>45</b> 90x90	<b>50</b> 50x150	<b>60</b> 60x90	
8E	8E	6E	
	100x100 100x200 100x300		
	8E 12E 16E		
		<b>S</b> 30 octag. 40 hexag. 40 octag.	
		8F 6E 8E	

**Cross boring bore for connector**

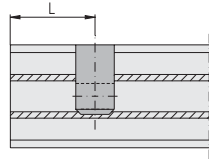
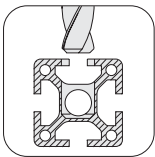

number of bores  
 1 = **A**     7 = **G**  
 2 = **B**     8 = **H**  
 3 = **C**     9 = **I**  
 4 = **D**     10 = **K**  
 5 = **E**     12 = **X**  
 6 = **F**  
 0 = without machining

Disposition rule for connectors at opposed profile sides		
Specified Direction	Position of bore	Example
1	Side 1 and Side 3	
2	Side 2 and Side 4	

Specification for special position:

Position for cross boring bore, left:    ...  
 Position for cross boring bore, right:    ...  
 initials (→ 61, „Direction and Position“)

**Bores for parallel-connector**

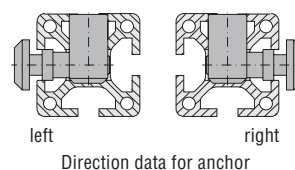
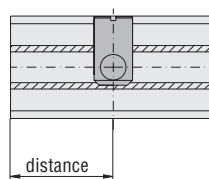
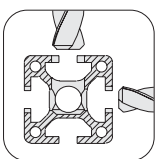

Parallel-connector = **Z**  
 without machining = 0

Specification for parallel-connector:

text	distance	direction
Parallel-connector, distance left:	<input type="text"/> <input type="text"/> <input type="text"/> mm,	anchor left / right
Parallel-connector, distance right:	<input type="text"/> <input type="text"/> <input type="text"/> mm,	anchor left / right

**Cross bore**

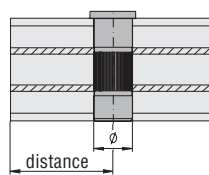
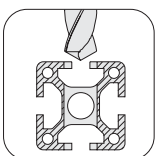

Cross bore = **Q**  
 without machining = 0

Specification for cross bore:

Cross bore, left:     Ø  mm, distance   mm  
 Cross bore, right:     Ø  mm, distance   mm

**Thread**

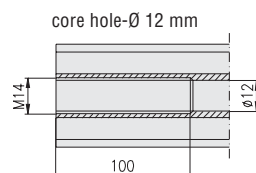
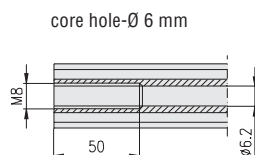
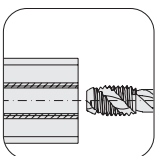

number of threads  
 1 = **L**     7 = **T**  
 2 = **M**     8 = **U**  
 3 = **N**     9 = **V**  
 4 = **P**     10 = **W**  
 5 = **R**     12 = **Y**  
 6 = **S**  
 0 = without machining

Specification for special thread designs:

Depth of thread, left:        ... mm  
 Depth of thread, right:        ... mm  
 Position of thread, left:        ...  
 Position of thread, right:        ...  
 small letters (→ 61, „Direction and Position“)



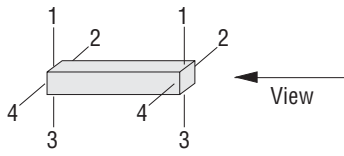





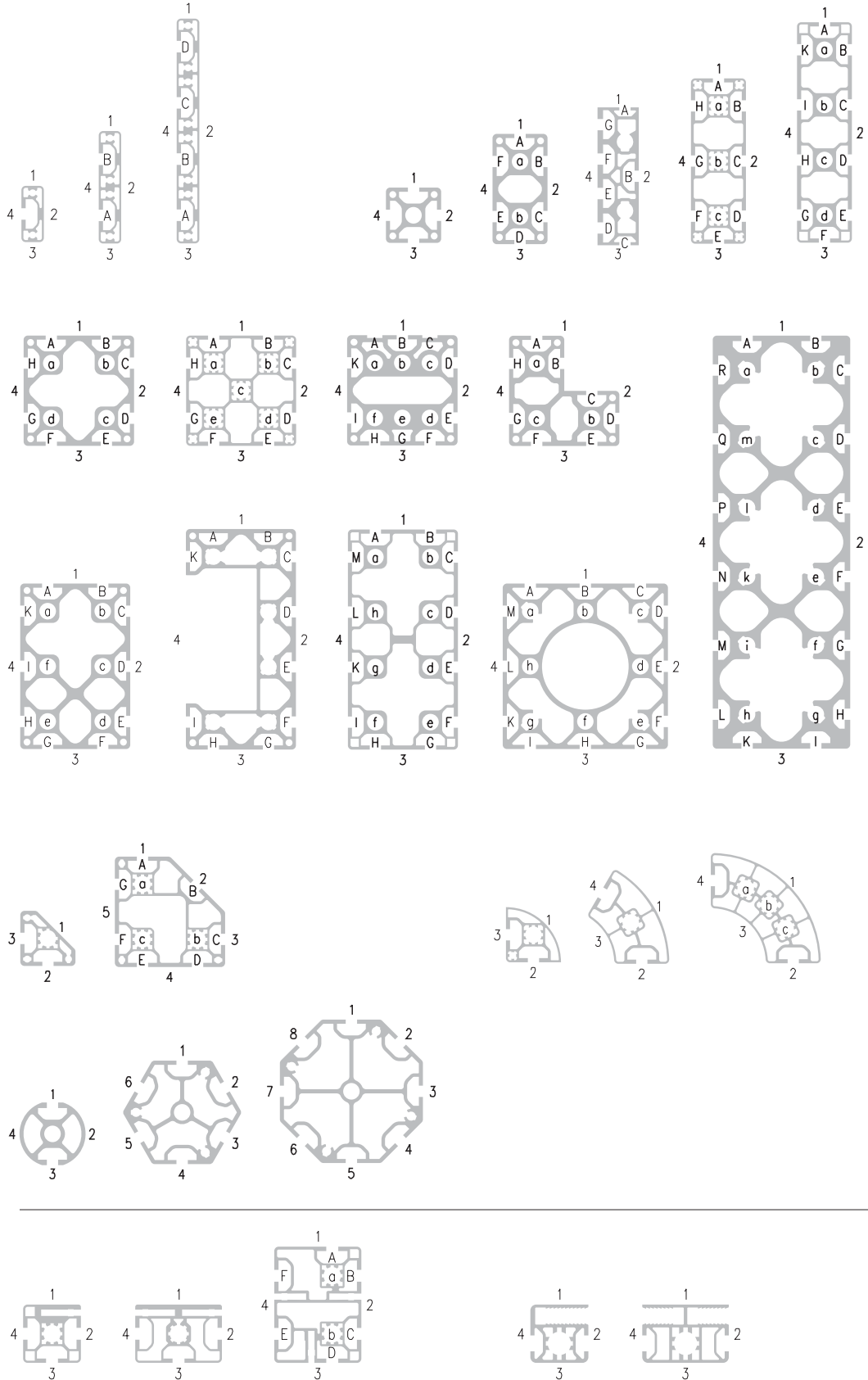



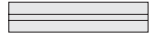

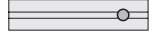



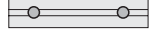









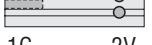
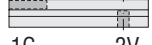
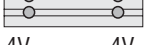
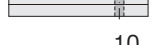
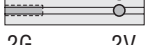
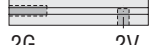
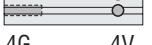



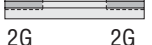
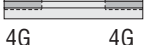
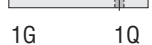

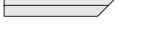

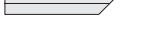



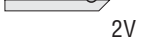



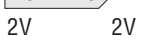

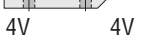

Direction and Position



Description

Direction: 1 - 4  
 Position of slot: A - R  
 Position of thread: a - m















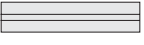

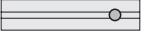

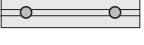









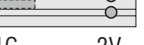
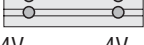
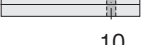
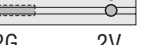





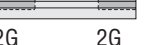
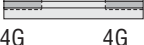
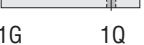



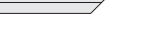





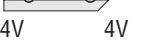

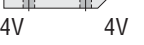
Coding examples for price group 1			
			
 -A00A00	 -A00A00		 -A00A00
 -A00AA4 1V	 -A00AB4 2V	 -A00AB1 2V	 -A00AB4 2V
 -AA4AA4 1V 1V	 -AB4AB4 2V 2V	 -AB1AB1 2V 2V	 -AB4AB4 2V 2V
 -A00AL0 1G	 -A00AL0 1G		 -A00AD2 4V
 -AL0AL0 1G 1G	 -AL0AL0 1G 1G		 -AB4AD2 2V 4V
 -AL0AA4 1G 1V	 -AL0AB4 1G 2V	 -AL0AB1 1G 2V	 -AD2AD2 4V 4V
 -A00AQ1 1Q	 -AM0AB4 2G 2V	 -AM0AB1 2G 2V	 -AP0AD2 4G 4V
 -AA4AQ1 1V 1Q	 -A00AM0 2G		 -A00AP0 4G
 -AQ1AQ1 1Q 1Q	 -AM0AM0 2G 2G		 -AP0AP0 4G 4G
 -AL0AQ1 1G 1Q	 -AL0AM0 1G 2G		 -A00C00
 -A00C00	 -A00C00	top view  -A00E00	 -A00CD2 4V
 -A00CA4 1V	 -A00CB4 2V	 -A00EB1 2V	 -AD2CD2 4V 4V
 -AA4CA4 1V 1V	 -AB4CB4 2V 2V	 -AB1EB1 2V 2V	 -AD1CD1 4V 4V
 -AL0CA4 1G 1V	 -AL0CB4 1G 2V	 -AL0EB1 1G 2V	 -C00C00
 -C00C00	 -C00C00	 -E00E00	 -CD2CD2 4V 4V
 -CA4CA4 1V 1V	 -CB4CB4 2V 2V	 -EB1EB1 2V 2V	 -CD1CD1 4V 4V

V = connector bore, G = thread, Q = cross bore

















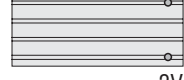
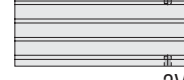

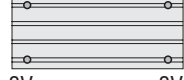
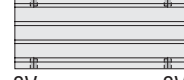
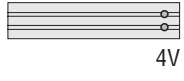
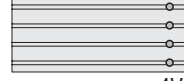
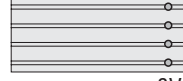



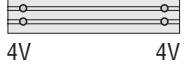

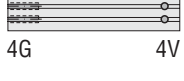
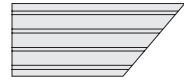
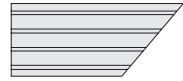

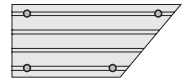
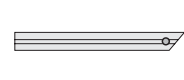
Coding examples for price group 2

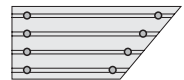
	 	
 -F00F00	 -F00F00	 -F00F00
 -F00FA4 1V	 -F00FB4 2V	 -F00FB1 2V
 -FA4FA4 1V 1V	 -FB4FB4 2V 2V	 -FB1FB1 2V 2V
 -F00FLO 1G	 -F00FLO 1G	 -F00FD2 4V
 -FLOFLO 1G 1G	 -FLOFLO 1G 1G	 -FB4FD2 2V 4V
 -FLOFA4 1G 1V	 -FLOFB4 1G 2V	 -FD2FD2 4V 4V
 -F00FQ1 1Q	 -FM0FB4 2G 2V	 -FM0FB1 2G 2V
 -FA4FQ1 1V 1Q	 -F00FM0 2G	 -F00FP0 4G
 -FQ1FQ1 1Q 1Q	 -FM0FM0 2G 2G	 -FP0FP0 4G 4G
 -FLOFQ1 1G 1Q	 -FLOFM0 1G 2G	 -F00H00
 -F00H00	 -F00H00	 -F00K00 top view
 -F00HA4 1V	 -F00HB4 2V	 -F00KB1 2V
 -FA4HA4 1V 1V	 -FB4HB4 2V 2V	 -FD2HD2 4V 4V
 -FLOHA4 1G 1V	 -FLOHB4 1G 2V	 -FD1HD1 4V 4V
 -H00H00	 -H00H00	 -H00H00
 -HA4HA4 1V 1V	 -HB4HB4 2V 2V	 -HD2HD2 4V 4V
		 -HD1HD1 4V 4V

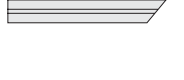
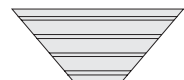
V = connector bore, G = thread, Q = cross bore

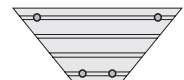
Coding examples for price group 3

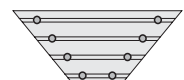
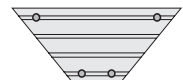
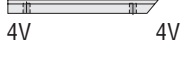
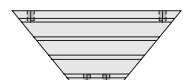
		
 -L00L00	 -L00L00	 -L00L00
 -L00LB4 2V	 -L00LB4 2V	 -L00LB1 2V
 -LB4LB4 2V 2V	 -LB4LB4 2V 2V	 -LB1LB1 2V 2V
 -L00LD2 4V	 -L00LD4 4V	 -L00LH2 8V
 -LB4LD2 2V 4V	 -LD4LD4 4V 4V	 -LH2LH2 8V 8V
 -LD2LD2 4V 4V	 -L00LM0 2G	 -L00LU0 8G
 -LP0LD2 4G 4V	 -L00N00	 -L00N00
 -L00LP0 4G	 -LB4NB4 2V 2V	 -L00PB1 2V
 -LP0LP0 4G 4G	 -LD4ND4 4V 4V	 -LB1PB1 2V 2V
 -L00N00	 -N00N00	 -P00P00
 -LL0ND2 1G 4V	 -NB4NB4 2V 2V	 -PB1PB1 2V 2V
 -LD2ND2 4V 4V	 -ND4ND4 4V 4V	 -L00ND2 4V 4V
 -LD1ND1 4V 4V		 -ND1ND1 4V 4V

top view

Order examples for special design

Article-No..	Description
① 1.11.□□□□□□.□□□□ -L00LD2	Profile □□□×□□□.□□ Connector position, right: CFIM (additional description)
② 1.11.□□□□□□.□□□□ -LD2LD2	Profile □□□×□□□.□□ Connector position, left: CFIM (additional description) Connector position, right: CFIM
③ 1.11.□□□□□□.□□□□ -L00ND2	Profile □□□×□□□.□□ Connector position, right: CFIM (additional description)
④ 1.11.□□□□□□.□□□□ -ND2ND2	Profile □□□×□□□.□□ Connector position, left: CFIM (additional description) Connector position, right: CFIM

V = connector bore, G = thread, Q = cross bore

**Extruded profile**  
**as per DIN EN 12020-1**  
 (fine)  
 (Replacement for DIN 17615)

Aluminium alloy Al Mg Si 0.5 F25  
 Material Nr. 3.3206.72 (low temp. annealed)

**Functional length: 6,000 mm**  
**Delivery length: 6,060 mm + 10 mm**

**Mechanical data**

(Values given in the direction of the press flow)  
 Tensile strength  $R_m$ : min. 250 N/mm<sup>2</sup>  
 Elongation 0.2: min. 200 N/mm<sup>2</sup>  
 Stress point  $A_5$ : min. 10 %  
 Stress point  $A_{10}$ : min. 8 %  
 E-Module: approx. 70,000 N/mm<sup>2</sup>  
 Brinell hardness: approx. 75 HB 2.5/187.5  
 Co-efficient of elongation:  $23.8 \times 10^{-6}/K$

Surface as per DIN 17611:  
 E6/EV1 - dull finish and anodised colours  
 Coat thickness approx. 10  $\mu$ m  
 Coat hardness 250-350 HV  
 Special colours upon request.  
 The surface area - subject to technical procedure - can show optical changes.

**Profile tolerance**  
 (Excerpt from DIN EN 12020-2)

Nominal dimensions:  
 The dimension deviation depends on the precision with which the tooling is manufactured, the tooling wear and the variation during the extrusion process. For one manufacturing setup the variation within one profile is 0.01 mm.

Profile tolerance		
Dim. range in mm		Tolerance in mm
from	to	
-	10	$\pm 0.15$
10	15	$\pm 0.20$
15	30	$\pm 0.25$
30	45	$\pm 0.30$
45	60	$\pm 0.40$
60	90	$\pm 0.45$
90	120	$\pm 0.60$
120	150	$\pm 0.80$
150	180	$\pm 1.00$
180	240	$\pm 1.20$
240	300	$\pm 1.50$

**Flatness of profile surfaces**

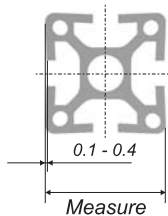

In order to optimize the connection stability, all profile surfaces are designed and manufactured with concave surfaces. This assures that the assembled profiles contact on the outer edges only (line of contact).  
 When tightening the connectors the slot flanks will be drawn to the mounting profile within the elastic range and will keep the connectors under tension.

**Straightness tolerance**  
 of the edge in longitudinal direction

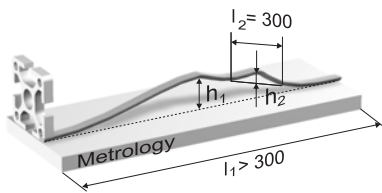

At a certain length  $l_1$  the given tolerance  $h_1$  is not to be exceeded.  
 For each incremental length of  $l_2 = 300$  mm the deviation  $h_2$  is not to exceed 0.3 mm.

Straightness tolerance		
Length $l_1$ in m		Tolerance $h_1$ in mm
from	to	
-	1	0.7
1	2	1.3
2	3	1.8
3	4	2.2
4	5	2.6
5	6	3.0

**Flatness tolerance**  
 (Twist tolerance)

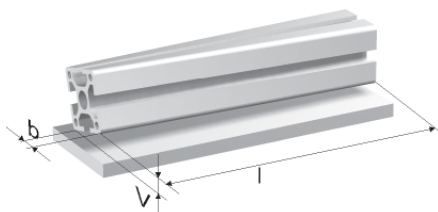

Width $b$ in mm		Flatness tolerance					
Dim. range		at length $l$ in m					
from	to	to 1	1 to 2	2 to 3	3 to 4	4 to 5	5 to 6
-	25	1.0	1.5	1.5	2.0	2.0	2.0
25	50	1.0	1.2	1.5	1.8	2.0	2.0
50	75	1.0	1.2	1.2	1.5	2.0	2.0
75	100	1.0	1.2	1.5	2.0	2.2	2.5
100	125	1.0	1.5	1.8	2.2	2.5	3.0
125	150	1.2	1.5	1.8	2.2	2.5	3.0
150	200	1.5	1.8	2.2	2.6	3.0	3.5
200	300	1.8	2.5	3.0	3.5	4.0	4.5

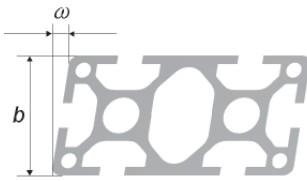
**Parallelism tolerance**  
 (Angular tolerance)

The parallelism tolerance  $\omega$  (angular tolerance) refers to unequal sides to the shorter side of the angle, i.e. it is measured from the longer side.

Parallelism tolerance		
Width $b$ in mm from	to	max. size tolerance $\omega$ in mm
-	30	0.3
30	50	0.4
50	80	0.5
80	100	0.6
100	120	0.7
120	140	0.8
140	160	0.9
160	180	1.0
180	200	1.2
200	240	1.5

**Bending strength**

For the computation of deflection use formulas on this page.

For the computation of deflection by the profiles own weight, apply "Type of load" 3, 6 or 9.

$f$  = Deflection in mm  
 $F$  = Type of load in N  
 $l$  = Profile length in mm  
 $J^{1)}$  = Moment of inertia in  $\text{mm}^4$   
 $E$  = Module of elasticity in  $\text{N/mm}^2$   
 $E_{AL}$  =  $70,000 \text{ N/mm}^2$

**1) Comments**

- Catalogue data in  $\text{cm}^4$  (Note factor of conversion  $10^4$  !)
- The moments of inertia of a certain profile are listed on the respective profile page (e.g. 1.09, 1.10, 1.11) and in the tables 1.1D

Type of load		
1		$f = \frac{F \cdot l^3}{3E \cdot J}$
2		$f = \frac{F \cdot l^3 + F_1 \cdot l_1^2 \cdot l + F_2 \cdot l_2^2 \cdot l}{3E \cdot J}$
3		$f = \frac{F \cdot l^3}{8E \cdot J}$
4		$f = \frac{F \cdot l^3}{48E \cdot J}$
5		$f = \frac{F \cdot l^3}{\left(48 + \frac{29m}{l}\right) \cdot E \cdot J}$
6		$f = \frac{5F \cdot l^3}{384E \cdot J}$
7		$f = \frac{F \cdot a^2 \cdot b^2}{3E \cdot J \cdot l}$
8		$f = \frac{F \cdot l^3}{192E \cdot J} \quad 2)$
9		$f = \frac{F \cdot l^3}{384E \cdot J}$

<sup>2)</sup> approximate value

Approximate determination of deflection

To determine the approximation of deflection, use the diagram on this page.

Profile length  $l$  in mm

Determination of deflection

1. Type of load  $F$  in N
2. Profile length  $l$  in mm
3. Move cross point on the diagonal
4. Moment of inertia of the selected profile  $J$  in  $\text{cm}^4$
5. Cross point with the diagonal to be vertically extended to the bottom
6. Deflection  $f$  for the specific "Type of load" in mm

Example

- ①  $F = 2,000$  N
- ②  $l = 1,000$  mm
- ③ Move cross point on the diagonal
- ④  $J = 82.0$   $\text{cm}^4$  for profile 40x80, 6E
- ⑤ Cross point with the diagonal to be vertically extended to the bottom
- ⑥ Deflection for the specific "Type of load" in mm:

Type of load 1:  $f = 9.5$  mm  
 Type of load 4:  $f = 0.6$  mm  
 Type of load 8:  $f = 0.15$  mm

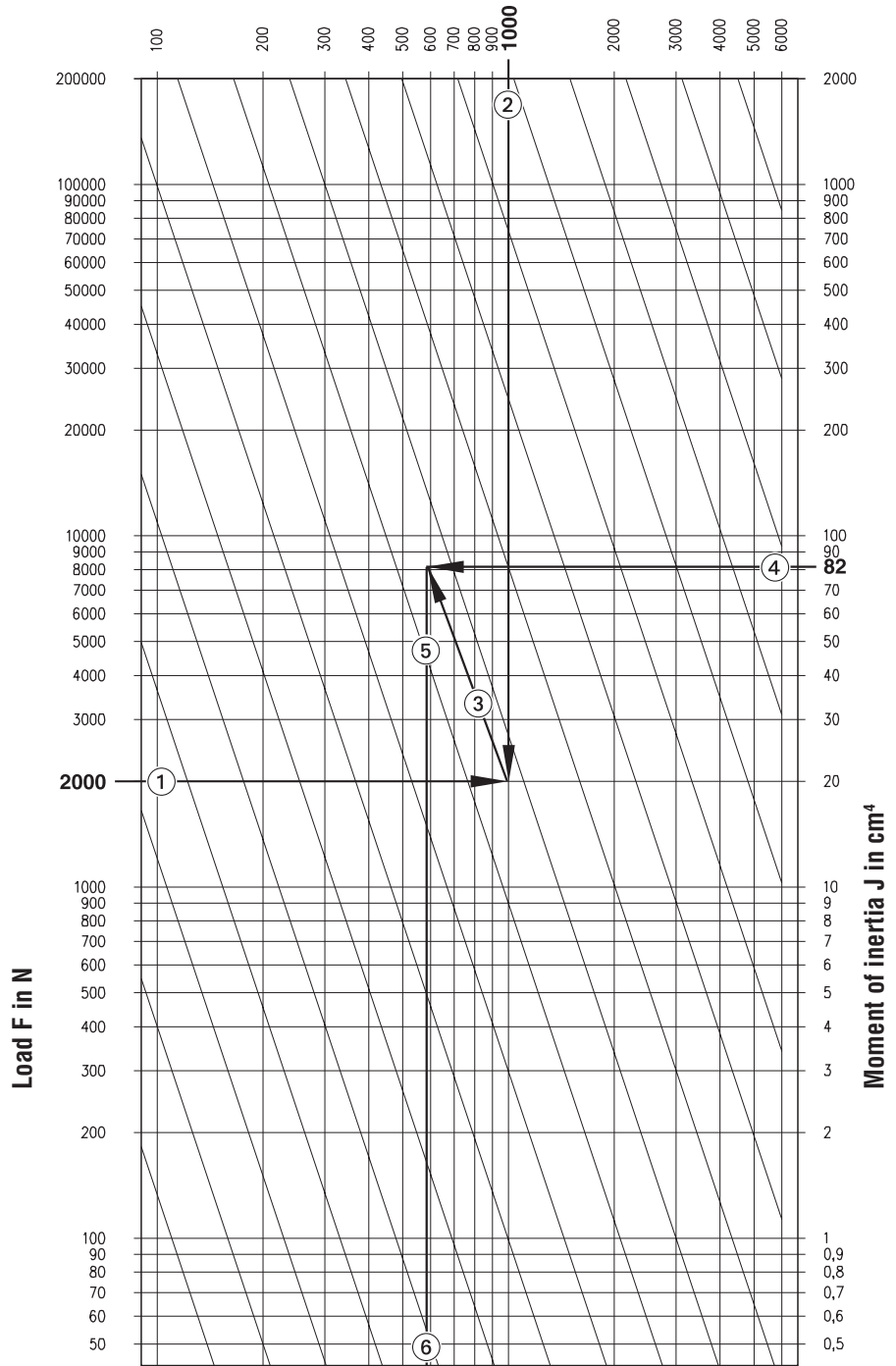

Type of load 1

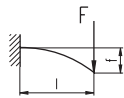

Type of load 4

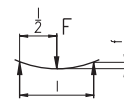

Type of load 8

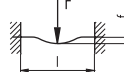



















Deflection  $f$  in mm











Design	PG slot																
16 F	16x40																
E	16x40	16x80	16x160														
20 H					20x20				20x20	20x20	20x20	20x20					
F				20x10											20x30	20x30	
30 F					30x30	30x30	30x30	30x30	30x30	30x30	30x30	30x30					
E4																	30x50
40 E3					40x40	40x40	40x40		40x40	40x40	40x40	40x40		40x60			
45 E4					45x45	45x45	45x45		45x45	45x45	45x45	45x45	45x60				
50 E4					50x50				50x50	50x50	50x50	50x50					
60 E4									60x60		60x60						60x90









Profile	ix <sup>1)</sup>	ly <sup>1)</sup>	Wx <sup>2)</sup>	Wy <sup>2)</sup>	G <sup>3)</sup>	
16x40, 1F, LP	4.4	0.8	2.2	0.8	0.87	12
16x40, 1F, P	5.3	1.0	2.7	1.0	1.0	12
16x40, 1E, LP	4.3	0.8	2.2	0.8	0.75	12
16x40, 1E, P	7.2	1.1	3.6	1.1	1.14	12
16x80, 2E, LP	30.7	1.6	7.7	1.6	1.49	12
16x80, 2E, P	48.3	2.2	12.0	2.2	2.11	12
16x160, 4E, LP	238.3	3.3	29.8	3.3	3.0	12
20x10, 1F, LP	0.1	0.6	0.2	0.5	0.35	15
20x20, 2H, soft, P	0.6	0.6	0.6	0.6	0.52	13
30x30, 2F, soft, P	2.7	2.7	1.6	1.6	0.9	16
2F, soft	2.7	2.7	1.6	1.6	0.9	34
40x40, 2E, soft, LP	6.4	6.4	3.8	3.8	1.2	20
2E, soft, L	6.4	6.4	3.8	3.8	1.2	36
45x45, 2E, soft, LP	11.4	11.4	5.1	5.1	1.6	28
2E, soft	18.8	18.8	7.5	7.5	2.3	42
30x30, 0F, P	4.4	4.4	2.3	2.3	1.3	16
40x40, 0E, LP	12.0	12.0	6.0	6.0	1.8	20
45x45, 0E, LP	15.5	15.5	6.9	6.9	2.2	28
30x30, 1F, LP	3.1	3.1	2.1	2.1	0.9	16
1F, P	4.3	4.0	2.9	2.6	1.2	16
40x40, 1E, LP	8.5	8.1	4.1	4.0	1.3	20
45x45, 1E, LP	14.7	15.5	6.5	6.8	2.1	28
30x30, 2F, Eck	3.7	3.7	2.4	2.4	1.1	34
20x20, 2H, cor., P	1.0	1.0	0.9	0.9	0.68	13
30x30, 2F, cor., LP	3.2	3.2	2.1	2.1	0.9	16
2F, cor., B, P	3.7	3.7	2.4	2.4	1.1	16
2F, cor., L	3.2	3.2	2.1	2.1	0.9	34
2F, cor., B	3.7	3.7	2.4	2.4	1.1	34
40x40, 2E, cor., LP	8.0	8.0	4.0	4.0	1.3	20
2E, cor., L	8.0	8.0	4.0	4.0	1.3	36
2E, cor.	12.3	12.3	6.1	6.1	2.0	36
45x45, 2E, cor., LP	14.7	14.7	6.6	6.6	2.0	28
2E, cor., L	16.5	16.5	6.7	6.7	1.7	42
2E, cor.	28.2	28.2	11.1	11.1	3.2	42
20x20, 2H, LP	1.0	0.8	1.0	0.8	0.58	13
30x30, 2F, LP	3.2	3.2	2.1	2.1	0.9	17
2F, P	3.6	3.9	2.4	2.6	1.1	17
2F, L	3.2	3.2	2.2	2.2	0.9	34
40x40, 2E, LP	8.2	7.5	4.1	3.8	1.3	21
2E, L	8.2	7.5	4.1	3.8	1.3	36
45x45, 2E, LP	14.0	15.5	6.2	6.9	2.0	29
2E, L	17.7	13.6	7.0	5.4	1.6	42
60x60, 2E, LP	35.1	37.7	11.7	12.5	2.9	32
2E, P	55.9	58.5	18.6	19.5	4.3	32

Profile	ix <sup>1)</sup>	ly <sup>1)</sup>	Wx <sup>2)</sup>	Wy <sup>2)</sup>	G <sup>3)</sup>	
20x20, 3H, P	0.9	0.9	0.9	0.9	0.65	13
30x30, 3F, LP	3.3	3.2	2.2	2.2	0.9	17
3F, P	3.5	3.7	2.4	2.4	1.1	17
3F, L	3.3	3.2	2.2	2.2	0.9	34
3F	3.5	3.7	2.4	2.4	1.1	34
40x40, 3E, LP	9.4	10.0	4.7	5.0	1.5	21
3E, L	8.3	8.8	4.1	4.4	1.4	36
3E	12.0	12.3	6.0	6.0	2.0	36
45x45, 3E, LP	14.0	14.7	6.2	6.5	2.1	29
3E, L	18.4	16.0	7.3	5.8	1.9	42
3E	27.3	28.2	11.1	11.1	3.1	42
20x20, 4H, LP	0.8	0.8	0.8	0.8	0.53	14
4H, P	0.9	0.9	0.9	0.9	0.62	14
30x30, 4F, LP	3.3	3.3	2.2	2.2	0.9	17
4F, P	3.5	3.5	2.4	2.4	1.1	17
4F, L	3.3	3.3	2.2	2.2	0.9	35
4F	3.5	3.5	2.4	2.4	1.1	35
40x40, 4E, LP	9.9	9.9	4.9	4.9	1.5	21
4E, P	12.0	12.0	6.0	6.0	2.0	21
4E, L	9.9	9.9	4.9	4.9	1.5	37
4E	12.0	12.0	6.0	6.0	2.0	37
45x45, 4E, LP	13.5	13.5	6.0	6.0	1.9	29
4E, P	15.5	15.5	6.9	6.9	2.1	29
4E, L	13.5	13.5	6.0	6.0	1.9	40
4E	16.8	16.8	7.4	7.4	2.3	40
50x50, 4E, L	19.2	19.2	7.7	7.7	2.2	43
4E	27.3	27.3	11.0	11.0	3.1	43
60x60, 4E, LP	35.5	35.5	11.7	11.7	2.7	32
4E, P	56.0	56.0	18.7	18.7	4.2	32
4E, L	35.5	35.5	11.7	11.7	2.7	44
4E	56.0	56.0	18.7	18.7	4.2	44
45x60, 4E, LP	26.5	16.0	9.0	7.2	2.3	29
4E, P	38.0	23.5	13.0	10.4	3.0	29
4E, L	26.5	16.0	9.0	7.2	2.3	40
4E	38.8	23.5	13.0	10.4	3.0	40
40x60, 0E, LP	27.7	13.1	9.3	6.5	2.1	21
20x30, 1F, LP	2.2	1.4	1.5	1.4	0.7	15
20x30, 2F, LP	2.2	1.5	1.5	1.5	0.74	15
2F, P	2.6	1.9	1.7	1.7	1.0	15
60x90, 6E, L	124.0	54.0	27.5	18.0	4.0	44
6E	193.0	83.0	43.0	27.5	6.0	44
30x50, 4F, L	11.0	4.3	4.8	3.3	1.3	35
4F	16.9	6.6	6.7	4.4	2.0	35

<sup>1)</sup> Ix, Iy = moment of inertia in cm<sup>4</sup>    <sup>2)</sup> Wx, Wy = moment of resistance in cm<sup>3</sup>    <sup>3)</sup> G = weight in kg/m

















Design																		
16 F																		
E																		
20 H			20x40					20x40										
F																		
30 F	30x60							30x60			30x100		30x100	30x100	30x100			30x150
E4											30x100							30x150
40 E3	40x80	40x80		40x80	40x80	40x80	40x80			40x120					40x160	40x160		
45 E4	45x90							45x90										
50 E4								50x100	50x100	50x150								
60 E4																		











Profile	$I_x^{1)}$	$I_y^{1)}$	$W_x^{2)}$	$W_y^{2)}$	$G^{3)}$	$\rightarrow$
 30x60, 0F, P	29.0	7.8	9.6	5.2	2.2	17
40x80, 0E, LP	79.0	21.5	19.7	10.7	3.1	21
45x90, 0E, LP	107.5	30.4	23.9	13.5	3.6	29
0E, P	134.3	36.3	29.8	16.2	4.7	29
 40x80, 3E, cor., LP	73.8	20.5	18.5	10.2	2.8	22
 20x40, 4H, P	7.0	2.0	3.5	2.0	1.3	14
 40x80, 4E, LP	70.7	20.0	17.7	8.9	2.8	22
4E, L	63.2	17.8	15.7	8.9	2.6	37
 40x80, 4E, LBP	74.5	18.3	18.6	9.2	2.8	22
 40x80, 5E, LP	72.2	18.1	18.0	9.0	2.8	22
 20x40, 6H, LP	5.3	1.4	2.6	1.4	0.9	14
6H, P	6.4	1.7	3.2	1.7	1.3	14
30x60, 6F, LP	21.2	5.7	7.0	3.8	1.6	17
6F, P	25.0	7.0	8.3	4.7	2.1	17
6F, L	21.2	5.7	7.0	3.8	1.6	35
6F	32.0	8.0	10.9	5.4	2.1	35
40x80, 6E, LP	62.7	17.7	15.6	8.8	2.5	23
6E, P	82.0	23.4	20.5	11.7	3.8	23
6E, L	62.7	17.0	15.6	8.5	2.6	37
6E	82.0	23.4	20.5	11.7	3.8	37
45x90, 6E, LP	98.0	27.5	21.8	12.2	3.3	30
6E, P	126.0	34.0	28.0	15.0	4.4	30
6E, L	98.0	27.5	21.8	12.2	3.3	40
6E	126.0	34.0	28.0	15.0	4.4	40
50x100, 6E, L	138.0	37.0	27.5	14.5	3.5	43
6E	202.0	57.2	40.4	22.8	5.9	43
 50x100, 8E, L	137.0	40.0	27.5	16.0	4.0	43
50x100, 8E	200.0	53.3	39.9	21.3	6.0	43
 40x120, 8E, L	194.0	26.0	33.0	13.0	3.7	37
50x150, 8E	628.0	83.0	83.0	33.0	8.1	43
 30x100, 5F, L	83.2	9.5	16.6	6.3	2.2	35



Profile	$I_x^{1)}$	$I_y^{1)}$	$W_x^{2)}$	$W_y^{2)}$	$G^{3)}$	$\rightarrow$
 30x100, 5E, 2F, P	108.9	12.4	21.7	8.3	3.5	18
 30x100, 8F, P	115.0	11.6	22.9	7.7	3.4	18
 30x100, 9F, P	130.6	11.9	25.9	7.9	3.6	18
 30x100, 10F, P	127.0	11.9	25.4	7.9	3.6	19
 40x160, 6E, LP	450.4	36.3	56.3	18.1	5.0	23
 40x160, 10E, L	478.0	36.6	60.0	18.3	5.6	37
 30x150, 8F, P	340.0	16.0	45.0	11.0	4.1	19
 30x150, 8E, P	481.0	25.1	64.1	16.7	7.9	19

<sup>1)</sup>  $I_x, I_y$  = moment of inertia in  $cm^4$     <sup>2)</sup>  $W_x, W_y$  = moment of resistance in  $cm^3$     <sup>3)</sup>  $G$  = weight in  $kg/m$



Design																
PG slot																
16	F															
	E															
20	H					40x40										
	F															
30	F	60x60				60x60		60x60								
	E4															
40	E3	80x80	80x80	80x80	80x80	80x80	80x80	80x80	80x120	80x160	80x160	80x160		120x120		
45	E4					90x90	90x90									
50	E4					100x100	100x100					100x200	100x300			
60	E4															

	Profile	$I_x^{1)}$	$I_y^{1)}$	$W_x^{2)}$	$W_y^{2)}$	$G^{3)}$	$\rightarrow$
	60x60, 0F, P	58.2	58.2	15.5	15.5	4.0	19
	80x80, 0E, LP	135.0	135.0	33.5	33.5	4.7	23
	80x80, 4E, cor., LP	128.0	128.0	32.0	32.0	4.5	23
	80x80, 6E, LP	121.3	116.0	30.3	29.0	4.2	23
	80x80, 7E, P	173.0	160.0	43.3	40.0	7.6	23
	40x40, 8H, LP	10.0	10.0	5.0	5.0	1.5	14
	60x60, 8F, L	38.7	38.7	12.9	12.9	2.6	35
	80x80, 8E, LP	114.0	114.0	28.4	28.4	4.1	24
	8E, P	166.0	166.0	41.4	41.4	5.9	24
	8E, L	111.0	111.0	28.0	28.0	3.7	38
	8E	166.0	166.0	41.4	41.4	5.9	38
	90x90, 8E, LP	190.5	190.5	42.3	42.3	5.6	30
	8E, L	183.0	183.0	40.7	40.7	5.3	40
	100x100, 8E	411.0	411.0	82.0	82.0	9.7	43
	80x80, 8E, LB	115.0	115.0	29.0	29.0	4.5	38
	90x90, 8E, P	282.0	282.0	63.0	63.0	9.5	30
	8E	282.0	282.0	63.0	63.0	9.5	40
	100x100, 8E, L	284.0	284.0	50.8	50.8	6.2	43
	60x60, 8F, angle	35.2	35.2	9.9	9.9	2.8	35
	80x80, 8E, angle	120.0	120.0	23.8	23.8	6.3	38
	80x120, 10E, P	449.9	217.8	72.6	54.4	8.6	24
	80x160, 8E, P	944.0	183.0	118.0	45.8	7.9	24
	80x160, 8E, LP	828.0	259.0	104.0	65.0	8.6	24
	80x160, 12E, P	883.0	269.0	110.0	67.3	9.4	24
	12E, L	801.0	235.0	100.0	59.0	8.8	38
	12E	880.0	268.0	110.0	67.0	9.4	38
	100x200, 12E, P	2,450.0	760.0	250.0	152.0	17.2	29

	Profile	$I_x^{1)}$	$I_y^{1)}$	$W_x^{2)}$	$W_y^{2)}$	$G^{3)}$	$\rightarrow$
	100x300, 16E, P	8,320.0	1,170.0	555.0	234.0	25.6	31
	120x120, 12E, P	624.0	624.0	104.0	104.0	10.6	25

<sup>1)</sup>  $I_x, I_y$  = moment of inertia in  $cm^4$     <sup>2)</sup>  $W_x, W_y$  = moment of resistance in  $cm^3$     <sup>3)</sup>  $G$  = weight in  $kg/m$



Design	PG slot															
16	F															
	E															
20	H															
	F															
30	F											30 hexag.	30 octag.			
	E4															
40	E3	40x40	80x80	80x80	40x30°	40x45°	40x60°	40x90°				40 hexag.	40 octag.			
45	E4															
50	E4								48 round	48 round	48 round					
60	E4															

Profile	$I_x^{1)}$	$I_y^{1)}$	$W_x^{2)}$	$W_y^{2)}$	$G^{3)}$	
40x40, 2E, 45°, LP	7.3	7.3	3.9	3.9	1.4	26
80x80, 3E, 45°, LP	106.0	106.0	26.5	26.5	4.3	26
80x80, 7E, 45°, LP	99.3	99.3	24.8	24.8	4.0	26
40, round 30°, 2F, L	6.0	4.8	3.0	2.4	1.2	39
40, round 45°, 2E, LP	14.5	8.0	4.9	3.7	1.6	26
40, round 45°, 2E, L	14.5	8.0	4.9	3.7	1.6	39
40, round 60°, 2E, L	30.0	10.5	7.6	4.6	1.9	39

Profile	$I_x^{1)}$	$I_y^{1)}$	$W_x^{2)}$	$W_y^{2)}$	$G^{3)}$	
40, round 90°, 2E, LP	89.0	89.0	16.0	16.0	3.0	26
40, round 90°, 2E, L	89.0	89.0	16.0	16.0	3.0	39
48, round, 1E, P	12.5	12.9	4.9	5.4	1.8	33
48, round, 2E, cor., P	12.0	12.0	5.0	5.0	2.0	33
48, round, 2E, P	12.5	13.5	5.1	5.9	2.0	33
30, hexag., 6F, P	32.0	32.0	9.8	9.8	2.8	33
40, hexag., 6E, P	83.0	83.0	21.0	21.0	4.4	33
30, octag., 8F, P	84.0	84.0	21.0	21.0	3.9	33
40, octag., 8E, P	233.0	233.0	44.0	44.0	6.5	33

Design	PG slot															
16	F															
	E															
20	H															
	F															
30	F	30x30			30x45											
	E4															
40	E3	40x40	40x40	40x40	40x60	40x60	60x80	60x80								
45	E4															
50	E4															
60	E4															

Profile	$I_x^{1)}$	$I_y^{1)}$	$W_x^{2)}$	$W_y^{2)}$	$G^{3)}$	
30x30, 2F, WG, LP	7.5	2.6	3.2	2.1	0.86	46
40x40, 2E, WG, LP	7.5	7.5	8.2	4.1	1.34	46
40x40, 2E, c., P., LP	4	10.3	10.3	5.2	1.80	45
40x40, 3E, P., LP	4	10.2	8.7	4.3	1.65	45
30x45, 2F, WG, LP	7.5	4.3	7.4	3.3	1.15	46
40x60, 2E, WG, LP	12.0	12.0	22.7	7.6	1.95	46

Profile	$I_x^{1)}$	$I_y^{1)}$	$W_x^{2)}$	$W_y^{2)}$	$G^{3)}$		
40x60, 3E, P., LP	4	14.8	26.3	7.4	8.8	2.4	45
60x80, 5E, P., LP	4	100.4	50.4	25.1	16.8	3.8	45
60x80, 6E, P., LP	4	85.8	50.8	21.5	16.9	3.7	45

<sup>1)</sup>  $I_x, I_y$  = moment of inertia in  $cm^4$     <sup>2)</sup>  $W_x, W_y$  = moment of resistance in  $cm^3$     <sup>3)</sup>  $G$  = weight in  $kg/m$

**Profile combinations**



With the MayTec Connector System it is possible to make a multitude of form-matching and stable profile combinations.

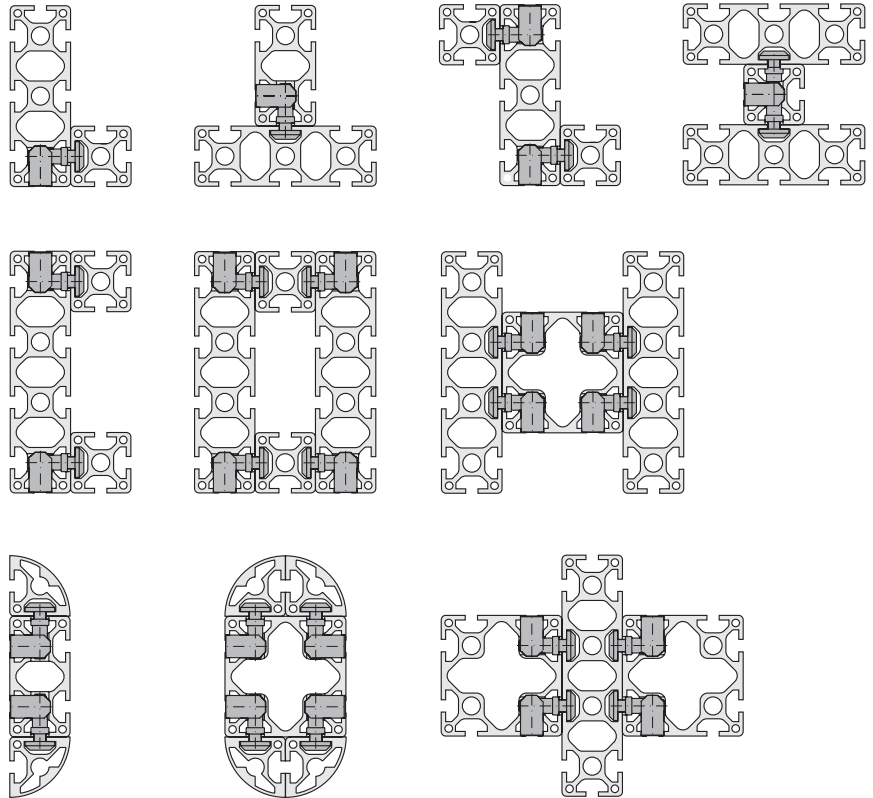

**Special slits**

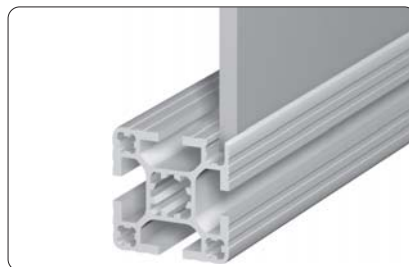

Panel elements can be set in the profile flush to the outer edge for form-matching design. The slits needed for that can be made in nearly all profiles.

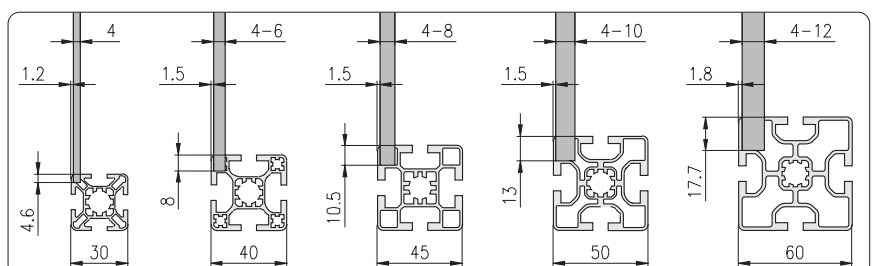

Slot plates

F-slot

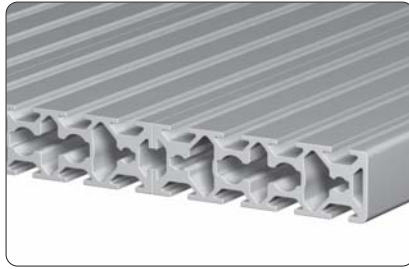

F-slot, slot distance 25 mm



F-slot, slot distance 50 mm

**Application**

Profiles to construct slot plates of any required size

E-slot



E-slot, slot distance 25 mm (on top),  
100 mm (on bottom)



E-slot, slot distance 50 mm

**Slot plates F-slot**  
Slot distance 25 mm

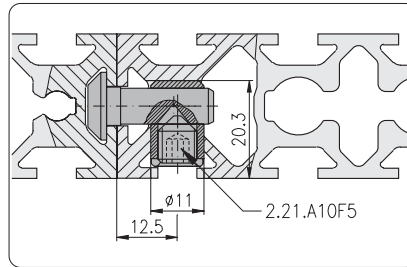
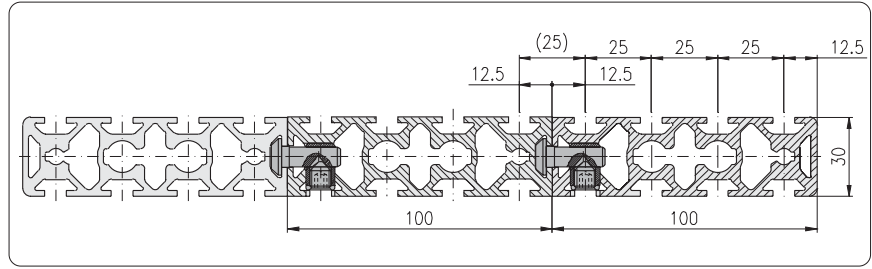

**Single parts**  
connector 2.21.10F5

Drill dimensions

**Profile 30×100, 9F, plain**

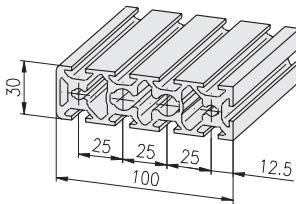

Description	Weight	Article-No.
Profile 30×100, 9F, plain	bar 6 m 3.6 kg/m	1.11.030100.94P.60

**Profile 30×100, 10F, plain**

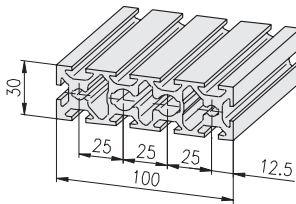

Description	Weight	Article-No.
Profile 30×100, 10F, plain	bar 6 m 3.6 kg/m	1.11.030100.104P.60

**Slot plates F-slot**  
Slot distance 50 mm

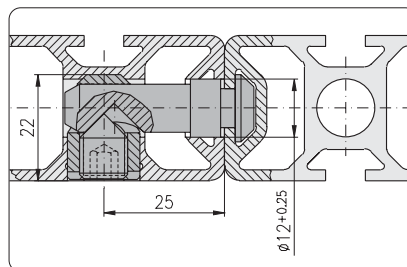
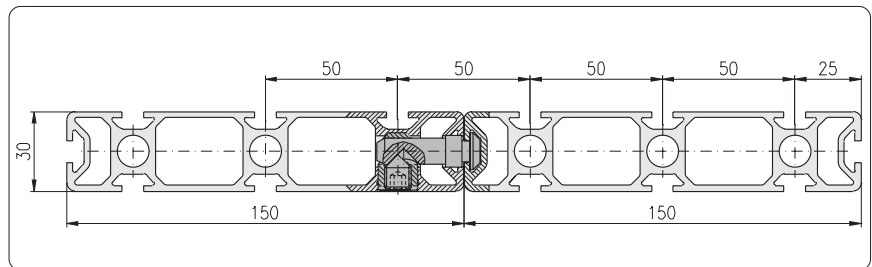

**Single parts**  
connector 1.21.3/5F5

Drill dimensions

**Profile 30×150, 8F, plain**

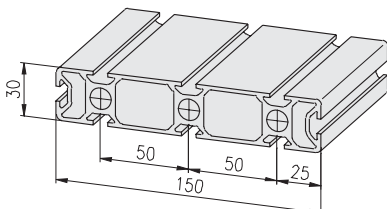

Description	Weight	Article-No.
Profile 30×150, 8F, plain	bar 6 m 4.1 kg/m	1.11.030150.85P.60

machining data Profile machining 1.1A

**Slot plates E-slot**  
Slot distance 25 mm

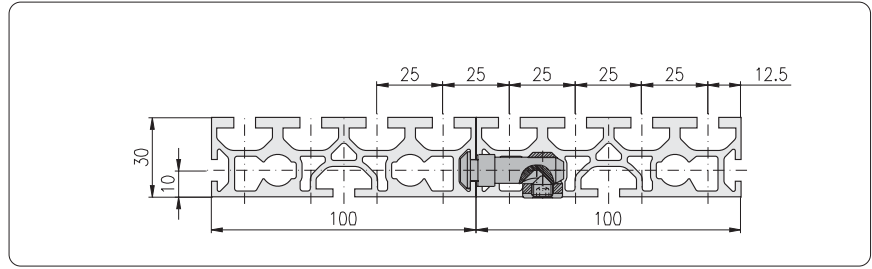

**Profile 30×100, 5E, 2F, plain**

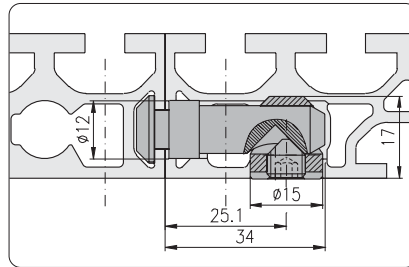
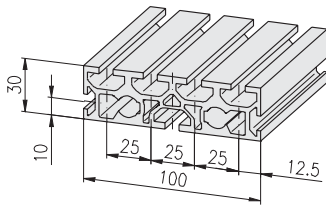

**Single parts**  
connector 1.21.2/5F5

Drill dimensions

Description	Weight	Article-No.
Profile 30×100, 5E, 2F, plain	bar 6 m 3.5 kg/m	1.11.030100.74P.60

**Slot plates E-slot**  
Slot distance 50 mm

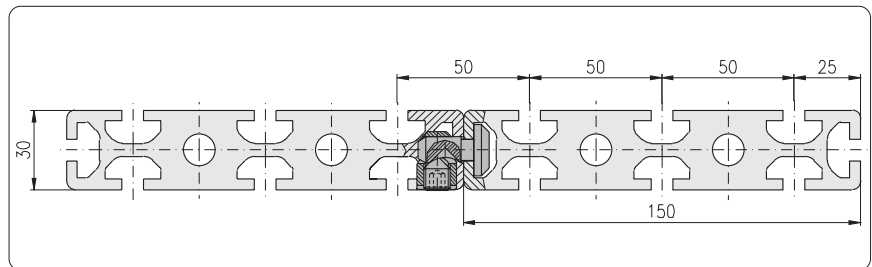

**Profile 30×150, 8E, plain**

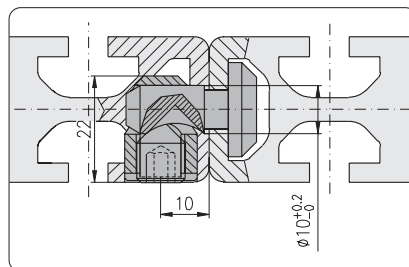
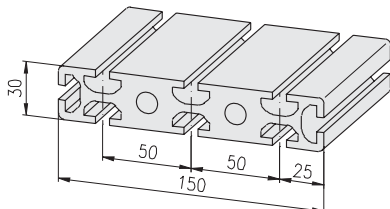

**Single parts**  
anchor 1.21.A2E5  
cross bushing 1.21.B34

Drill dimensions

Description	Weight	Article-No.
Profile 30×150, 8E, plain	bar 6 m 7.9 kg/m	1.11.030150.84P.60

machining data ↗ Profile machining 1.1A

Hand rail



**Application**

Hand rail for balustrades on stairs and platforms

**Comments**

Angled joints: 0 deg. to 90 deg.  
Incline: 0 deg. to 45 deg.

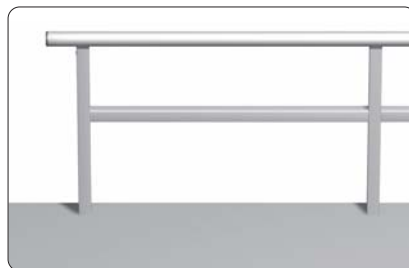
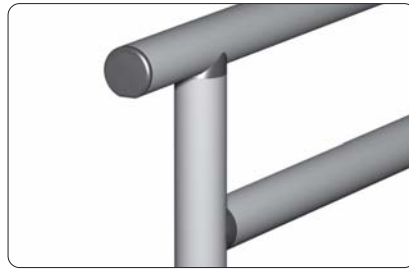

Hand rail straight



Hand rail angled



Hand rail tilted



Hand rail tilted and angled

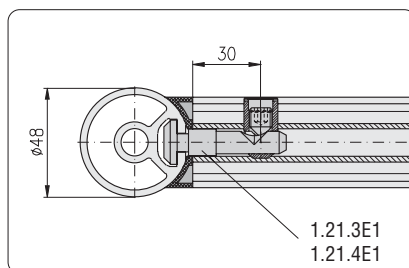

Working dimensions for hand rail straight with radius compensation

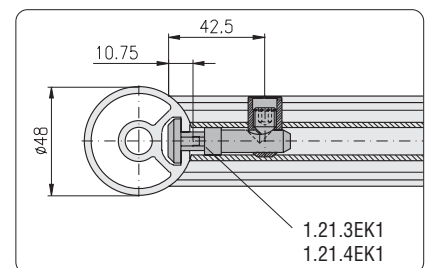

Working dimensions for hand rail straight, tilted and/or angled without radius compensation (milled)

**U-Profile 40**



**Application**

For the construction of height adjustable frames on 40x40 and 40x80 profile bases

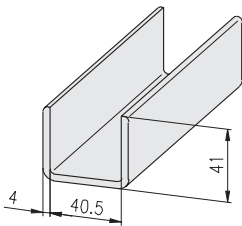
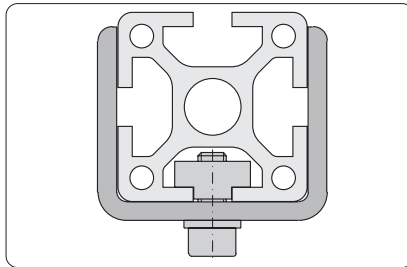

Description	Weight	Article-No.
U-Profile 40 bar 6 m	1.35 kg/m	1.19.14440.60



**Profiles for cable guide**

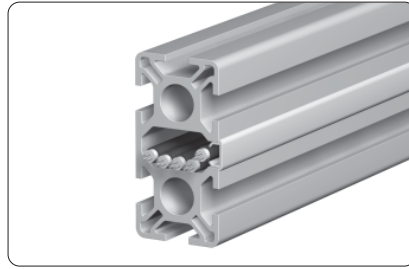

**Application**

For running cables or pneumatic hoses.  
All chamber profiles can be delivered with open slots.

Cover is carried out by cover profiles:

Cover profile PVC 1.41.11□

Cover profile ALU 1.41.121

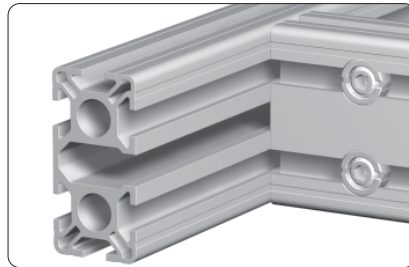

Application of cross braces to stabilize slotted profiles

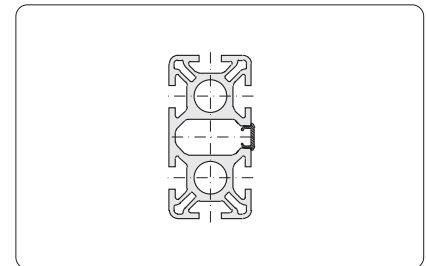
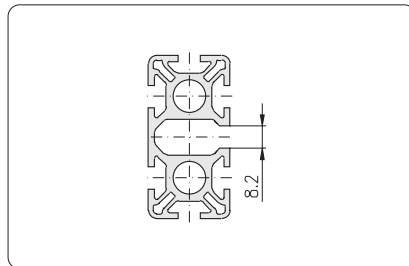

- 16
- 20
- 30
- 40
- 45
- 50
- 60

**Comments**

Profiles for cable guide see list at profile pre-cut lid

**Order details**

**Description**

Profile □□□□□□ for cable guide, slotted 8 mm

**Article-No.**

1.12.□□□□□□.□□

**Order example**

**Order request**

Profile 40×80 mm, 6 E-slots, 8 mm slotted for cable guide, length 4.5 m

**Order**

Profile 40×80, 6E for cable guide, slotted 8 mm

1.12.040080.65-F00F00/4500



**Profiles for cable guide**  
**Slot distance 30**

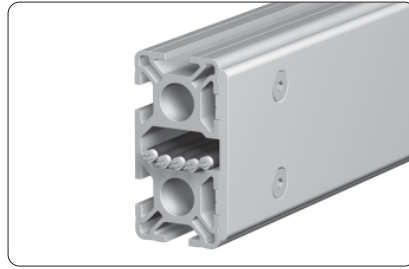

**Application**

For running cables or pneumatic hoses. All chamber profiles can be delivered with open slots.

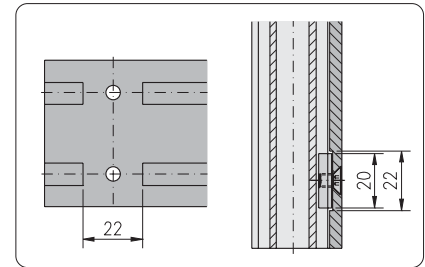
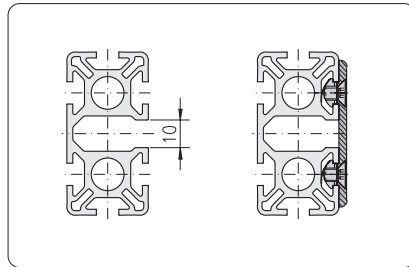

Milled section on the pre-cut lid for fastening with T-Nut in F-slot

Profiles for cable guide, slot distance 30				
Profile	light, plain	heavy, plain	light	heavy
30x60	6F LP	0F P 6F P	6F L	6F
60x60		0F P	8F L	8F angle

**Order details**

**Description**

Profile □□□□□□ for cable guide, slotted 10 mm

**Article-No.**

1.13.□□□□□□.□□

**Order example**

**Order request**

Profile 30x60 mm, 6 F-slots, 10 mm slotted for cable guide, length 4.5 m

**Order**

Profile 30x60, 6F for cable guide, slotted 10 mm

1.13.030060.65-A00A00/4500

**Profile pre-cut lid 30**

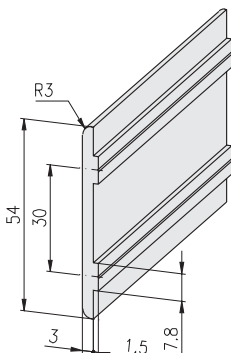

**Single parts**

- countersunk screw DIN 7991, M5x8 0.63.D07991.05008
- threaded plate F, M5 1.31.FM5
- T-Nut for subsequent insertion F, M5 1.324.FM5

**Description**

Profile pre-cut lid 30

**Weight**

0.49 kg/m

**Article-No.**

1.19.110130

machining data Profile machining 1.1A

**Profiles for cable guide**  
**Slot distance 40**

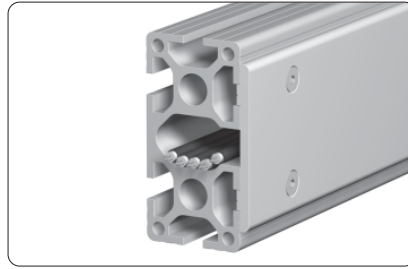

**Application**

For running cables or pneumatic hoses. All chamber profiles can be delivered with open slots.

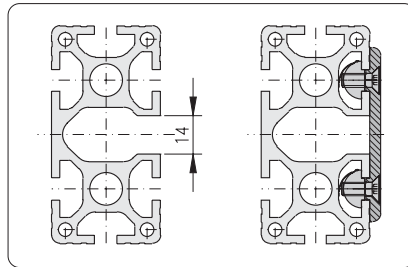

Profiles for cable guide, slot distance 40												
Profile	light, plain					heavy, P	light		heavy			
40x80												
80x80												

**Order details**

**Description**

Profile □□□□□□ for cable guide, slotted 14 mm

**Article-No.**

1.13.□□□□□□.□□

**Order example**

**Order request**

Profile 80x80 mm, 8 E-slots, 14 mm slotted for cable guide, length 4.5 m

**Order**

Profile 80x80, 8E for cable guide, slotted 14 mm

1.13.080080.83-L00L00/4500

**Profile pre-cut lid 40**

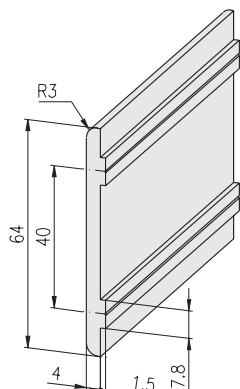

**Single parts**

- countersunk screw DIN 7991, M6x14 0.63.D07991.06014
- threaded plate E, M6 1.31.EM6
- T-Nut for subsequent insertion E, M6 1.324.EM6

**Description**

Profile pre-cut lid 40

**Weight**

0.74 kg/m

**Article-No.**

1.19.110140

machining data Profile machining 1.1A

**Profiles for cable guide**  
Slot distance 50

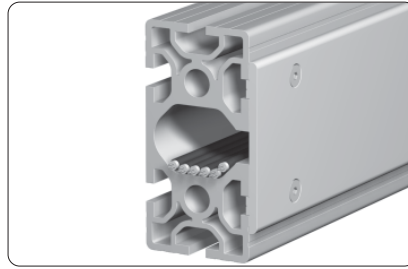

**Application**

For running cables or pneumatic hoses. All chamber profiles can be delivered with open slots.

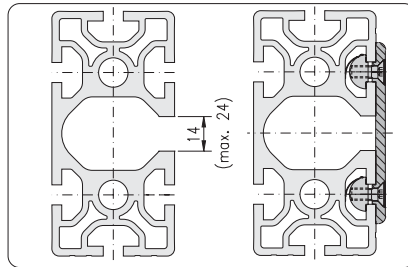

Profiles for cable guide, slot distance 50				light	heavy
heavy, plain					
30x100	30x150	100x200	100x300	50x100	100x100
8F P	8F P	12E P	16E P	6E L	8E L
				50x100	50x150
				6E	8E
					100x100
					8E

**Order details**

**Description**

Profile □□□□□□ for cable guide, slotted 14 mm

**Article-No.**

1.13.□□□□□□.□□

**Order example**

**Order request**

Profile 50x100 mm, 6 E-slots, 14 mm slotted for cable guide, length 4.5 m

**Order**

Profile 50x100, 6E for cable guide, slotted 14 mm

1.13.050100.65-F00F00/4500

**Profile pre-cut lid 50**

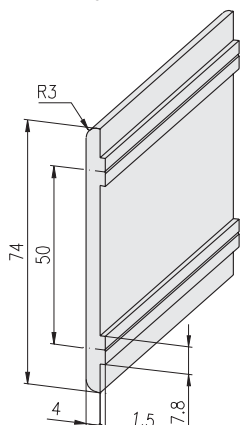

**Single parts**

**F-slot**

- countersunk screw DIN 7991, M5x8 0.63.D07991.05008
- threaded plate F, M5 1.31.FM5
- T-Nut for subsequent insertion F, M5 1.324.FM5

**E-slot**

- countersunk screw DIN 7991, M6x14 0.63.D07991.06014
- threaded plate E, M6 1.31.EM6
- T-Nut for subsequent insertion E, M6 1.324.EM6

**Description**

Profile pre-cut lid 50

**Weight**

0.85 kg/m

**Article-No.**

1.19.110150

machining data ↗ Profile machining 1.1A

## Bent profiles

For bent profiles the following data are needed:

- Profile (current conditions see table below)
- Position of profile ↗ 59
- Bending radius
- Bending direction ↗ 61
- Accuracy to size for profile elements and for profile functions

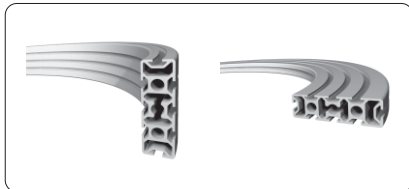

Position of profile



Function 'T- Nut'													Function 'threaded plate'													Function 'connector'																									
position of slot(s)													position of slot(s)													position of slot(s)													position of core hole(s)												
A	B	C	D	E	F	G	H	I	K	L	M	A	B	C	D	E	F	G	H	I	K	L	M	A	B	C	D	E	F	G	H	I	K	L	M	a	b	c	d	e	f	g	h								

The marking of the slots and core holes takes place in accordance with the marking for 'the profile machining' ↗ 1.1A

Article-No.	PG	Profile	min. inside-Ø
1.10.016040.14P	16	16×40, 1F, P	400
1.10.016040.14LP		16×40, 1F, LP	400
1.10.016040.14P		16×40, 1F, P	400
1.10.020020.21P	20	20×20, 2H, soft, P	700
1.10.020020.22P		20×20, 2H, cor., P	700
1.10.020020.23LP		20×20, 2H, LP	700
1.10.020020.33P		20×20, 3H, P	700
1.10.020020.43LP		20×20, 4H, LP	700
1.10.020020.43P		20×20, 4H, P	700
1.11.020010.14LP		20×10, 1F, LP	400
1.11.020030.14LP		20×30, 1F, LP	700
1.11.020030.24LP		20×30, 2F, LP	700
1.11.020030.24P		20×30, 2F, P	700
1.11.030030.03P	30	30×30, 0F, P	700
1.11.030030.13LP		30×30, 1F, LP	700
1.11.030030.13P		30×30, 1F, P	700
1.11.030030.22		30×30, 2F, cor.	700
1.11.030030.22B		30×30, 2F, cor., B	700
1.11.030030.22BP		30×30, 2F, cor., B, P	700
1.11.030030.22L		30×30, 2F, cor., L	700
1.11.030030.22LP		30×30, 2F, cor., LP	700
1.11.030030.23L		30×30, 2F, L	700
1.11.030030.23LP		30×30, 2F, LP	700
1.11.030030.23P		30×30, 2F, P	700
1.11.030030.33		30×30, 3F	700
1.11.030030.33L		30×30, 3F, L	700
1.11.030030.33LP		30×30, 3F, LP	700
1.11.030030.33P		30×30, 3F, P	700
1.11.030030.43		30×30, 4F	700
1.11.030030.43L		30×30, 4F, L	700
1.11.030030.43LP		30×30, 4F, LP	700
1.11.030030.43P		30×30, 4F, P	700
1.11.030050.44		30×50, 4F	700
1.11.030050.44L		30×50, 4F, L	700
1.11.030060.04P		30×60, 0F, P	700
1.11.030060.64L		30×60, 6F, L	700

Article-No.	PG	Profile	min. inside-Ø
1.11.030060.64LP		30×60, 6F, LP	700
1.11.030060.65	30	30×60, 6F	700
1.11.030060.65		30×60, 6F	700
1.11.030100.54L		30×100, 5F, L	700
1.11.030100.74P		30×100, 5E, 2F, P	700
1.11.030100.84P		30×100, 8F, P	700
1.11.030100.94P		30×100, 9F, P	700
1.11.030100.104P		30×100, 10F, P	700
1.11.040040.03LP	40	40×40, 0E, LP	700
1.11.040040.13LP		40×40, 1E, LP	700
1.11.040040.22		40×40, 2E, cor.	700
1.11.040040.22L		40×40, 2E, cor., L	700
1.11.040040.22LP		40×40, 2E, cor., LP	700
1.11.040040.23L		40×40, 2E, L	700
1.11.040040.23LP		40×40, 2E, LP	700
1.11.040040.33		40×40, 3E	700
1.11.040040.33L		40×40, 3E, L	700
1.11.040040.33LP		40×40, 3E, LP	700
1.11.040040.43		40×40, 4E	700
1.11.040040.43L		40×40, 4E, L	700
1.11.040040.43LP		40×40, 4E, LP	700
1.11.040040.43P		40×40, 4E, P	700
1.11.040060.04LP		40×60, 0E, LP	700
1.11.040080.04LP		40×80, 0E, LP	700
1.11.040080.44L		40×80, 4E, L	700
1.11.040080.64L		40×80, 6E, L	700
1.11.040080.65		40×80, 6E	700
1.11.040080.32LP		40×80, 3E, cor., LP	700
1.11.040080.44LP		40×80, 4E, LP	700
1.11.040080.44LBP		40×80, 4E, LBP	700
1.11.040080.54LP		40×80, 5E, LP	700
1.11.040080.64LP		40×80, 6E, LP	700
1.11.040080.64P		40×80, 6E, P	700
1.11.048R00.10P		48, round, 1E, P	1.500
1.11.048R00.20P		48, round, 2E, P	1.500
1.11.048R00.22P		48, round, 2E, cor., P	1.500

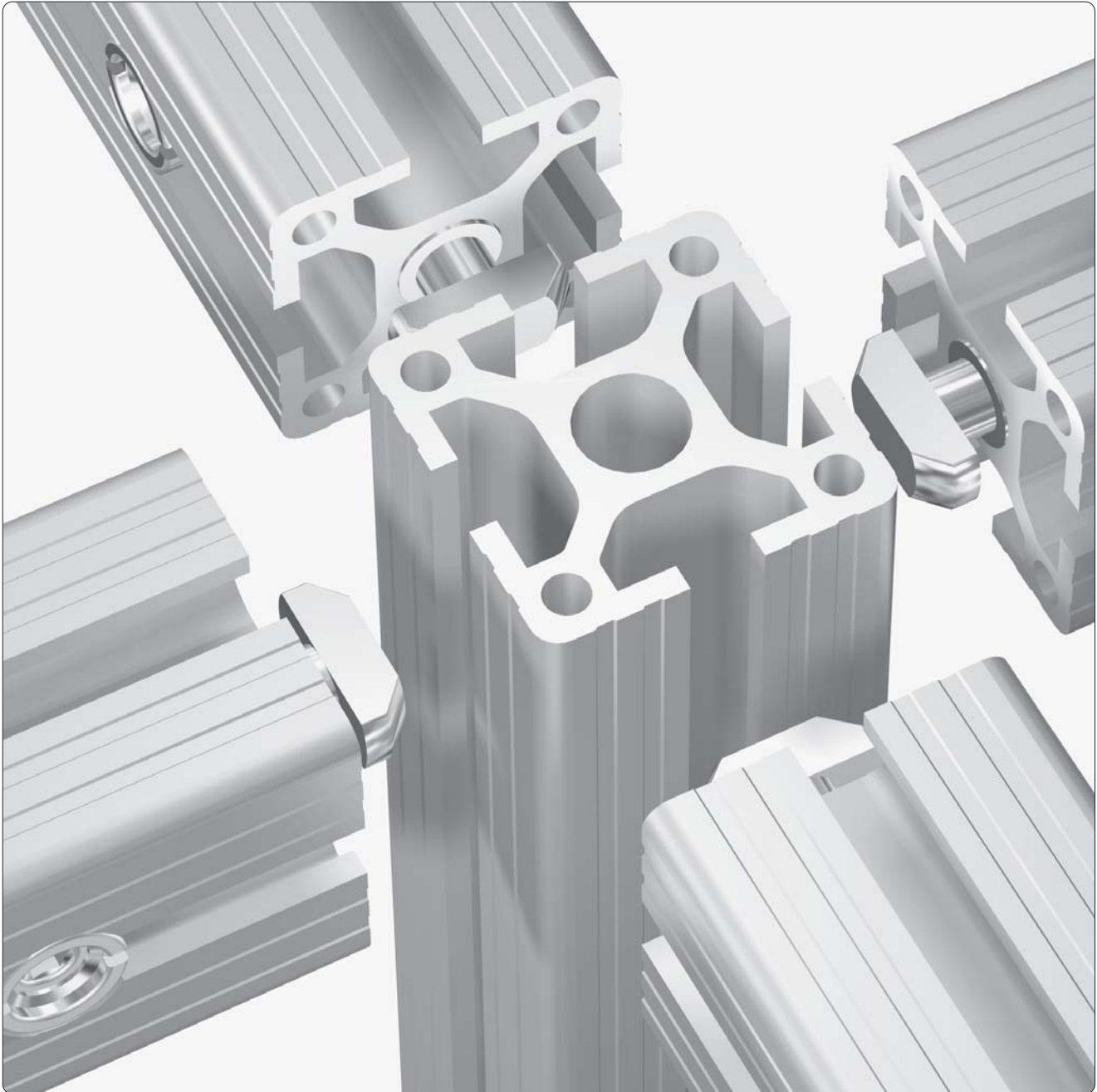

2

<b>Simple</b>	<b>The proven connection system!</b>	<b>The connection allows:</b>
<b>Quick</b>	The MayTec quick-connection system allows combination of all MayTec profiles in any way imaginable.	<ul style="list-style-type: none"> <li>• easy machining</li> <li>• quick assembly</li> <li>• innumerable (dis)assemblies</li> </ul>
<b>Economical</b>	It carries same stability out after all four sides.	<b>The connection system is:</b>
<b>Functional</b>		<ul style="list-style-type: none"> <li>• complete</li> <li>• stable</li> <li>• functional</li> </ul>

<b>Vibration proof</b>	The different direction angles of lead of thread and clamping cone prevent the loosening of the connection by vibration.	
------------------------	--	--



**Stability S-Class**

**MayTec  
Universal-Connector**

**18,000N**  
working load

**Vibration  
proof**

**MayTec connector with square head**

The MayTec connector with square head offers the highest load bearing capacity.

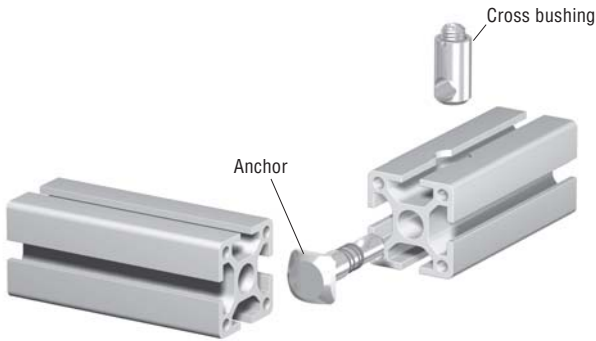

**MayTec universal-connector**

The MayTec universal-connector allows:

- any desired position of profiles
- only one type for 0° and 90° position of cross bushing
- simple determination of the connector type
- minimisation of stock keeping

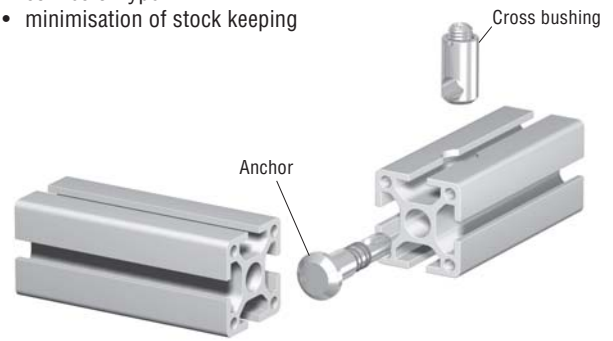

**MayTec standard-connector**

The MayTec standard-connector allows subsequent front-sided mounting or dismounting in any location.

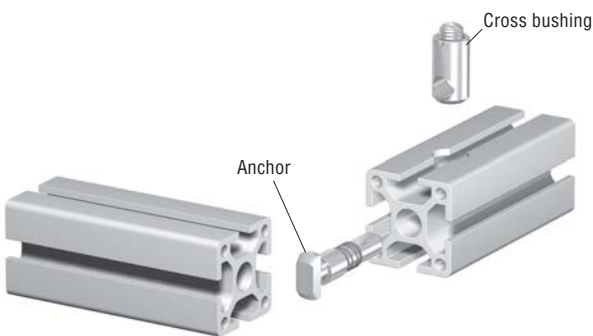

**MayTec ground-connector for potential equalisation**

The MayTec ground-connector allows potential equalisation between two profiles. When the connector is tightened, the serration at the rear of the anchor head penetrates the anodised profile coating and thus provides an electrical contact.

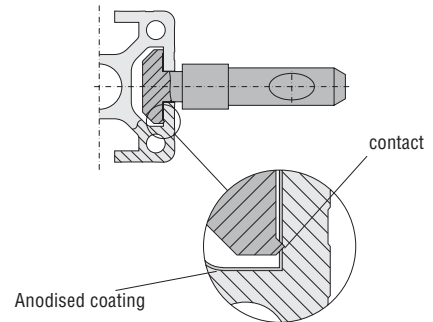

Deliverable types ↗ *Connectors 1.2A*  
Ground connections ↗ *1.70*

**MayTec screw-type connector**

The MayTec screw-type connector allows connection to profiles by means of T-Nuts.

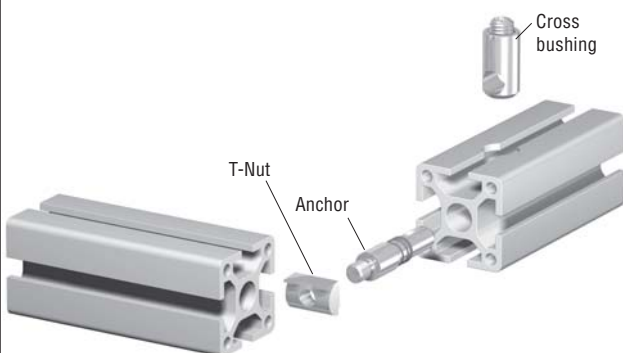

**MayTec screw-type connector**

The MayTec screw-type connector allows connection to threaded holes in plates.

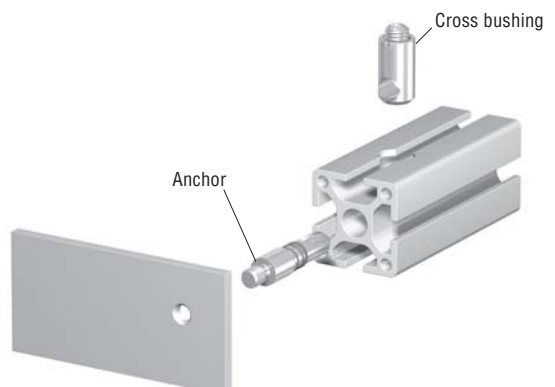

**The MayTec Connector System**

- mounting of connector in core hole
- with machining

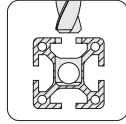

Cross bushing bore

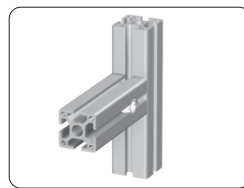
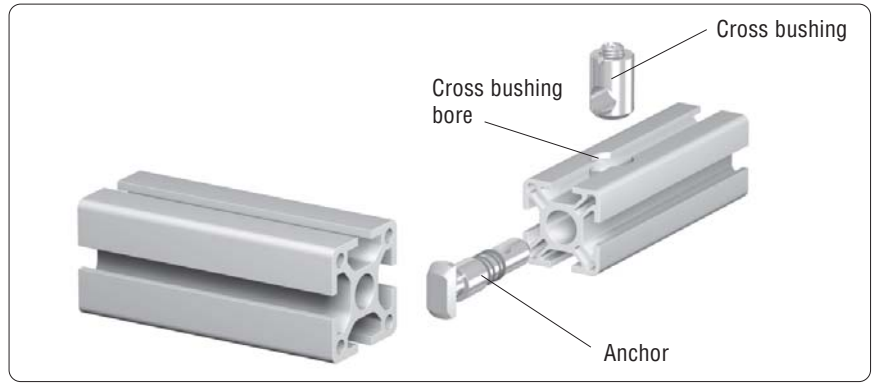

Standard ↗ 91, 93

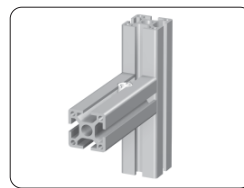

Screw-type ↗ 92, 97

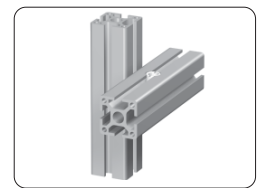

Parallel ↗ 91, 95

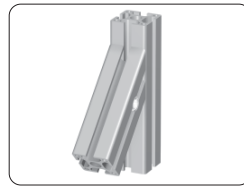

Oblique ↗ 91, 93

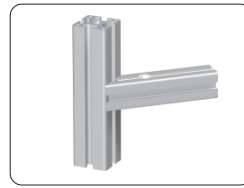

Oblique-cross ↗ 94

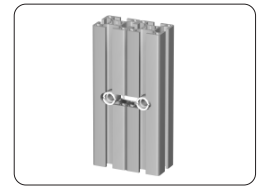

Extension / Parallel ↗ 107

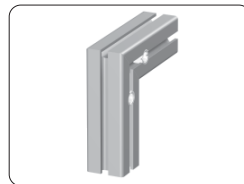

Miter ↗ 91, 96



Shifter ↗ 96

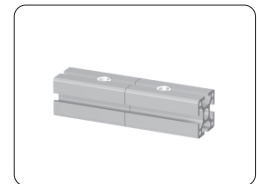

Extension ↗ 91, 95

**Anti-twist devices**



with retaining plate ↗ 128



with T-Nut ↗ 129-130

**Clamping lever for connectors**



Clamping lever ↗ 131



**The MayTec Connector System**

- mounting of connector in slot
- with machining

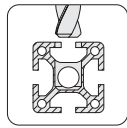

Cross bushing bore

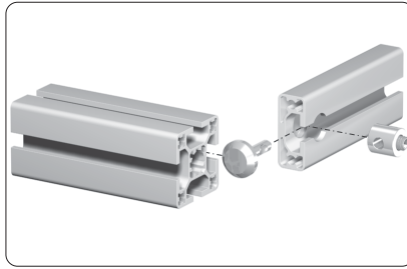

SE-Connector ↗ 109

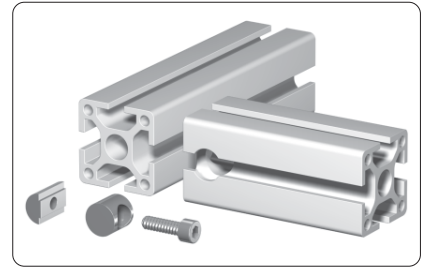

ST-Connector ↗ 110-111

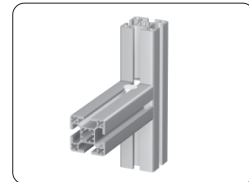
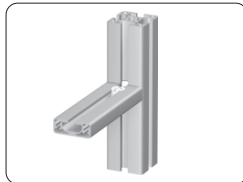

**Screw-type connections**

- with machining

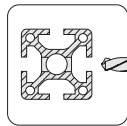
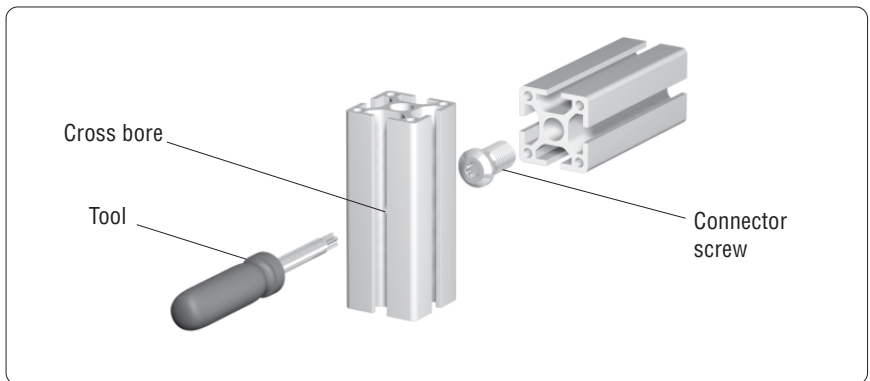

Cross bore

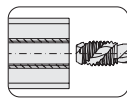

Thread

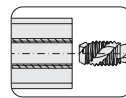

Thread

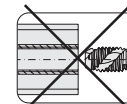

Thread

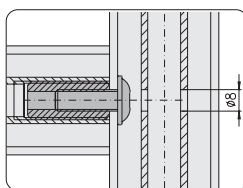

Threaded insert with lens head screw  
↗ 1.35

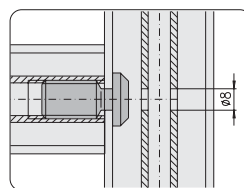

Connector screw  
↗ 98

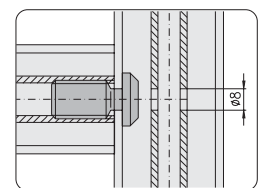

Connector screw, self-cutting  
↗ 98, 112

**Clamping connections**

- with machining

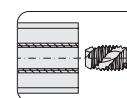
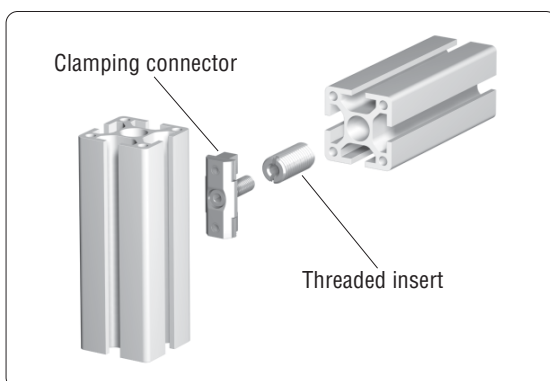

Thread

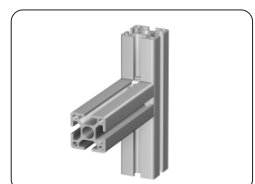

Clamping connector  
↗ 117

**Bayonet type connections**  
 • without machining

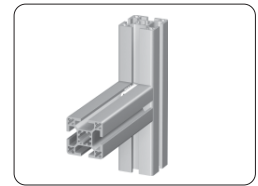
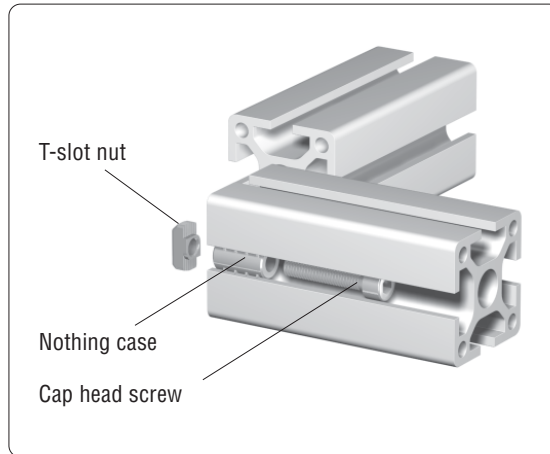

Standard ↗ 113-114



Extension ↗ 115

**Cross connections**  
 • without machining

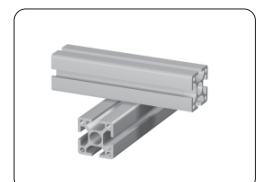
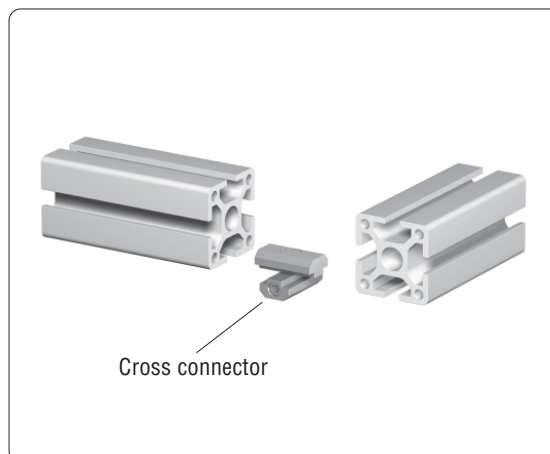

Cross connector ↗ 116

**Angle connections**  
 • without machining

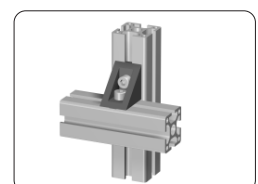
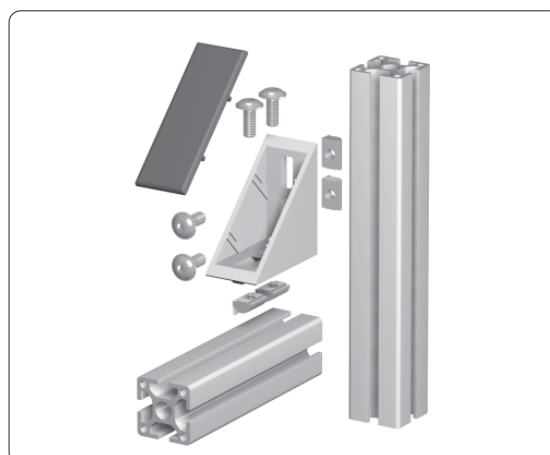

Angle PA ↗ 1.46

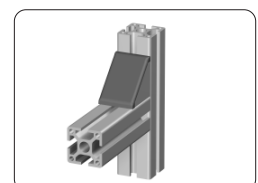

Angle GD-Zn, GD-Al  
 ↗ 1.46

**Manufacture a connection**

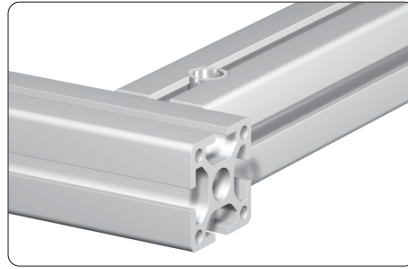

**Example**

Connection of two profiles 40x40 with one standard connector

**1. Connector selection**

➤ 1.2, Connector selection

**2. Profile machining**

➤ 1.1A, Profile machining

➤ 1.99, Tools

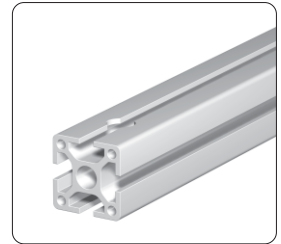
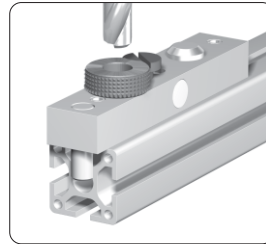
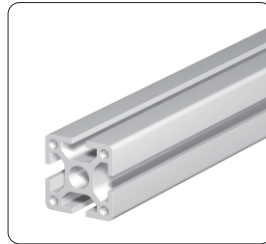

Manufacture the cross bushing bore with the aid of a drill jig

**3. Pre-assembly of the connector**

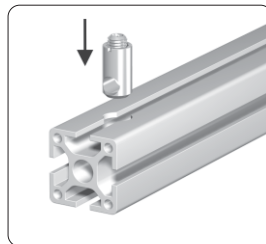

Insert the cross bushing

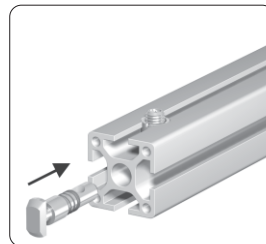

Push in the anchor

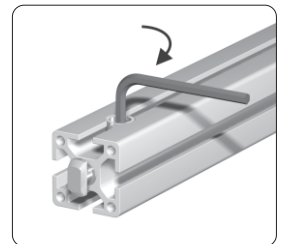

Pretension the anchor

**⚠ Mounting position**

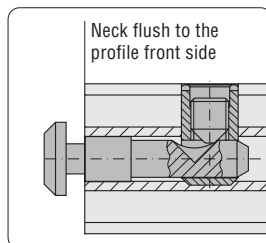

Neck flush to the profile front side

**Comments**

For the optimal assembly of the profiles the connector is to be installed in such a way that the neck is flush to the profile front side

**4. Final assembly**

➤ 1.2F, Torque tightening values for connector setscrew

①

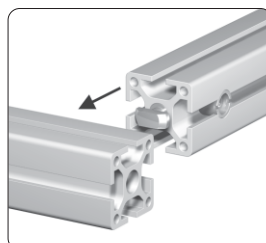

Push in sideways

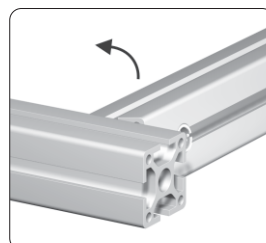

Turn the profile

or

②

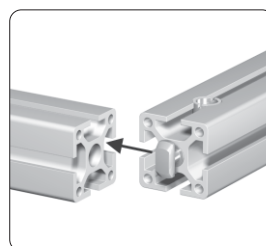

Push in front sided

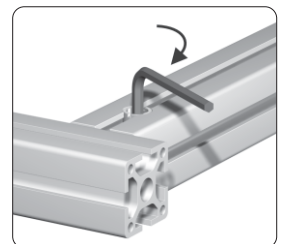

Tighten the setscrew

Connector selection		
Procedure		Example
① <b>Connection</b>	Selection of connector-variant	Standard
② <b>Profile 1</b>	Size of the profile in which the connector should be built into	30×30 mm
③ <b>Core hole</b>	Determination of the core hole $\varnothing$	$\varnothing 12$ mm
④ <b>Profile 2</b>	Determination of the connector-head according to slot-variant of the profile on which it will be joined	40×40 mm / E-slot
⑤ <b>Connector</b>	Determination of connector	<b>1.21.3E1</b>
⑥ <b>Number of degrees</b>	Bent anchor: determine the angle ( $0^\circ - 45^\circ$ )	

Connector types and materials		
Connector	Article-No.	Technical data
Standard	1.21.2E0	material: 9 S Mn Pb 28K strength: 460-710 N/mm <sup>2</sup> surface: galvanised
Standard, ground	1.21.2E0 E	
Standard VA	1.21.2E0 V	material: stainless steel 1.4305 strength: 490-685 N/mm <sup>2</sup> surface: pickled and passivated

Special cases				
Profile	Mounting position	PG for connector selection	Mounting position	PG for connector selection
20×30 30×50		20 30		30 50
30×100		30		50

MayTec		Connectors for profiles with core hole- $\varnothing 12$ mm			1.2A						
Connection / Connector	Finished dimension	PG	Article-No. for connector with								
			H-head		F-head		E-head				
			steel standard	E	VA	steel standard	E	VA	steel standard	E	VA
<b>Universal</b> 		20	1.21.2H0			1.21.2F0	E	V	1.21.2E0	E	V
		30	1.21.3H0			1.21.3F0	E	V	1.21.3E0	E	V
		40				1.21.4F0	E	V	1.21.4E0	E	V
		45				1.21.45F0	E	V	1.21.45E0	E	V
		50				1.21.5F0	E	V	1.21.5E0	E	V
		60				1.21.6F0	E	V	1.21.6E0	E	V
<b>Standard</b> 		20				1.21.2F1	E	V	1.21.2E1	E	V
		30				1.21.3F1	E	V	1.21.3E1	E	V
		40				1.21.4F1	E	V	1.21.4E1	E	V
		45				1.21.45F1	E	V	1.21.45E1	E	V
		50				1.21.5F1	E	V	1.21.5E1	E	V
		60				1.21.6F1	E	V	1.21.6E1	E	V
<b>90°</b> 		20				1.21.2F2	E	V	1.21.2E2	E	V
		30				1.21.3F2	E	V	1.21.3E2	E	V
		40				1.21.4F2	E	V	1.21.4E2	E	V
		45				1.21.45F2	E	V	1.21.45E2	E	V
		50				1.21.5F2	E	V	1.21.5E2	E	V
		60				1.21.6F2	E	V	1.21.6E2	E	V
<b>Oblique -hinge l + r</b> 		20				1.21.2FK1		V	1.21.2EK1		V
		30				1.21.3FK1		V	1.21.3EK1		V
		40				1.21.4FK1		V	1.21.4EK1		V
		45				1.21.45FK1		V	1.21.45EK1		V
		50				1.21.5FK1		V	1.21.5EK1		V
		60				1.21.6FK1		V	1.21.6EK1		V
<b>-bent anchor l</b> 		20				1.21.2FB1L/□□	E		1.21.2EB1L/□□	E	
		30				1.21.3FB1L/□□	E		1.21.3EB1L/□□	E	
		40				1.21.4FB1L/□□	E		1.21.4EB1L/□□	E	

Connection / Connector	Finished dimension	PG	Article-No. for connector with								
			H-head		F-head		E-head				
			steel standard	E	VA	steel standard	E	VA	steel standard	E	VA
Universal 		20	1.20.2H0		V	1.20.2F0			1.20.2E0		
Oblique -hinge l + r 		20	1.20.2HK1			1.20.2FK1					
Oblique 90° -hinge 		20	1.20.2HK2			1.20.2FK2					
Parallel -square 		20	1.20.2H0		V	1.20.2F0			1.20.2E0		
-cross 											
-high 											

Connection / Connector	Finished dimension	PG	Article-No. for connector	
			steel standard	VA
Miter -hinge l + r 		20	1.20.2G1	E
Miter 90° -hinge l + r 		20	1.20.2G2	
Extension 		20	1.20.2V0	V

**Machining of profiles with core hole-Ø 6 mm for miter**

In order not to reduce the strength of the miter joint one profile end must be counterbored

drill hole  $\varnothing 6.5$

The center portion of the anchor part is to be located in the counterbored profile section

anchor mounted

**Comments**  
Use drill for miter anchor Article-No.: 1.99.0310800 ↗ tools 1.99



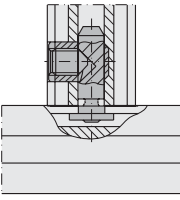
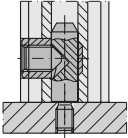
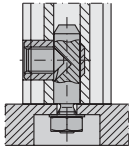



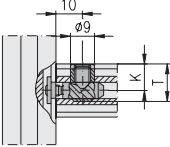
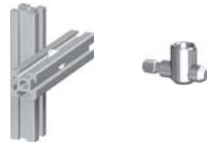
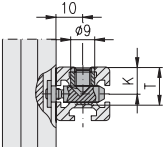
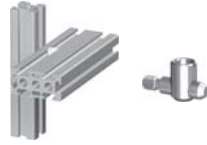
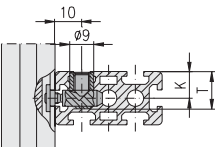
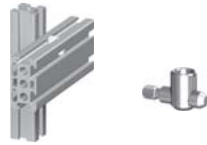
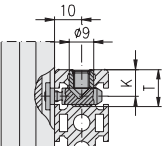

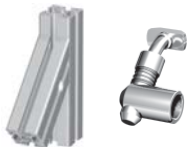
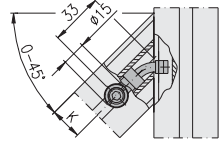

E = ground-connector, VA = stainless steel 1.4305

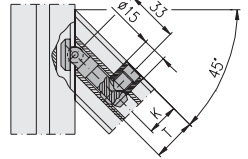
Connection variants with screw-type connectors		
		
Profile with profile	Profile to plate with thread	Profile to plate with through-hole

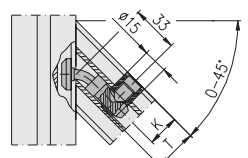
Mounting instruction for screw-type connectors
<ol style="list-style-type: none"> <li>1. Screw anchor in until it stops against the shoulder</li> <li>2. Unscrew anchor until it lines-up with the cross bushing position (max. one turn)</li> <li>3. Set up profile with cross bushing</li> </ol>

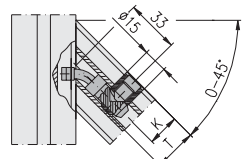
Connection / Connector	Finished dimension	PG	thread	Article-No. for connector	
				steel standard	VA E
Screw-type front sided 		20	M4×7	1.20.2S2M4/7	V
			M5×7	1.20.2S2M5/7	
			M6×7	1.20.2S2M6/7	
Screw-type parallel -square 					
-cross 					
-high 					

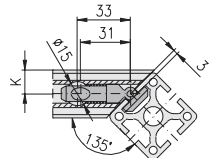
Connection / Connector	Finished dimension	PG	Article-No. for connector with								
			H-head		F-head		E-head				
			steel standard	E	VA	steel standard	E	VA	steel standard	E	VA
<b>Universal</b> 		20	1.21.2H0			1.21.2F0	E	V	1.21.2E0	E	V
		30	1.21.3H0			1.21.3F0	E	V	1.21.3E0	E	V
		40				1.21.4F0	E	V	1.21.4E0	E	V
		45				1.21.45F0	E	V	1.21.45E0	E	V
		50				1.21.5F0	E	V	1.21.5E0	E	V
		60				1.21.6F0	E	V	1.21.6E0	E	V
<b>Standard</b> 		20				1.21.2F1	E	V	1.21.2E1	E	V
		30				1.21.3F1	E	V	1.21.3E1	E	V
		40				1.21.4F1	E	V	1.21.4E1	E	V
		45				1.21.45F1	E	V	1.21.45E1	E	V
		50				1.21.5F1	E	V	1.21.5E1	E	V
		60				1.21.6F1	E	V	1.21.6E1	E	V
<b>90°</b> 		20				1.21.2F2	E	V	1.21.2E2	E	V
		30				1.21.3F2	E	V	1.21.3E2	E	V
		40				1.21.4F2	E	V	1.21.4E2	E	V
		45				1.21.45F2	E	V	1.21.45E2	E	V
		50				1.21.5F2	E	V	1.21.5E2	E	V
		60				1.21.6F2	E	V	1.21.6E2	E	V
<b>Square head</b> 		20							1.21.20E4		
		30							1.21.30E4		
		40							1.21.40E4		
		45							1.21.45E4		
		50							1.21.50E4		
		60							1.21.60E4		
<b>Oblique -hinge l + r</b> 		20				1.21.2FK1		V	1.21.2EK1		V
		30				1.21.3FK1		V	1.21.3EK1		V
		40				1.21.4FK1		V	1.21.4EK1		V
		45				1.21.45FK1		V	1.21.45EK1		V
		50				1.21.5FK1		V	1.21.5EK1		V
		60				1.21.6FK1		V	1.21.6EK1		V
<b>-bent anchor l</b> 		20				1.21.2FB1L/□□	E		1.21.2EB1L/□□	E	
		30				1.21.3FB1L/□□	E		1.21.3EB1L/□□	E	
		40				1.21.4FB1L/□□	E		1.21.4EB1L/□□	E	
		45				1.21.45FB1L/□□	E		1.21.45EB1L/□□	E	
		50				1.21.5FB1L/□□	E		1.21.5EB1L/□□	E	
		60				1.21.6FB1L/□□	E		1.21.6EB1L/□□	E	
<b>-bent anchor standard l</b> 		20				1.21.2F1B1L/□□			1.21.2E1B1L/□□		
		30				1.21.3F1B1L/□□			1.21.3E1B1L/□□		
		40				1.21.4F1B1L/□□			1.21.4E1B1L/□□		
		45				1.21.45F1B1L/□□			1.21.45E1B1L/□□		
		50				1.21.5F1B1L/□□			1.21.5E1B1L/□□		
		60				1.21.6F1B1L/□□			1.21.6E1B1L/□□		
<b>-bent anchor r</b> 		20				1.21.2FB1R/□□	E		1.21.2EB1R/□□	E	
		30				1.21.3FB1R/□□	E		1.21.3EB1R/□□	E	
		40				1.21.4FB1R/□□	E		1.21.4EB1R/□□	E	
		45				1.21.45FB1R/□□	E		1.21.45EB1R/□□	E	
		50				1.21.5FB1R/□□	E		1.21.5EB1R/□□	E	
		60				1.21.6FB1R/□□	E		1.21.6EB1R/□□	E	

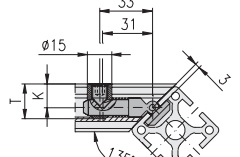





Connection / Connector	Finished dimension	PG	Article-No. for connector with									
			H-head		F-head		E-head					
			steel standard	E	VA	steel standard	E	VA	steel standard	E	VA	
Oblique -bent anchor standard r 		20				1.21.2F1B1R/□□				1.21.2E1B1R/□□		
		30				1.21.3F1B1R/□□				1.21.3E1B1R/□□		
		40				1.21.4F1B1R/□□				1.21.4E1B1R/□□		
		45				1.21.45F1B1R/□□				1.21.45E1B1R/□□		
		50				1.21.5F1B1R/□□				1.21.5E1B1R/□□		
		60				1.21.6F1B1R/□□				1.21.6E1B1R/□□		
Oblique 90° -hinge 		20				1.21.2FK2		V		1.21.2EK2		V
		30				1.21.3FK2		V		1.21.3EK2		V
		40				1.21.4FK2		V		1.21.4EK2		V
		45				1.21.45FK2		V		1.21.45EK2		V
		50				1.21.5FK2		V		1.21.5EK2		V
		60				1.21.6FK2		V		1.21.6EK2		V
-bent anchor 		20				1.21.2FB2/□□		E		1.21.2EB2/□□		E
		30				1.21.3FB2/□□		E		1.21.3EB2/□□		E
		40				1.21.4FB2/□□		E		1.21.4EB2/□□		E
		45				1.21.45FB2/□□		E		1.21.45EB2/□□		E
		50				1.21.5FB2/□□		E		1.21.5EB2/□□		E
		60				1.21.6FB2/□□		E		1.21.6EB2/□□		E
-bent anchor 90° 		20				1.21.2F2B2/□□				1.21.2E2B2/□□		
		30				1.21.3F2B2/□□				1.21.3E2B2/□□		
		40				1.21.4F2B2/□□				1.21.4E2B2/□□		
		45				1.21.45F2B2/□□				1.21.45E2B2/□□		
		50				1.21.5F2B2/□□				1.21.5E2B2/□□		
		60				1.21.6F2B2/□□				1.21.6E2B2/□□		
Oblique-cross-hinge 		20				1.21.2FK3				1.21.2EK3		V
		30				1.21.3FK3				1.21.3EK3		V
		40				1.21.4FK3				1.21.4EK3		V
		45				1.21.45FK3				1.21.45EK3		V
		50				1.21.5FK3				1.21.5EK3		V
		60				1.21.6FK3				1.21.6EK3		V
90° 		20				1.21.2FK4				1.21.2EK4		V
		30				1.21.3FK4				1.21.3EK4		V
		40				1.21.4FK4				1.21.4EK4		V
		45				1.21.45FK4				1.21.45EK4		V
		50				1.21.5FK4				1.21.5EK4		V
		60				1.21.6FK4				1.21.6EK4		V

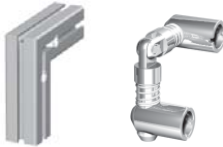
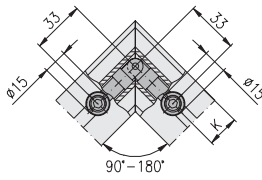
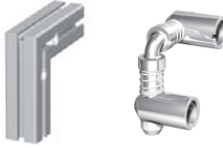
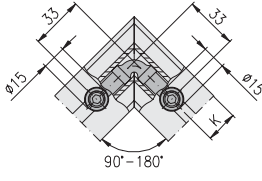

Connection / Connector	Finished dimension	PG	Article-No. for connector with								
			H-head		F-head		E-head				
			steel standard	E	VA	steel standard	E	VA	steel standard	E	VA
Parallel -square 		20									
		30									
		40				1.21.3F5			1.21.3E5		
		45				1.21.4F5			1.21.4E5		
		50				1.21.45F5			1.21.45E5		
		60				1.21.5F5			1.21.5E5		
-square 90° 		20									
		30									
		40							1.21.3E2-5		
		45									
		50									
		60									
-cross 		20									
		30				1.21.2/3F5			1.21.2/3E5		
		40				1.21.3/5F5			1.21.3/5E5		
		45									
		50									
		60									
-high 		20									
		30				1.21.3/2F5			1.21.3/2E5		
		40									
		45									
		50				1.21.5/3F5			1.21.5/3E5		
		60									
-high 90° 		20									
		30									
		40									
		45									
		50							1.21.5/3E2-5		
		60									

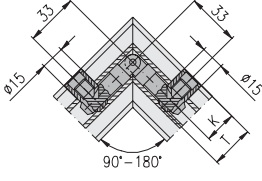
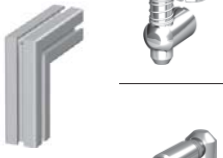
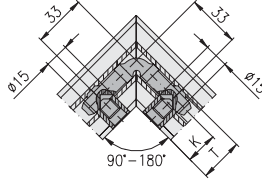
Connection / Connector	Finished dimension	PG, K×2	Article-No. for connector			PG, K×2	Article-No. for connector		
			steel standard	E	VA		steel standard	E	VA
Extension 		20	1.21.2V0		V				
		30	1.21.3V0		V				
		40	1.21.4V0		V				
		45	1.21.45V0		V				
		50	1.21.5V0		V				
		60	1.21.6V0		V				
		30/20	1.21.3/2V0		V	60/20	1.21.6/2V0	V	
		40/20	1.21.4/2V0		V	30	1.21.6/3V0	V	
		30	1.21.4/3V0		V	40	1.21.6/4V0	V	
		45/20	1.21.45/2V0		V	45	1.21.6/45V0	V	
		30	1.21.45/3V0		V	50	1.21.6/5V0	V	
		40	1.21.45/4V0		V				
		50/20	1.21.5/2V0		V				
		30	1.21.5/3V0		V				
		40	1.21.5/4V0		V				
		45	1.21.5/45V0		V				

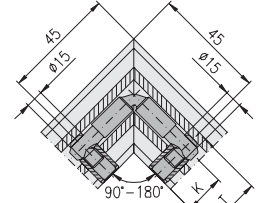
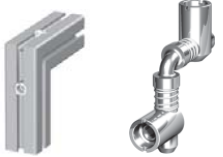
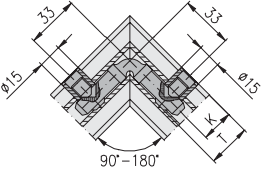
E = ground-connector, VA = stainless steel 1.4305

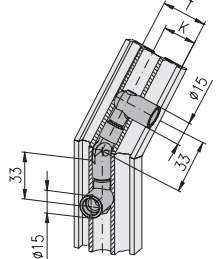
Connection / Connector	Finished dimension	PG	Article-No. for connector	
			steel standard	VA
<b>Miter</b> -hinge l + r  		20	1.21.2G1	V
		30	1.21.3G1	V
		40	1.21.4G1	V
		45	1.21.45G1	V
		50	1.21.5G1	V
		60	1.21.6G1	V
<b>-bent anchor l + r</b>  		20	1.21.2GB1/□□	
		30	1.21.3GB1/□□	
		40	1.21.4GB1/□□	
		45	1.21.45GB1/□□	
		50	1.21.5GB1/□□	
		60	1.21.6GB1/□□	
<b>Miter 90°</b> -hinge l + r  		20	1.21.2G2	V
		30	1.21.3G2	V
		40	1.21.4G2	V
		45	1.21.45G2	V
		50	1.21.5G2	V
		60	1.21.6G2	V
<b>-bent anchor l</b>  		20	1.21.2GB2L/□□	
		30	1.21.3GB2L/□□	
		40	1.21.4GB2L/□□	
		45	1.21.45GB2L/□□	
		50		
		60		
		20		
		30		
		40		
		45		
		50	1.21.5GB2L/□□	
		60	1.21.6GB2L/□□	
<b>-bent anchor r</b>  		20	1.21.2GB2R/□□	
		30	1.21.3GB2R/□□	
		40	1.21.4GB2R/□□	
		45	1.21.45GB2R/□□	
		50	1.21.5GB2R/□□	
		60	1.21.6GB2R/□□	
<b>Shifter</b>  		20	1.21.2GS	
		30	1.21.3GS	
		40	1.21.4GS	
		45	1.21.45GS	
		50	1.21.5GS	
		60	1.21.6GS	

Connection variants with screw-type connectors		
Profile with profile	Profile to plate with thread	Profile to plate with through-hole

Mounting instruction for screw-type connectors
1. Screw anchor in until it stops against the shoulder
2. Unscrew anchor until it lines-up with the cross bushing position (max. one turn)
3. Set up profile with cross bushing

Connection / Connector	Finished dimension	PG	thread	Article-No. for connectors for mounting on profiles with						
				F-slot		E-slot		other		
				Length of thread						
7 mm		11 mm		40 mm						
steel standard	E	VA	steel standard	E	VA	steel standard	E	VA		
<b>Screw-type - front sided</b> 	20 30 40 45 50 60	M6				1.21.2S1M6/11				
						1.21.3S1M6/11				
						1.21.4S1M6/11				
						1.21.45S1M6/11				
						1.21.5S1M6/11				
						1.21.6S1M6/11				
	20 30 40 45 50 60	M8	1.21.20S1M8/7			1.21.2S1M8/11		V		
			1.21.30S1M8/7			1.21.3S1M8/11		V		
			1.21.40S1M8/7			1.21.4S1M8/11		V		
			1.21.45S1M8/7			1.21.45S1M8/11		V		
			1.21.50S1M8/7			1.21.5S1M8/11		V		
			1.21.60S1M8/7			1.21.6S1M8/11		V		
	20 30 40 45 50 60	M8						1.21.2S1M8/40		
								1.21.3S1M8/40		
							1.21.4S1M8/40			
							1.21.45S1M8/40			
							1.21.5S1M8/40			
							1.21.6S1M8/40			
<b>Screw-type - parallel-square</b> 	20 30 40 45 50 60	M8				1.21.2S5M8/11				
			1.21.3S5M8/7			1.21.3S5M8/11				
			1.21.4S5M8/7			1.21.4S5M8/11				
						1.21.45S5M8/11				
						1.21.5S5M8/11				
						1.21.6S5M8/11				
<b>-cross</b> 	20 30 40 45 50 60	M8				1.21.2/3S5M8/11				
						1.21.3/5S5M8/11				
<b>-high</b> 	20 30 40 45 50 60	M8				1.21.3/2S5M8/11				
								1.21.5/3S5M8/11		

E = ground-connector, VA = stainless steel 1.4305

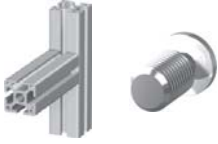
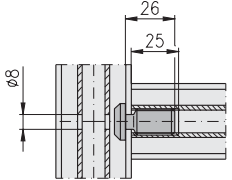
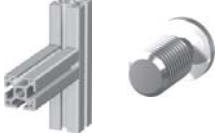
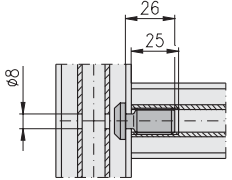
Connection/ Connector	Finished dimension	Article-No. for connector with						
		H-head		F-head		E-head		
		steel standard	E	VA	steel standard	E	VA	
Connector screw 					1.21.VSFM14		1.21.VSEM14	
-self-cutting 					1.21.VSFS13		1.21.VSES13	

## Drill dimensions for connector cross bushings

Slot type	Cross bushing	PG/ Profile/ Slot	Core hole distance <b>K</b>	Boring depth, Cross bushing length <b>T</b>	Article-No.		
					steel	VA	
H-slots		20	10	14	1.20.B21	V	
F + E-slots		20	10	17	1.21.B20	V	
		30	15	22	1.21.B30	V	
		40	20	27	1.21.B40	V	
		40	20	27	1.21.B40R		
		45	22,5	29,5	1.21.B45	V	
		50	25	32	1.21.B50	V	
		60	30	37	1.21.B60	V	
E-slots	Special- universal- connector for profile 30x150	30x150	15	30	1.21.B31		
	Special- SE-Connector		16, E3	-	15	1.21.BE3	
			E4	-	16	1.21.BE4	
	Special- ST-Connector	E	-	19	1.21.STBM6		
	Special- ST-Connector with screw-type anchor		16, E3	-	40	1.21.ST4B40	

tools 1.99



## Drill dimensions for connector cross bushings - Special cases

Profile	Cross bushing		PG/ Profile/ Slot	Core hole distance <b>K</b>	Boring depth, Cross bushing length <b>T</b>	Article-No.	
						steel	VA
1.10.020020.21P			20	10	14	1.20.B22	
1.11.030030.21(P)			30	15	22	1.21.B34	
1.11.030150.84P			40	20	27	1.21.B44	
1.11.040040.28LP							

tools 1.99

## Mounting variants

Standard application: Cross bushing, flush	Special application: Cross bushing for the next smaller profile	
	for the application of panels	for the application of cover profiles

Connector components

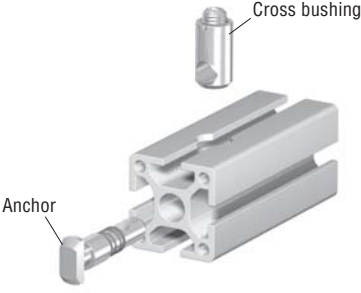

As an alternative to the complete connector it is also possible to order the component parts.  
Because of the extensive combination possibilities, storage of the complete connectors will be reduced by over 80%.

Connector components for profiles with  
core hole-Ø 6 mm → 101  
core hole-Ø 12 mm → 102-105

Connector for core hole-Ø 6 mm			Connector complete			Single parts					
			PG 20			Anchor		Piece			
			steel standard	E	VA	steel standard	E	VA			
		Universal	1.20.2H0		V	1.20.A2H0		V	1	1	
			1.20.2F0			1.20.A2F0			1	1	
			1.20.2E0			1.20.A2E0			1	1	
		Oblique -hinge l + r	1.20.2HK1			1.20.A2HK1			1	1	
			1.20.2FK1			1.20.A2FK1			1	1	
		90° -hinge	1.20.2HK2			1.20.A2HK2			1	1	
			1.20.2FK2			1.20.A2FK2			1	1	
		Parallel -square <sup>1)</sup>	1.20.2H0		V						
			1.20.2F0								
			1.20.2E0								
		-cross <sup>1)</sup>	1.20.2H0		V						
			1.20.2F0								
			1.20.2E0								
		-high <sup>1)</sup>	1.20.2H0		V						
			1.20.2F0								
			1.20.2E0								
		Miter -hinge l + r	1.20.2G1			1.20.A2G1			1	2	
		90° -hinge l + r	1.20.2G2			1.20.A2G2			1	2	
		Extension	1.20.2V0		V	1.20.A2V0		V	1	2	
		Screw-type	1.20.2S2M4/7		V	1.20.A2S2M4/7		V	1	1	
			1.20.2S2M5/7			1.20.A2S2M5/7			1	1	
			1.20.2S2M6/7			1.20.A2S2M6/7			1	1	
		-Parallel-square <sup>2)</sup>	1.20.2S2M4/7		V						
			1.20.2S2M5/7								
			1.20.2S2M6/7								
		-Parallel-cross <sup>2)</sup>	1.20.2S2M4/7		V						
			1.20.2S2M5/7								
			1.20.2S2M6/7								
		-Parallel-high <sup>2)</sup>	1.20.2S2M4/7		V						
			1.20.2S2M5/7								
			1.20.2S2M6/7								













	Cross bushing, steel	1.20.B21		Cross bushing, steel
	Cross bushing, VA	1.20.B21	V	Cross bushing, VA



E = ground-connector, VA = stainless steel 1.4305

<sup>1)</sup> = Connector, universal

<sup>2)</sup> = Connector, screw-type

2

Connector for core hole Ø12 mm			Connectors, complete								
			PG 20		PG 30		PG 40				
			steel standard	E VA	steel standard	E VA	steel standard	E VA			
		Universal	1.21.2H0		1.21.3H0		1.21.4F0				
			1.21.2F0	E V	1.21.3F0	E V	1.21.4E0	E V			
			1.21.2E0	E V	1.21.3E0	E V	1.21.4E0	E V			
		Standard	1.21.2F1	E V	1.21.3F1	E V	1.21.4F1	E V			
			1.21.2E1	E V	1.21.3E1	E V	1.21.4E1	E V			
		90°	1.21.2F2	E V	1.21.3F2	E V	1.21.4F2	E V			
			1.21.2E2	E V	1.21.3E2	E V	1.21.4E2	E V			
			Square head	1.21.20F4		1.21.30F4		1.21.40F4			
				1.21.20E4		1.21.30E4		1.21.40E4			
		Oblique	-hinge l + r	1.21.2FK1	V	1.21.3FK1	V	1.21.4FK1	V		
				1.21.2EK1	V	1.21.3EK1	V	1.21.4EK1	V		
		-bent anchor l	1.21.2FB1L/□□	E	1.21.3FB1L/□□	E	1.21.4FB1L/□□	E			
			1.21.2EB1L/□□	E	1.21.3EB1L/□□	E	1.21.4EB1L/□□	E			
		-bent a. standard l	1.21.2F1B1L/□□		1.21.3F1B1L/□□		1.21.4F1B1L/□□				
			1.21.2E1B1L/□□		1.21.3E1B1L/□□		1.21.4E1B1L/□□				
		-bent anchor r	1.21.2FB1R/□□	E	1.21.3FB1R/□□	E	1.21.4FB1R/□□	E			
			1.21.2EB1R/□□	E	1.21.3EB1R/□□	E	1.21.4EB1R/□□	E			
		-bent a. standard r	1.21.2F1B1R/□□		1.21.3F1B1R/□□		1.21.4F1B1R/□□				
			1.21.2E1B1R/□□		1.21.3E1B1R/□□		1.21.4E1B1R/□□				
		90°	-hinge	1.21.2FK2	V	1.21.3FK2	V	1.21.4FK2	V		
				1.21.2EK2	V	1.21.3EK2	V	1.21.4EK2	V		
			-bent anchor	1.21.2FB2/□□	E	1.21.3FB2/□□	E	1.21.4FB2/□□	E		
				1.21.2EB2/□□	E	1.21.3EB2/□□	E	1.21.4EB2/□□	E		
			-bent anchor 90°	1.21.2F2B2/□□		1.21.3F2B2/□□		1.21.4F2B2/□□			
				1.21.2E2B2/□□		1.21.3E2B2/□□		1.21.4E2B2/□□			
				Oblique-cross	-hinge	1.21.2FK3		1.21.3FK3		1.21.4FK3	
						1.21.2EK3	V	1.21.3EK3	V	1.21.4EK3	V
-hinge 90°	1.21.2FK4				1.21.3FK4		1.21.4FK4				
	1.21.2EK4			V	1.21.3EK4	V	1.21.4EK4	V			
		Parallel	-square			1.21.3/2F5 <sup>2)</sup>					
						1.21.3/2E5 <sup>2)</sup>					
				1.21.2/3F5 <sup>1)</sup>		1.21.3F5					
				1.21.2/3E5 <sup>1)</sup>		1.21.3E5					
						1.21.3E2-5					
							1.21.4F5				
							1.21.4E5				
						1.21.3/5F5 <sup>1)</sup>					
						1.21.3/5E5 <sup>1)</sup>					
		Miter	-hinge l + r	1.21.2G1	V	1.21.3G1	V	1.21.4G1	V		
				1.21.2GB1/□□		1.21.3GB1/□□		1.21.4GB1/□□			
		90°	-hinge l + r	1.21.2G2	V	1.21.3G2	V	1.21.4G2	V		
			-bent anchor l	1.21.2GB2L/□□		1.21.3GB2L/□□		1.21.4GB2L/□□			
			-bent anchor r	1.21.2GB2R/□□		1.21.3GB2R/□□		1.21.4GB2R/□□			

	Cross bushing, steel	1.21.B20		1.21.B30		1.21.B40	
	Cross bushing, VA		1.21.B20 V		1.21.B30 V		1.21.B40 V

E = ground-connector, VA = stainless steel 1.4305



PG 45							PG 50							PG 60							Single parts		
steel standard		VA	steel standard		VA	steel standard		VA	steel standard		VA	steel standard		VA	Anchor		Piece						
E	V	E	V	E	V	E	V	E	V	E	V	E	V	E	VA								
1.21.45F0	E	V	1.21.5F0	E	V	1.21.6F0	E	V	1.21.A1H0			1	1										
1.21.45E0	E	V	1.21.5E0	E	V	1.21.6E0	E	V	1.21.A1F0	E	V	1	1										
1.21.45F1	E	V	1.21.5F1	E	V	1.21.6F1	E	V	1.21.A1E0	E	V	1	1										
1.21.45E1	E	V	1.21.5E1	E	V	1.21.6E1	E	V	1.21.A1F1	E	V	1	1										
1.21.45F2	E	V	1.21.5F2	E	V	1.21.6F2	E	V	1.21.A1E1	E	V	1	1										
1.21.45E2	E	V	1.21.5E2	E	V	1.21.6E2	E	V	1.21.A1F2	E	V	1	1										
1.21.45F4			1.21.50F4			1.21.60F4			1.21.A1E2	E	V	1	1										
1.21.45E4			1.21.50E4			1.21.60E4			1.21.A1F4			1	1										
1.21.45FK1		V	1.21.5FK1		V	1.21.6FK1		V	1.21.A1E4			1	1										
1.21.45EK1		V	1.21.5EK1		V	1.21.6EK1		V	1.21.A1FK1	V		1	1										
1.21.45FB1L/□□	E		1.21.5FB1L/□□	E		1.21.6FB1L/□□	E		1.21.A1EK1	V		1	1										
1.21.45EB1L/□□	E		1.21.5EB1L/□□	E		1.21.6EB1L/□□	E		1.21.A1FB1L/□□	E		1	1										
1.21.45F1B1L/□□			1.21.5F1B1L/□□			1.21.6F1B1L/□□			1.21.A1EB1L/□□	E		1	1										
1.21.45E1B1L/□□			1.21.5E1B1L/□□			1.21.6E1B1L/□□			1.21.A1F1B1L/□□			1	1										
1.21.45FB1R/□□	E		1.21.5FB1R/□□	E		1.21.6FB1R/□□	E		1.21.A1E1B1L/□□			1	1										
1.21.45EB1R/□□	E		1.21.5EB1R/□□	E		1.21.6EB1R/□□	E		1.21.A1FB1R/□□	E		1	1										
1.21.45F1B1R/□□			1.21.5F1B1R/□□			1.21.6F1B1R/□□			1.21.A1EB1R/□□	E		1	1										
1.21.45E1B1R/□□			1.21.5E1B1R/□□			1.21.6E1B1R/□□			1.21.A1F1B1R/□□			1	1										
1.21.45FK2		V	1.21.5FK2		V	1.21.6FK2		V	1.21.A1E1B1R/□□			1	1										
1.21.45EK2		V	1.21.5EK2		V	1.21.6EK2		V	1.21.A1FK2	V		1	1										
1.21.45FB2/□□	E		1.21.5FB2/□□	E		1.21.6FB2/□□	E		1.21.A1EK2	V		1	1										
1.21.45EB2/□□	E		1.21.5EB2/□□	E		1.21.6EB2/□□	E		1.21.A1FB2/□□	E		1	1										
1.21.45F2B2/□□			1.21.5F2B2/□□			1.21.6F2B2/□□			1.21.A1EB2/□□	E		1	1										
1.21.45E2B2/□□			1.21.5E2B2/□□			1.21.6E2B2/□□			1.21.A1F2B2/□□			1	1										
1.21.45FK3			1.21.5FK3			1.21.6FK3			1.21.A1E2B2/□□			1	1										
1.21.45EK3		V	1.21.5EK3		V	1.21.6EK3		V	1.21.A1FK3			1	1										
1.21.45FK4			1.21.5FK4			1.21.6FK4			1.21.A1EK3	V		1	1										
1.21.45EK4		V	1.21.5EK4		V	1.21.6EK4		V	1.21.A1FK4			1	1										
									1.21.A1EK4	V		1	1										
									1.21.A2F5			1	1										
									1.21.A2E5			1	1										
			1.21.5/3F5 <sup>2)</sup>						1.21.A3F5			1	1										
			1.21.5/3E5 <sup>2)</sup>						1.21.A3E5			1	1										
									1.21.A3E2-5			1	1										
									1.21.A4F5			1	1										
									1.21.A4E5			1	1										
1.21.45F5									1.21.A45F5			1	1										
1.21.45E5									1.21.A45E5			1	1										
			1.21.5F5						1.21.A5F5			1	1										
			1.21.5E5						1.21.A5E5			1	1										
						1.21.6F5			1.21.A6F5			1	1										
						1.21.6E5			1.21.A6E5			1	1										
			1.21.5/3E2-5						1.21.A3E2-5			1	1										
1.21.45G1		V	1.21.5G1		V	1.21.6G1		V	1.21.A1G1	V		1	2										
1.21.45GB1/□□			1.21.5GB1/□□			1.21.6GB1/□□			1.21.A1GB1/□□			1	2										
1.21.45G2		V	1.21.5G2		V	1.21.6G2		V	1.21.A1G2	V		1	2										
1.21.45GB2L/□□			1.21.5GB2L/□□			1.21.6GB2L/□□			1.21.A1GB2L/□□			1	2										
			1.21.5GB2R/□□			1.21.6GB2R/□□			1.21.A1GB245L/□□			1	2										
1.21.45GB2R/□□			1.21.5GB2R/□□			1.21.6GB2R/□□			1.21.A1GB2R/□□			1	2										
1.21.B45			1.21.B50			1.21.B60			<i>Cross bushing, steel</i>														
1.21.B45	V		1.21.B50	V		1.21.B60	V		<i>Cross bushing, VA</i>														

**Single parts**

Anchor















Base with spring

Cross bushing



Base with setscrew

Connector for core hole Ø12 mm			Connectors, complete								
			PG 20		PG 30		PG 40				
			steel standard	E	VA	steel standard	E	VA	steel standard	E	VA
		Shifter	1.21.2GS			1.21.3GS			1.21.4GS		
		Extension	1.21.2V0		V	1.21.3V0		V	1.21.4V0		V
						1.21.3/2V0		V	1.21.4/2V0 1.21.4/3V0		V V
		Screw-type -front sided	1.21.2S1M6/11			1.21.3S1M6/11			1.21.4S1M6/11		
			1.21.20S1M8/7			1.21.30S1M8/7			1.21.40S1M8/7		
			1.21.2S1M8/11		V	1.21.3S1M8/11		V	1.21.4S1M8/11		V
			1.21.2S1M8/40			1.21.3S1M8/40			1.21.4S1M8/40		
		-Parallel-square	1.21.2S5M8/11			1.21.3S5M8/7 1.21.3S5M8/11					
								1.21.4S5M8/7 1.21.4S5M8/11			
	-Parallel-cross	1.21.2/3S5M8/11			1.21.3/5S5M8/11						
		-Parallel-high			1.21.3/2S5M8/11						
	Cross bushing, steel	1.21.B20			1.21.B30			1.21.B40			
	Cross bushing, VA	1.21.B20		V	1.21.B30		V	1.21.B40		V	

E = ground-connector, VA = stainless steel 1.4305

						<b>Single parts</b>		1.21.B20	1.21.B30	1.21.B40	1.21.B45	1.21.B50	
PG 45		PG 50		PG 60		Anchor		Piece					
steel standard	E	VA steel standard	E	VA steel standard	E	VA steel standard	E	VA					
1.21.45GS		1.21.5GS		1.21.6GS		1.21.A1GS			1	2			
1.21.45V0	V	1.21.5V0	V	1.21.6V0	V	1.21.A1V0	V		1	2	-	-	-
1.21.45/2V0	V	1.21.5/2V0	V	1.21.6/2V0	V	1.21.A1V0	V		1	1	1	-	-
1.21.45/3V0	V	1.21.5/3V0	V	1.21.6/3V0	V	1.21.A1V0	V		1	1	-	1	-
1.21.45/4V0	V	1.21.5/4V0	V	1.21.6/4V0	V	1.21.A1V0	V		1	1	-	-	1
		1.21.5/45V0	V	1.21.6/45V0	V	1.21.A1V0	V		1	1	-	-	1
		1.21.6/5V0	V	1.21.A1V0	V	1.21.A1V0	V		1	1	-	-	1
1.21.45S1M6/11		1.21.5S1M6/11		1.21.6S1M6/11		1.21.A1SM6/11			1	1			
1.21.45S1M8/7		1.21.5S1M8/7		1.21.6S1M8/7		1.21.A1SM8/7			1	1			
1.21.45S1M8/11	V	1.21.5S1M8/11	V	1.21.6S1M8/11	V	1.21.A1SM8/11	V		1	1			
1.21.45S1M8/40		1.21.5S1M8/40		1.21.6S1M8/40		1.21.A1SM8/40			1	1			
						1.21.A2SM8/11			1	1			
						1.21.A3SM8/7			1	1			
						1.21.A3SM8/11			1	1			
						1.21.A4SM8/7			1	1			
1.21.45S5M8/11						1.21.A4SM8/11			1	1			
						1.21.A45SM8/11			1	1			
		1.21.5S5M8/11		1.21.6S5M8/11		1.21.A5SM8/11			1	1			
						1.21.A6SM8/11			1	1			
						1.21.A3SM8/11			1	1			
						1.21.A5SM8/11			1	1			
						1.21.A2SM8/11			1	1			
		1.21.5/3S5M8/11				1.21.A3SM8/11			1	1			
1.21.B45		1.21.B50		1.21.B60		<i>Cross bushing, steel</i>							
1.21.B45	V	1.21.B50	V	1.21.B60	V	<i>Cross bushing, VA</i>							

## Parallel connector for profile 30x30, soft

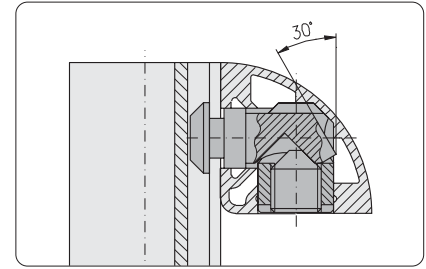
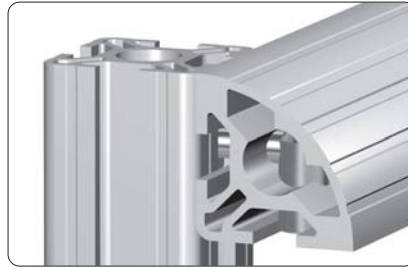

### Application

Special anchor for parallel connector for profile 30x30, 2 F-slots, soft

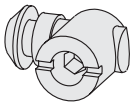

Description	Weight	Article-No.
Connector, parallel	40 g	1.21.31E5
Connector, parallel	33 g	1.21.31F5

### Single parts

Description	Weight	Article-No.
Anchor, incl. spring	23 g	1.21.A31E5
Anchor, incl. spring	16 g	1.21.A31F5
Cross bushing, incl. setscrew	17 g	1.21.B34

## Universal connector for profile 30x150

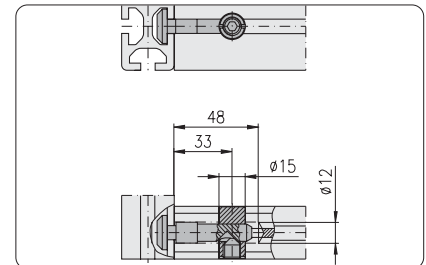

Drill dimensions

### Application

Universal connector for connection of two profiles 30x150  
Alternative connection possibility  
➔ *ST-Connector, 110*

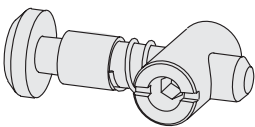

Description	Weight	Article-No.
Connector, universal	68 g	1.21.31E0

### Single parts

Description	Weight	Article-No.
Anchor, incl. spring	41 g	1.21.A1E0
Cross bushing, incl. setscrew	27 g	1.21.B31

## Extension / parallel connector

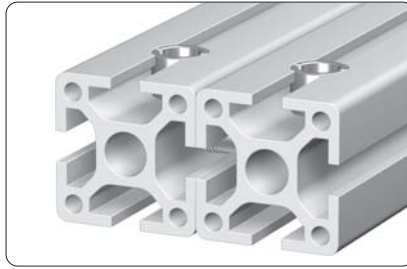

### Application

- Parallel connections with core hole distance of 40 mm
- Profile extensions

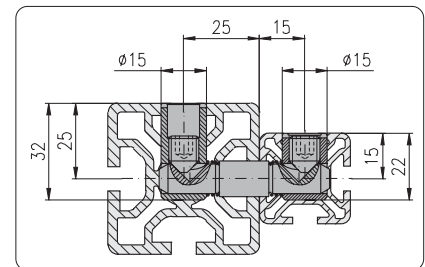
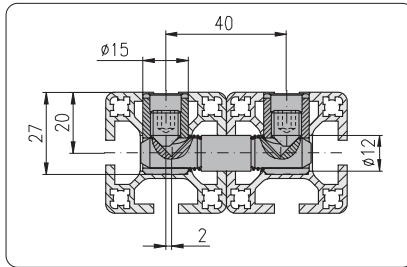

Insert front-sided

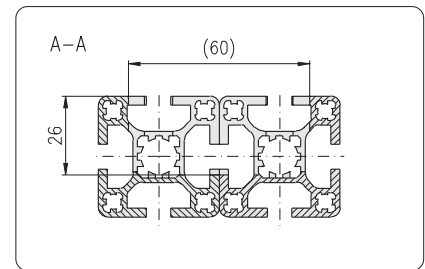

Profile machining

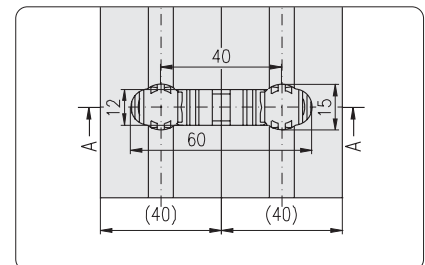

Profile machining

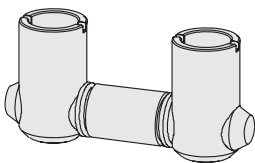

Description	Weight	Article-No.
Connector extension / parallel	76 g	1.21.40V040

### Single parts

Description	Pcs	Weight	Article-No.
Anchor for connector extension / parallel, incl. springs	1	36 g	1.21.A1V040
Cross bushing B40, incl. setscrew	2	20 g	1.21.B40

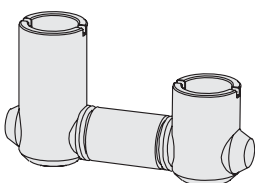

Description	Weight	Article-No.
Connector extension / parallel	76 g	1.21.50/30V040

### Single parts

Description	Pcs	Weight	Article-No.
Anchor for connector extension / parallel, incl. springs	1	36 g	1.21.A1V040
Cross bushing B50, incl. setscrew	1	25 g	1.21.B50
Cross bushing B30, incl. setscrew	1	15 g	1.21.B30

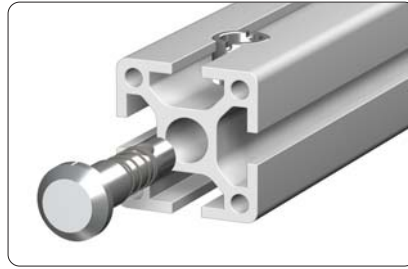
**Universal connector  
with knurled cross bushing**

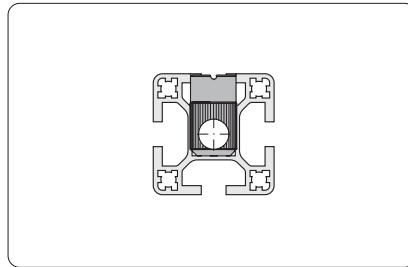
**Application**

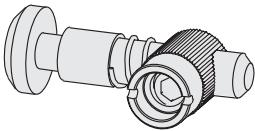
 Fixable cross bushing  
 Press in device ↗ 1.98

**Comments**

 The knurled cross bushing is suitable for all connectors with the cross bushing 1.21.B40  
 ↗ Connector components, 1.2C

Description	Weight	Article-No.
Connector, universal with knurled cross bushing	60 g	1.21.40RE0

**Single parts**

Description	Pcs	Weight	Article-No.
Anchor, incl. spring	1	40 g	1.21.A1E0
Cross bushing B40, knurled, incl. setscrew	1	20 g	1.21.B40R

SE-Connector

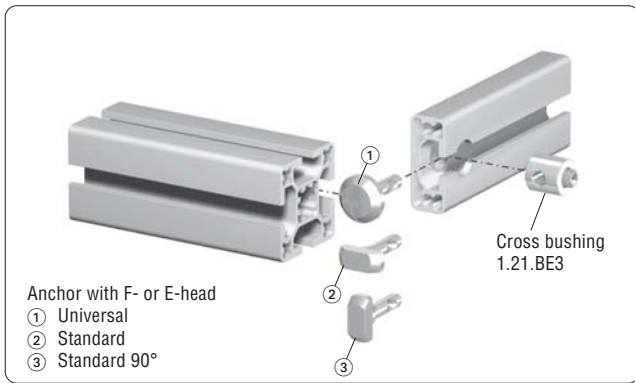

for profiles with E3-slot, PG16, E

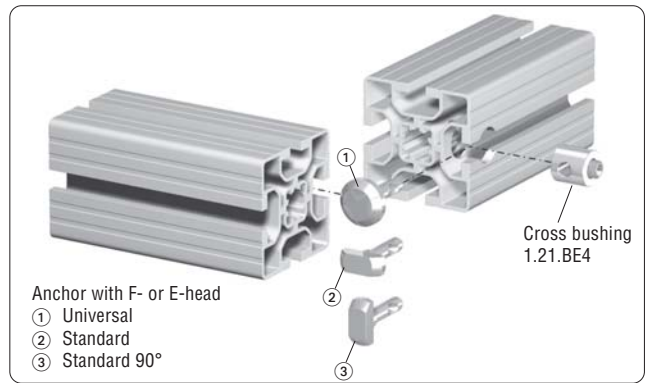

for profiles with E4-slot

Application

- for PG 16 E
- allows mounting of additional profiles into existing frames

Boring depth T	
mounting in	T
E3-slot	15 mm
E4-slot	16 mm

Drill distance L	
mounting on	L
F-slot	16 mm
E3-slot	15 mm
E4-slot	14 mm

Connection		Connection		Connector	Article-No. for SE-connector			
					mounting in E3-slot		mounting in E4-slot	
Profile PG16, E3-slot to F/E-slot		Profile with E4-slot to F/E-slot			steel standard	VA E	steel standard	VA E
Universal					1.21.SE3F0		1.21.SE4F0	
					1.21.SE3E0		1.21.SE4E0	
Standard					1.21.SE3F1		1.21.SE4F1	
					1.21.SE3E1		1.21.SE4E1	
90°					1.21.SE3F2		1.21.SE4F2	
					1.21.SE3E2		1.21.SE4E2	

Connectors for E3/E4-slot			Connectors, complete				Single parts		
			mounting in E3-slot		mounting in E4-slot		Anchor		Piece
			steel standard	VA E	steel standard	VA E	steel standard	E VA	
	Universal		1.21.SE3F0		1.21.SE4F0		1.21.ASEF0		1 1
			1.21.SE3E0		1.21.SE4E0		1.21.ASEE0		1 1
	Standard		1.21.SE3F1		1.21.SE4F1		1.21.ASEF1		1 1
			1.21.SE3E1		1.21.SE4E1		1.21.ASEE1		1 1
	90°		1.21.SE3F2		1.21.SE4F2		1.21.ASEF2		1 1
			1.21.SE3E2		1.21.SE4E2		1.21.ASEE2		1 1
		Cross bushing	1.21.BE3		1.21.BE4				

E = ground-connector, VA = stainless steel 1.4305

## ST-Connector



### Application

Connector for mounting into E-slot and for connection of profiles 30x150  
 Alternative connection possibility  
 ⇨ *Universal connector, 106*

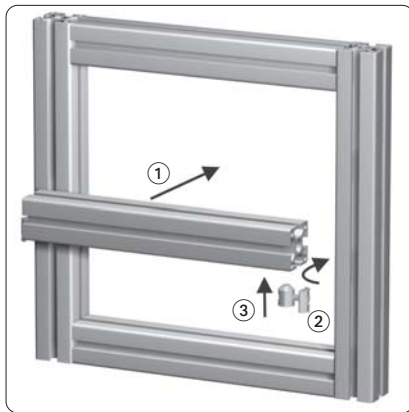

### Application

ST-Connector for later insertion of profiles into closed frames

### Assembly

- ① push the profile into the frame
- ② insert and rotate the T-Nut, pretension the screw (and cross bushing)
- ③ push the connector into the cross bushing bore, tighten the screw

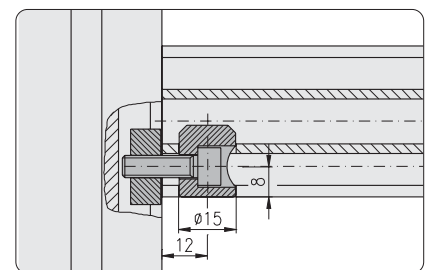
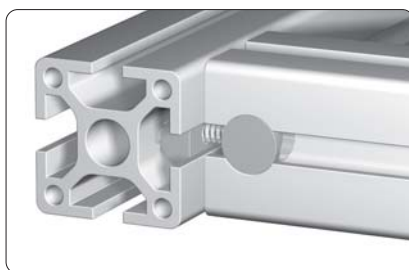
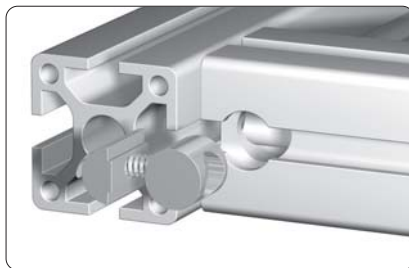

### Technical data

material: steel  
 surface: galvanised  
 torque: max. 14 Nm  
 tensile load: max. 5,000 N

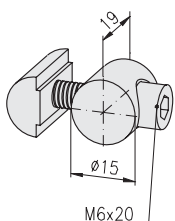

### Connector complete

Description	G	Weight	Article-No.
ST-Connector	M6	32.0 g	1.21.STEM620

### Single parts

ST-Cross bushing	M6	16.7 g	1.21.STBM6
T-Nut for subsequent insertion into E-slots	M6	10.0 g	1.324.EM6
Cap head screw DIN 912	M6x20	5.3 g	1.21.S0620





**ST-Connector  
with anchor, screw-type**



**Application**

ST-Connection for PG 16, E3-slot  
Eco-Slide ↗ 1.67

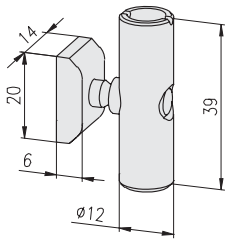
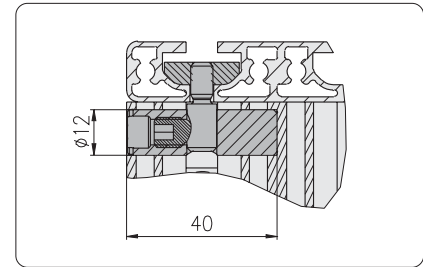
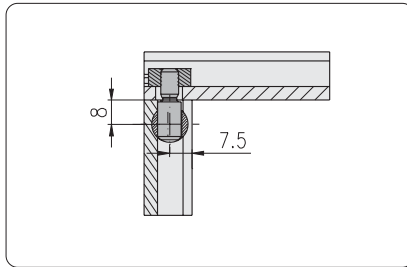

**Connector complete**

Description	G	Weight	Article-No.
ST-Connector with anchor, screw-type	M6	43.8 g	1.21.STESM6/11

**Single parts**

ST-Cross bushing		25.4 g	1.21.STSB40
Threaded plate, heavy, E	M6	12.4 g	1.317.EM6
Anchor, screw-type, for ST-Connector	M6×11	6.0 g	1.21.ASTM6/11

**Connector screw self-cutting**

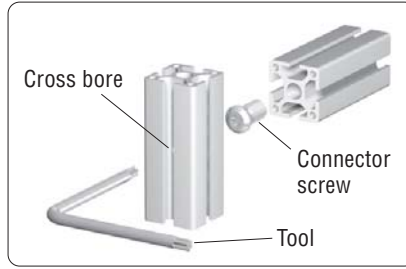

**Application**

Simple connections with profiles using a 12 mm core hole

**Technical data**

material: steel  
surface: galvanised

**Tool**

Tx screw driver for Torx 40 screws  
1.98.T40.090090

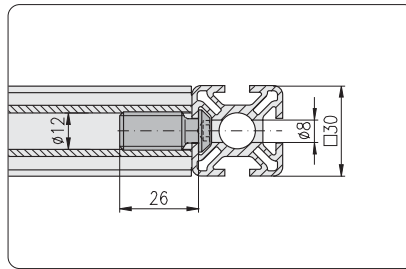
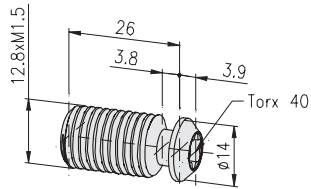

**Description**

Connector screw, self-cutting, F, S13

**Weight**

25.0 g

**Article-No.**

1.21.VSFS13

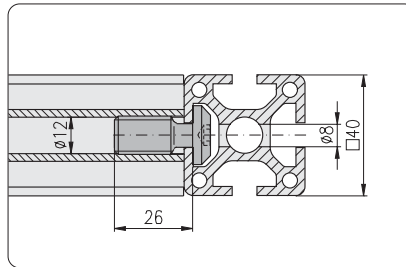
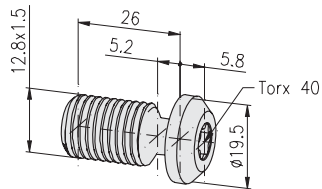

**Description**

Connector screw, self-cutting, E, S13

**Weight**

31.5 g

**Article-No.**

1.21.VSES13

**Bayonet type connector**

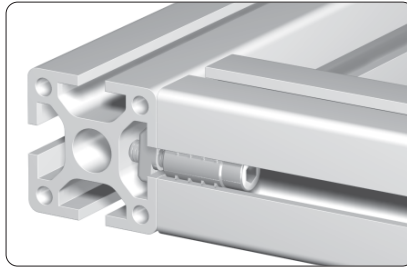

**Application**

Connection without profile machining.  
Suitable for the connection of profiles with E-slots to profiles with E- or F-slots.



**Application**

Suitable for the subsequent mounting of profiles

**Mounting example**

for bayonet type connector with T-slot nut

**Pre-assembly of the notching case**



insert the cap head screw and the notching case into the slot

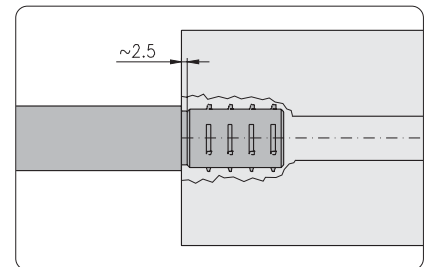

positioning with socket pin

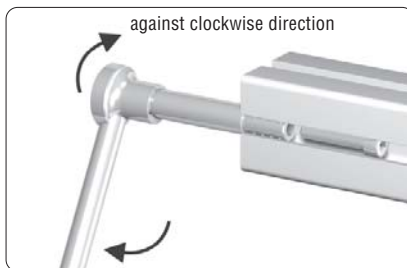

tighten the notching case (approx. 45° anti-clockwise turn)

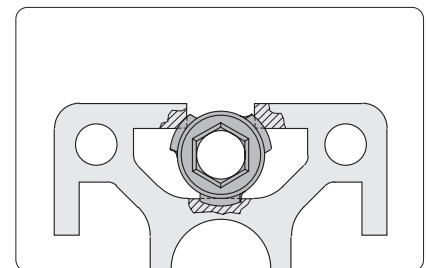

end position of the notching case

**Final assembly**



pre-mounting of the T-slot nut



pre-mounting of the T-slot nut



join the profiles and tighten the T-slot nut

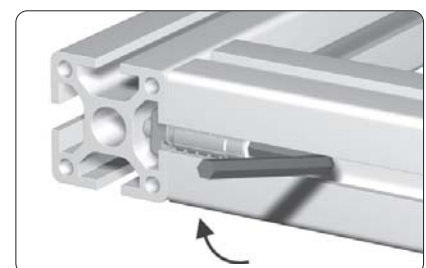

final tightening with socket spanner



## Bayonet type connector

### Technical data

- Notching case, cap head screw,  
T-Nut, socket pin:  
material: steel  
surface: galvanised
- T-slot nut:  
material: GD-Zn

### with T-Nut (spring ball)

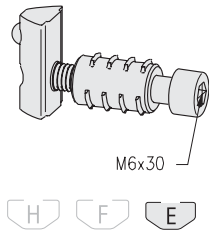

Description	Pcs.	Weight	Article-No.
Bayonet type connector E, with T-Nut (spring ball) E		24.4 g	1.25.E323E

### Single parts

Notching case E for bayonet type connector	1	7.5 g	1.25.BE
Cap head screw DIN 912, M6×30	1	8.0 g	0.63.D00912.06030
T-Nut for subs. insertion, with spring ball E, M6	1	9.9 g	1.323.EM6

### with T-Nut (spring)

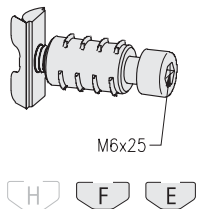

Description	Pcs.	Weight	Article-No.
Bayonet type connector E, with T-Nut (spring) F		18.8 g	1.25.E324F

### Single parts

Notching case E for bayonet type connector	1	7.5 g	1.25.BE
Cap head screw DIN 912, M6×25	1	7.0 g	0.63.D00912.06025
T-Nut for subs. insertion, with spring F, M6	1	4.3 g	1.324.FM6

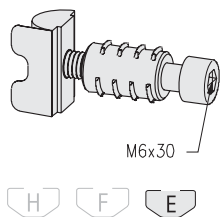

Description	Pcs.	Weight	Article-No.
Bayonet type connector E, with T-Nut (spring) E		25.5 g	1.25.E324E

### Single parts

Notching case E for bayonet type connector	1	7.5 g	1.25.BE
Cap head screw DIN 912, M6×30	1	8.0 g	0.63.D00912.06030
T-Nut for subs. insertion, with spring E, M6	1	10.0 g	1.324.EM6

### with T-slot nut

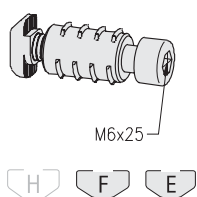

Description	Pcs.	Weight	Article-No.
Bayonet type connector E, with T-slot nut F		16.2 g	1.25.E3410F

### Single parts

Notching case E for bayonet type connector	1	7.5 g	1.25.BE
Cap head screw DIN 912, M6×25	1	7.0 g	0.63.D00912.06025
T-slot nut F, M6	1	1.7 g	1.34.10FM6

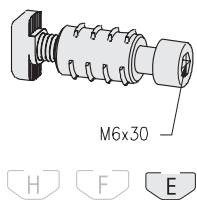

Description	Pcs.	Weight	Article-No.
Bayonet type connector E, with T-slot nut E		18.5 g	1.25.E3410E

### Single parts

Notching case E for bayonet type connector	1	7.5 g	1.25.BE
Cap head screw DIN 912, M6×30	1	8.0 g	0.63.D00912.06030
T-slot nut E, M6	1	3.0 g	1.34.10EM6

### Socket pin

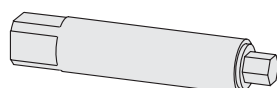

Description	Weight	Article-No.
Socket pin for notching case E	47.0 g	1.25.WZ1

**Bayonet type connector extension**

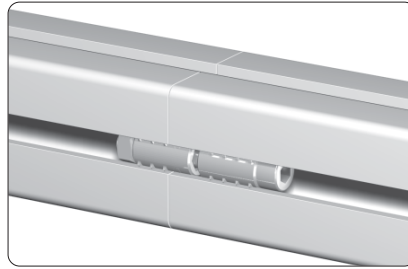

**Application**

Connection without profile machining.

**Mounting example**

**Pre-mounting of the notching case**  
(↔ Bayonet type connector, 113)



insert the cap head screw and the hexagonal nut into the slot

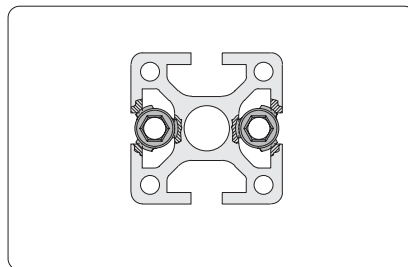

end position of the notching cases

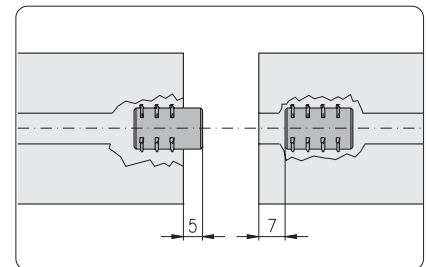

position of the notching cases

**Final assembly**

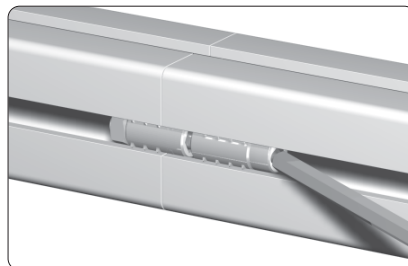

join the profiles and tighten the T-slot nut

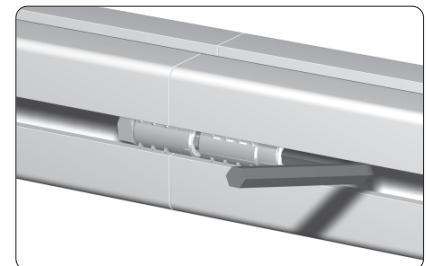

final tightening with socket spanner

**Technical data**

material: steel  
surface: galvanised

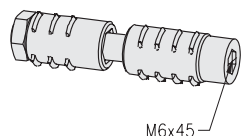

Description	Pcs.	Weight	Article-No.
Bayonet type connector E, extension		28.1 g	1.25.15.EV0
<b>Single parts</b>			
Notching case E for bayonet type connector	1	7.5 g	1.25.BE
Notching case E for bayonet type connector, extension	1	7.5 g	1.25.BEV0
Cap head screw DIN 912, M6x45	1	11.0 g	0.63.D00912.06045
Hexagonal nut, M6	1	2.1 g	0.61.D00934.06

**Cross connector**



**Application**

- quick assembly
- connection without profile machining

**Technical data**

Lower section, upper section, bolt,  
screw:  
material: steel  
surface: galvanised

**Assembly**

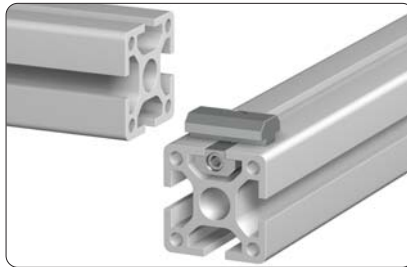

Push the lower section of the cross connector into the slot of the first profile

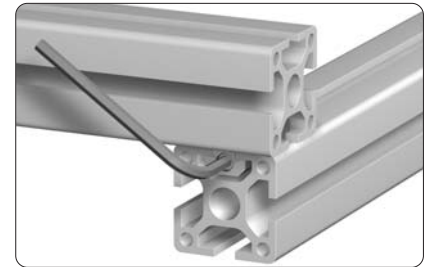

Slide the slot of the second profile onto the upper section, position the profiles and tighten the connector

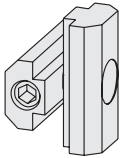

Description	Weight	Article-No.
Cross connector E3	53.5 g	1.25.41.E3
Cross connector E4	55.0 g	1.25.41.E4

**Clamping connector 40E**



**Application**

- quick assembly
- connection without profile machining

**Technical data**

material: steel  
surface: galvanised

**Assembly**



**Fastening element**

Threaded insert M14/M8, 30, 1.35.1140830

Screw the threaded insert M14/M8, 30 into the core hole ↗ *Assembly reference 1.35*



Screw the clamping connector into the threaded insert



Slide the connector into the slot of the second profile, position the profiles and tighten the connector

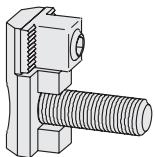

**Description**

Clamping connector 40E, single sided

**Weight**

34.4 g

**Article-No.**

1.25.61.40E

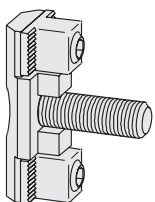

**Description**

Clamping connector 40E, double sided

**Weight**

43.9 g

**Article-No.**

1.25.62.40E

**Connection of 0-slot profiles**

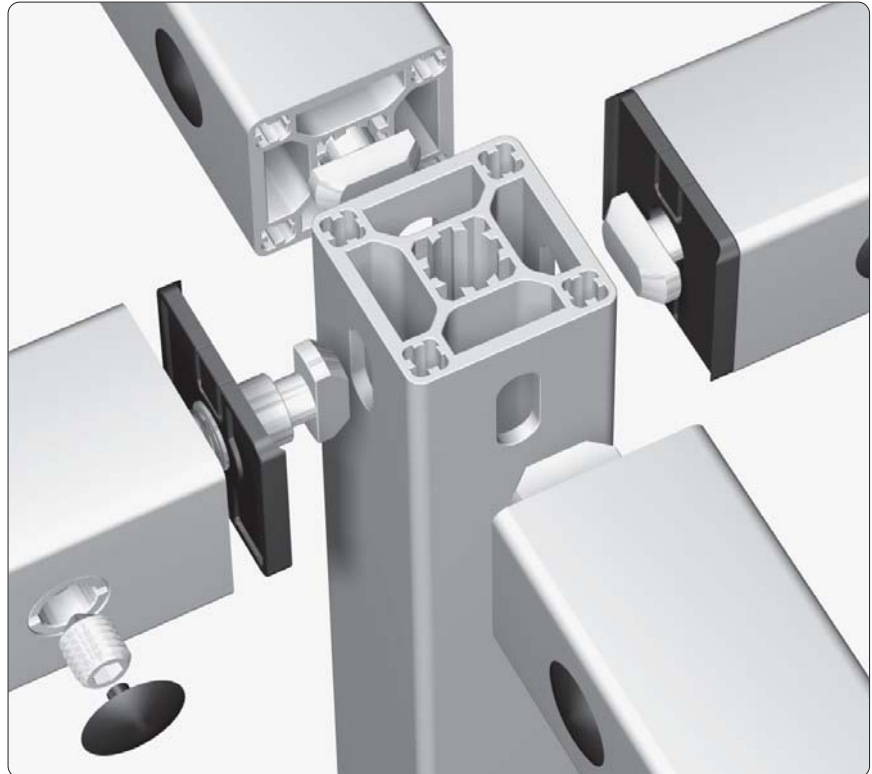

**Comments**  
Connector ↗ 1.2A

**Connector - drill dimensions**

without radius covers

PG 30	PG 40
Drill dimensions without radius covers	Drill dimensions without radius covers
Drill dimensions with radius covers	Drill dimensions with radius covers

with radius covers

↗ 1.43

**Cover plug**

for connector cross bushings

↗ 1.42

PG 30	PG 40



**Connection with standard connectors**

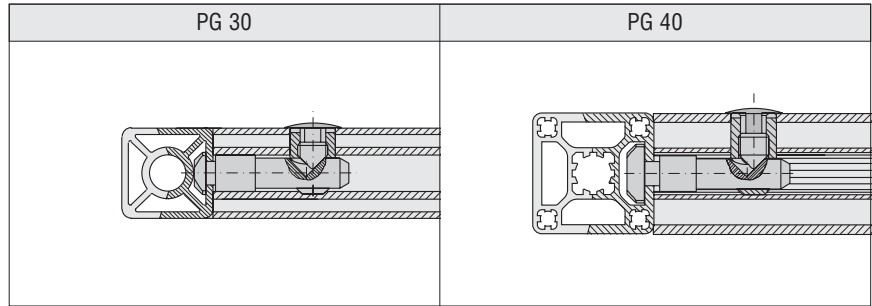

**Single parts**

Connector, standard 1.21.3F1 (V)  
 Connector, standard 90° 1.21.3F2 (V)

**Single parts**

Connector, standard 1.21.4E1 (V)  
 Connector, standard 90° 1.21.4E2 (V)

**Mounting variation for profiles with 1 connector**

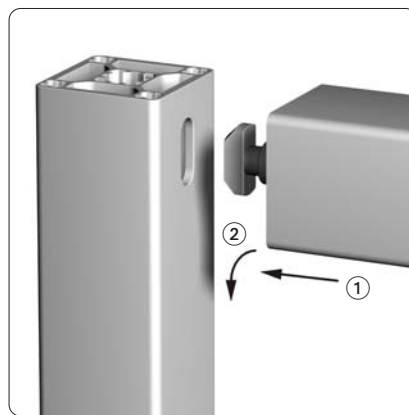

**Assembly**

- ① insert connector
- ② turn profile

**Fabrication measurements**

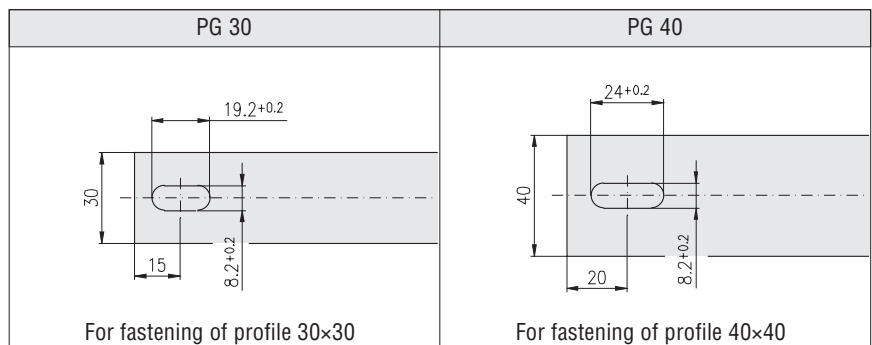

### Mounting variation

for profiles with 1 or more connectors, if the profile cannot be rotated

for high flexure load



#### Comments

Position of assembly: profiles flush on the top

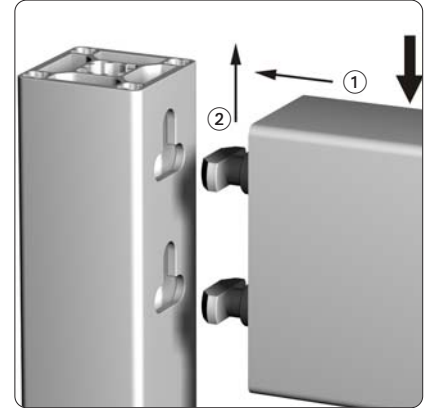

#### Assembly

- ① insert connector
- ② push profile to the top

### Fabrication measurements

PG 30	PG 40	PG 45
<p>For fastening of profile 30x30</p>	<p>For fastening of profile 40x40</p>	<p>For fastening of profile 45x45</p>
<p>For fastening of profile 30x60</p>	<p>For fastening of profile 40x80</p>	<p>For fastening of profile 45x90</p>
<p>For fastening of profile 60x60</p>	<p>For fastening of profile 80x80</p>	<p>For fastening of profile 90x90</p>

**Mounting variation**

for profiles with 1 or more connectors, if the profile cannot be rotated

for high sliding load



**Comments**

Position of assembly: profiles flush on the top

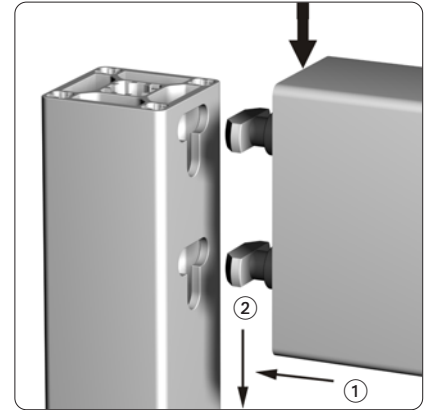

**Assembly**

- ① insert connector
- ② push profile to the bottom

**Fabrication measurements**

PG 30	PG 40	PG 45
<p>For fastening of profile 30x30</p>	<p>For fastening of profile 40x40</p>	<p>For fastening of profile 45x45</p>
<p>For fastening of profile 30x60</p>	<p>For fastening of profile 40x80</p>	<p>For fastening of profile 45x90</p>
<p>For fastening of profile 60x60</p>	<p>For fastening of profile 80x80</p>	<p>For fastening of profile 90x90</p>

## Connection with screw-type connector

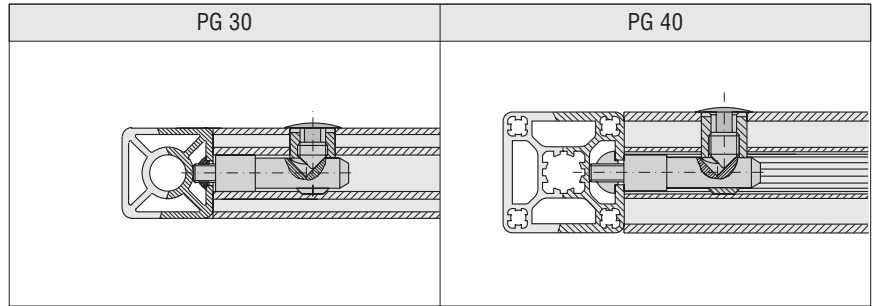

### Single parts

- Screw-type connector 1.21.3S1M8/7 (V)
- T-Nut 1.324.FM8 (V)

### Single parts

- Screw-type connector 1.21.4S1M8/11 (V)
- T-Nut 1.324.EM8 (V)

## Fabrication measurements

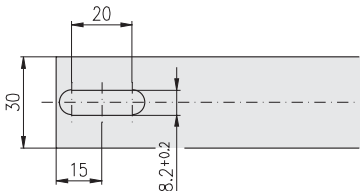
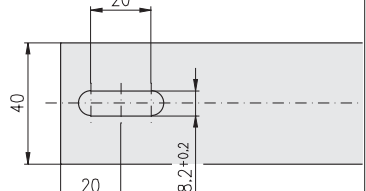
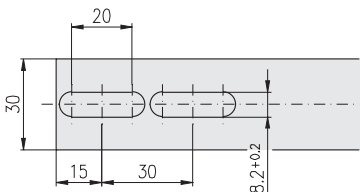
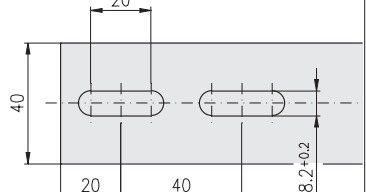
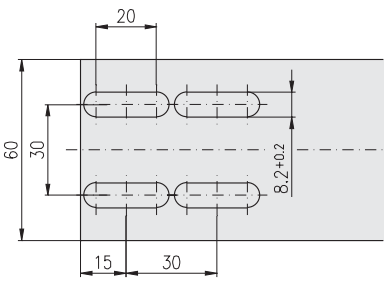
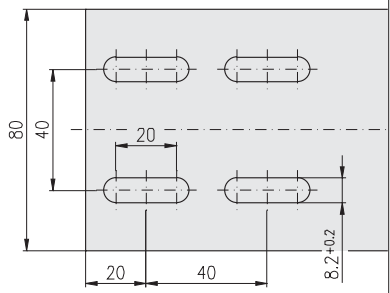
PG 30	PG 40
 <p>For fastening of profile 30×30</p>	 <p>For fastening of profile 40×40</p>
 <p>For fastening of profile 30×60</p>	 <p>For fastening of profile 40×80</p>
 <p>For fastening of profile 60×60</p>	 <p>For fastening of profile 80×80</p>

## Connection with DIN-Screw

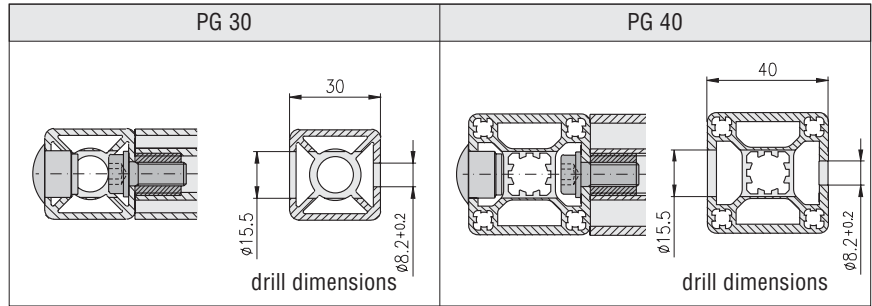

### Single parts

- Threaded insert M14/M8 1.35.1140815
- Cap head screw DIN 6912, M8×20 0.63.D06912.08020
- Washer, DIN 433 - 8.4 0.62.D00433.08,4
- Cover plug Ø15 1.42.6114.x

## Fabrication measurements

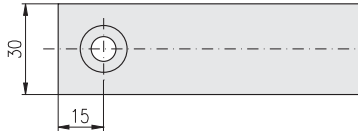
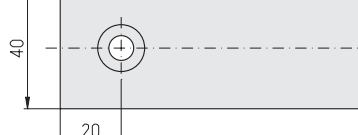
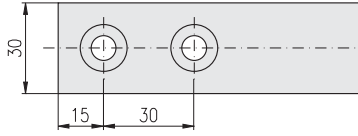
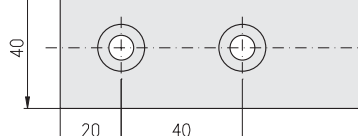
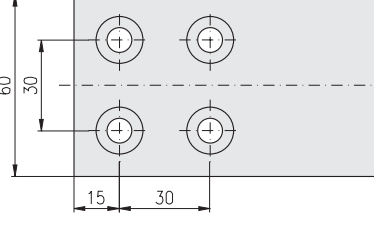
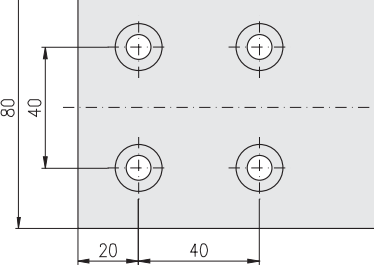
PG 30	PG 40
 <p>For fastening of profile 30×30</p>	 <p>For fastening of profile 40×40</p>
 <p>For fastening of profile 30×60</p>	 <p>For fastening of profile 40×80</p>
 <p>For fastening of profile 60×60</p>	 <p>For fastening of profile 80×80</p>

## Connection of profiles 40, round

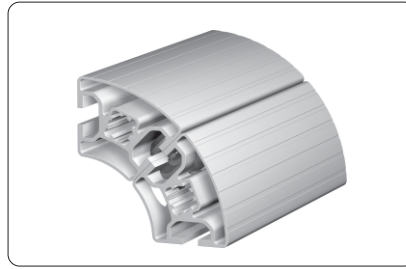

Drill dimensions for profiles 40, round			
30°		45°	
60°		90°	

## Calculation formulas for polygons

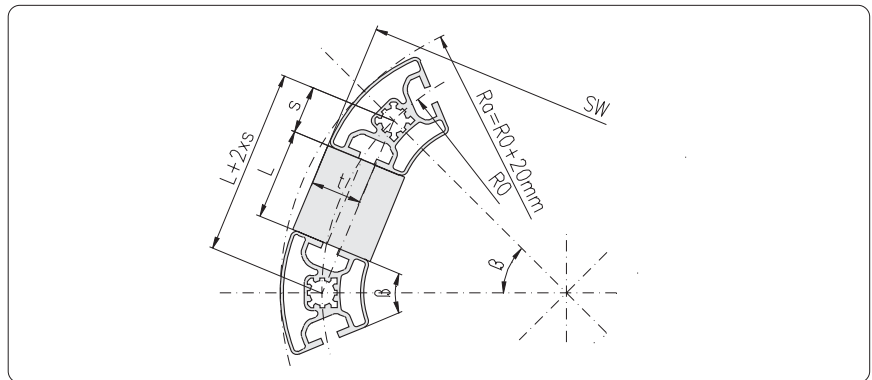

known	searched	Profile 40, round 30° ( $\beta = 30^\circ$ )	Profile 40, round 45° ( $\beta = 45^\circ$ )	Profile 40, round 60° ( $\beta = 60^\circ$ )
		t = 22.04 s = 15.53	t = 24.57 s = 22.96	t = 28.04 s = 30.00
$R_0$	L =	$R_0 \times 0.51764 - 31.06$	$R_0 \times 0.76537 - 45.92$	$R_0 - 60$
$R_a$	L =	$(R_a - 20) \times 0.51764 - 31.06$	$(R_a - 20) \times 0.76537 - 45.92$	$R_a - 80$
SW	L =	$\frac{SW - 44.08}{\sqrt{3.73205}} \times 0.51764 - 31.06$	$\frac{SW - 49.14}{\sqrt{3.4142}} \times 0.76537 - 45.92$	$\frac{SW - 56.08}{\sqrt{3}} - 60$
SW	$R_0 =$	$\frac{SW - 44.08}{\sqrt{3.73205}}$	$\frac{SW - 49.14}{\sqrt{3.4142}}$	$\frac{SW - 56.08}{\sqrt{3}}$
SW	$R_a =$	$\frac{SW - 44.08}{\sqrt{3.73205}} + 20$	$\frac{SW - 49.14}{\sqrt{3.4142}} + 20$	$\frac{SW - 56.08}{\sqrt{3}} + 20$
$R_0$	SW =	$\sqrt{(R_0 \times 2)^2 - (R_0 \times 0.51764)^2} + 44.08$	$\sqrt{(R_0 \times 2)^2 - (R_0 \times 0.76537)^2} + 49.14$	$(R_0 \times 2)^2 - R_0^2 + 56.08$
$R_a$	SW =	$\sqrt{((R_a - 20) \times 2)^2 - ((R_a - 20) \times 0.51764)^2} + 44.08$	$\sqrt{((R_a - 20) \times 2)^2 - ((R_a - 20) \times 0.76537)^2} + 49.14$	$((R_a - 20) \times 2)^2 - R_a^2 + 56.08$

Subsequent mounting of profiles

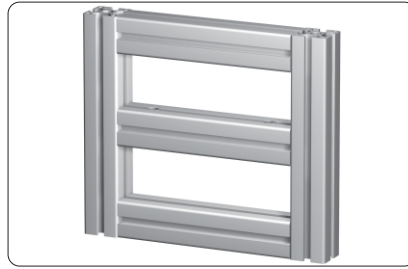

Step by step instruction for subsequent mounting of profiles with two standard connections for all profile groups

For the subsequent mounting of the profile:

1. Mill on both ends a slot size of 6x8 mm.

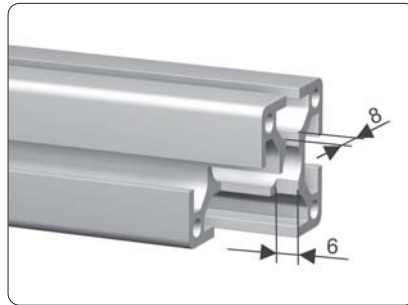

2. Mount connector and fix anchor in front position with setscrew.

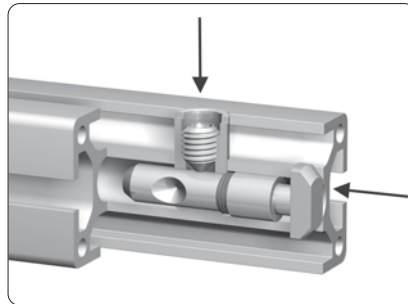

3. Mount profile.



4. Loosen setscrew.  
Due to the compressing spring the anchor is pushed into the slot.  
Turn anchor by 90° with screw driver.  
Fasten setscrew.



Connection of MayTec with other profile systems

Form H

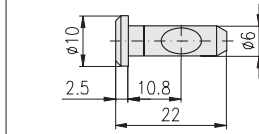

Form H

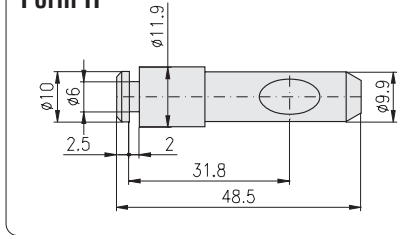

Form F

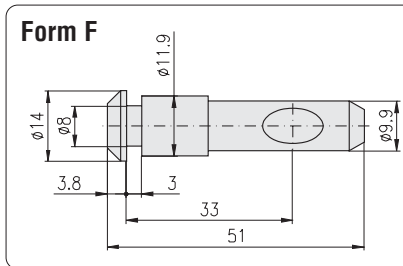

Form E

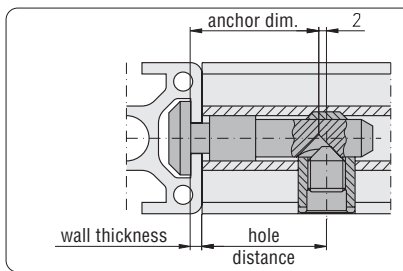
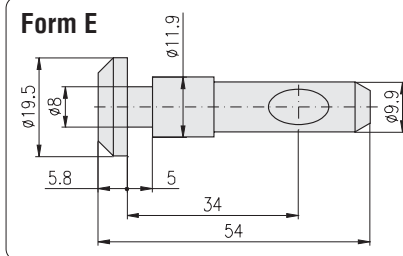

MayTec profiles can easily be combined with other profile systems. Two points have to be considered when combining with other profiles:

**1. Anchor head-form and size**

The MayTec system provides 3 anchor head sizes. If any of the sizes don't fit into the slots of other profile systems, the anchor head can be made to fit as required.

**2. Hole distance**

During the machining of the cross bore the hole distance has to match the wall thickness of the profile.

hole distance =  
 anchor dim. - wall thickness + 2 mm



### Torque tightening values for connector setscrew

PG	Slot	Setscrew special execution	Torque value	
			recommended	max.
20	H	M6×8	5.0 Nm	6.0 Nm
	F	M8×10	15.0 Nm	20.0 Nm
30	F	M10×12	25.0 Nm	30.0 Nm
40	E	M10×12	30.0 Nm	40.0 Nm
45	E	M10×12	30.0 Nm	40.0 Nm
50	E	M10×12	30.0 Nm	40.0 Nm
60	E	M10×12	30.0 Nm	40.0 Nm

### Comments

The max. tightening values are only valid for the MayTec setscrew and can not be reached by the usual commercial quality standard.

### Tension load

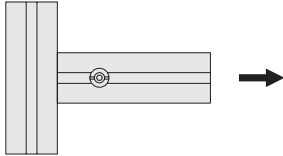

PG	Slot	max. Tensile strength			
		Connector		T-Nut	
		Standard	Universal		
20	H	-	1,500 N	M4	4,000 N
	F	5,000 N	6,000 N	M8	8,000 N
30	F	5,000 N	6,000 N	M8	8,000 N
40	E	10,000 N	12,000 N	M8	12,000 N
45	E	15,000 N	18,000 N	M8	20,000 N
50	E	15,000 N	18,000 N	M8	20,000 N
60	E	15,000 N	18,000 N	M8	20,000 N

### Comments

All values given have been tested with pre-tension of the connectors and maximum torque value and refer to the connection of two identical profiles.

### Slide load

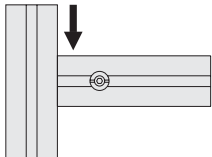

### Flexure load

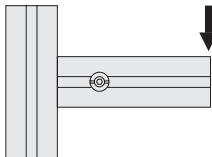

PG	Profile	Slot	max. Slide strength			max. Flexure strength
			Connector			
			Pcs.	Standard	E-connector	Standard
20	20×20	H	1	1,500 N	-	50 Nm
	20×40		2	3,000 N	-	150 Nm
	40×40		4	6,000 N	-	300 Nm
	20×30	F	1	5,000 N	7,500 N	65 Nm
30	30×30	F	1	5,000 N	7,500 N	100 Nm
	30×50		1	5,000 N	7,500 N	160 Nm
	30×60		2	10,000 N	15,000 N	300 Nm
	30×100, 5F		2	10,000 N	15,000 N	640 Nm
	30×100, 8F		3	15,000 N	22,500 N	960 Nm
	30×150, 8F		3	15,000 N	22,500 N	900 Nm
	60×60 angle		3	15,000 N	22,500 N	400 Nm
	60×60		4	20,000 N	30,000 N	600 Nm
	30×150		E	2	12,000 N	18,000 N
40	40×40	E	1	6,000 N	9,000 N	250 Nm
	40×60		1	6,000 N	9,000 N	500 Nm
	40×80		2	12,000 N	18,000 N	750 Nm
	40×120		3	18,000 N	27,000 N	2,000 Nm
	40×160		4	24,000 N	36,000 N	3,750 Nm
	80×80 angle		3	18,000 N	27,000 N	1,000 Nm
	80×80, 8E		4	24,000 N	36,000 N	1,500 Nm
	80×120		6	36,000 N	54,000 N	2,250 Nm
	120×120		8	48,000 N	72,000 N	3,250 Nm
	80×160		8	48,000 N	72,000 N	3,750 Nm
45	45×45	E	1	6,000 N	9,000 N	360 Nm
	45×60		1	6,000 N	9,000 N	530 Nm
	45×90		2	12,000 N	18,000 N	1,080 Nm
	90×90		4	24,000 N	36,000 N	2,160 Nm
50	50×50	E	1	6,000 N	9,000 N	400 Nm
	50×100, 6E		2	12,000 N	18,000 N	1,200 Nm
	50×100, 8E		3	18,000 N	27,000 N	2,000 Nm
	50×150		3	18,000 N	27,000 N	3,200 Nm
	100×100		4	24,000 N	36,000 N	2,400 Nm
	100×200		8	48,000 N	72,000 N	12,000 Nm
	100×300		12	72,000 N	108,000 N	19,000 Nm
60	60×60	E	1	6,000 N	9,000 N	480 Nm
	60×90		2	12,000 N	18,000 N	1,200 Nm

Retaining plates



**Technical data**  
 material: steel  
 surface: galvanised

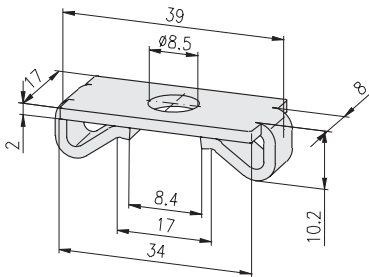

Description	Weight	Article-No.
Retaining plate	13 g	1.29.11140

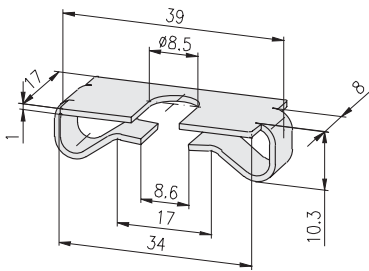

Description	Weight	Article-No.
Retaining plate for connector	11 g	1.29.11240

**Anti-twist devices**



**Application**

In the case of high torque forces with connections of one connector only, twisting can be prevented by mounting 1 or 2 anti-twist devices.

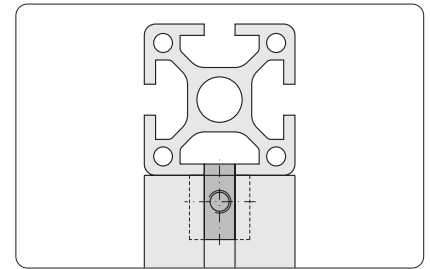
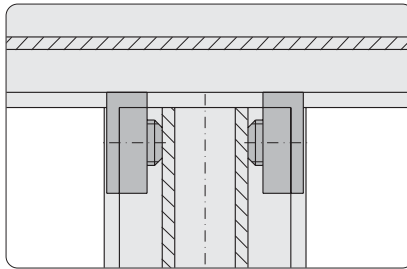

The nose of the anti-twist device fits into the basic profile.

**Technical data**

material: steel  
 surface: galvanised  
 max. moment of torque:  $M_{A, max}$

**Fastening elements**

F-slot:  
 Setscrew ISO 4026 M6×8 0.66.104026.06008  
 E-slot:  
 Setscrew ISO 4026 M6×12 0.66.104026.06012

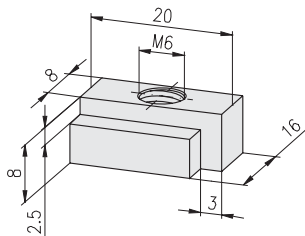
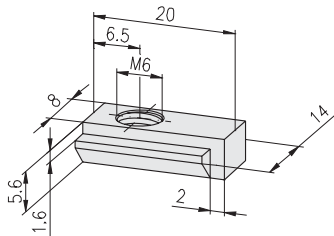

Description	G	$M_{A, max}$	Weight	Article-No.
Anti-twist device F	M6	10 Nm	7.3 g	1.29.321.FM6

Description	G	$M_{A, max}$	Weight	Article-No.
Anti-twist device E	M6	10 Nm	14 g	1.29.321.EM6

**Anti-twist devices  
for subsequent insertion**



**Application**

In the case of high torque forces with connections of one connector only, twisting can be prevented by mounting 1 or 2 anti-twist devices.

- for subsequent insertion

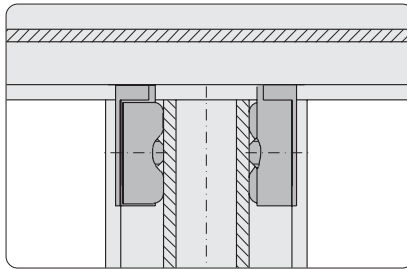

The nose of the anti-twist device fits into the basic profile.

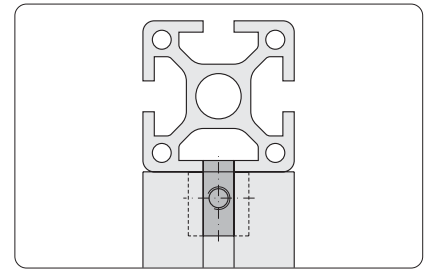

**Technical data**

material: steel  
 surface: galvanised  
 max. moment of torque:  $M_{A, max}$

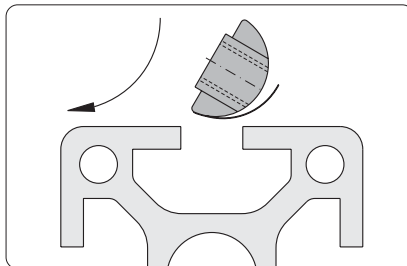

Insert front-sided and rotate

**Fastening elements**

F-slot:  
 Setscrew ISO 4026 M6×8      0.66.104026.06008  
 E-slot:  
 Setscrew ISO 4026 M6×12      0.66.104026.06012

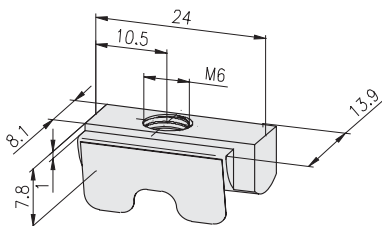
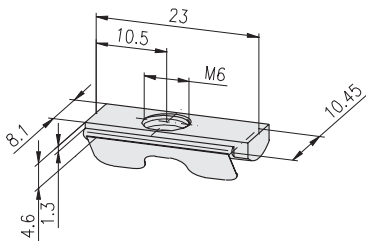

Description	G	$M_{A, max}$	Weight	Article-No.
Anti-twist device F	M6 for subsequent insertion	10 Nm	7.3 g	1.29.324.FM6

Description	G	$M_{A, max}$	Weight	Article-No.
Anti-twist device E	M6 for subsequent insertion	10 Nm	14 g	1.29.324.EM6

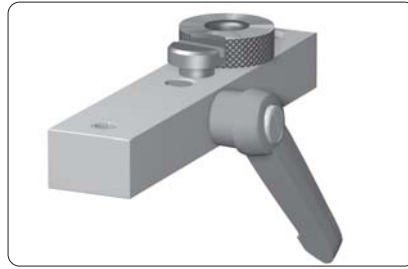
**Clamping levers**

Clamping lever for drill jigs

**Application**

Any MayTec connector can be equipped with a clamping lever.  
For frequent opening and closing

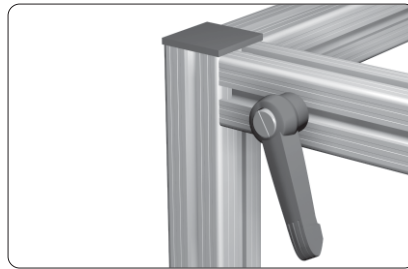

Clamping lever for connector

**Technical data**

clamping handle: PA-glass-fiber reinf.  
clamping lever: with ratchet lever handle  
annular gear: die casted zinc steel  
thread: steel

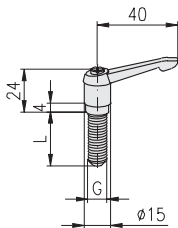
**Clamping levers 40**  
for connector

Description	G	L	Weight	Article-No.
Clamping lever 40 for connector	M6	20	17 g	1.29.500620
Clamping lever 40 for connector	M8	20	21 g	1.29.500820
Clamping lever 40 for connector	M10	20	24 g	1.29.501020
Clamping lever 40 for connector	M10	30	29 g	1.29.501030

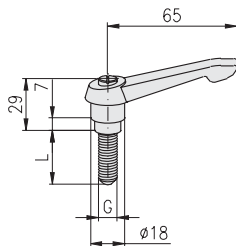



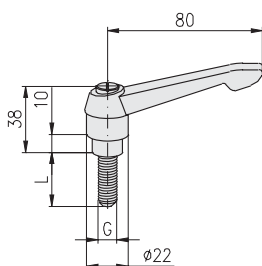





**Clamping levers 65**  
for connector

Description	G	L	Weight	Article-No.
Clamping lever 65 for connector	M6	20	36 g	1.29.650620
Clamping lever 65 for connector	M8	20	41 g	1.29.650820
Clamping lever 65 for connector	M10	20	44 g	1.29.651020
Clamping lever 65 for connector	M10	30	49 g	1.29.651030











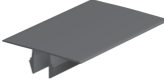

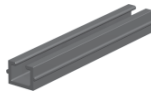





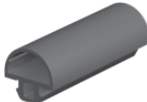

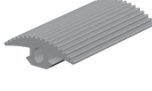
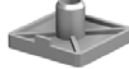





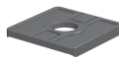
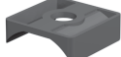





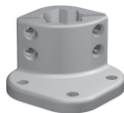









**Clamping levers 80**  
for connector

Description	G	L	Weight	Article-No.
Clamping lever 80 for connector	M8	20	64 g	1.29.800820
Clamping lever 80 for connector	M10	20	65 g	1.29.801020
Clamping lever 80 for connector	M10	30	70 g	1.29.801030

**1.3 Fastening elements**

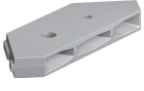
							
Threaded plates ↗ 135	Threaded plates for subs. insertion ↗ 136	Threaded plates heavy ↗ 137	T-Nuts ↗ 138	T-Nuts for subs. insertion ↗ 138-140	Spring-nuts front-sided insertion ↗ 141	T-slot nuts ↗ 142	Rhomboid T-slot nuts with self-locking ↗ 143
							
T-Bolts front-sided insertion ↗ 144	Threaded inserts ↗ 145-146	Press-fit threaded inserts ↗ 147-148					

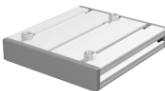
**1.4 Installation accessories**

							
Cover profiles ↗ 149	Cover profiles ↗ 149	Reducing profiles ↗ 150	Combination profiles ↗ 151	Combination profiles ↗ 152	Combination profiles for sliding profiles ↗ 154	Guide profile for sliding profile ↗ 155	Framing profiles one piece ↗ 156
							
Wedge profiles ↗ 157	Sponge rubber round cords ↗ 158-159	Sealing profile ↗ 160	Framing profiles ↗ 161-162	Rubber cover-profiles ↗ 163	Cover caps for profiles ↗ 164-166	Cover cap Ø48 for hand rail profile ↗ 166	Cover plugs for cross bushings ↗ 167
							
Cover plugs domed for cross bushings ↗ 167	Cover caps for tubes ↗ 168	Cover caps for screw bores ↗ 168	Radius covers ↗ 169-170	Radius compensations ↗ 171	Floor levelling screws ↗ 172	Levelling foot PA 20 ↗ 172	Hand adjustable feet ↗ 173
							
Levelling feet ↗ 174	Adjustable tilt-feet ↗ 175-179	Angular adjusting feet ↗ 180	Base foot ↗ 181	Base feet ↗ 182-186	Base angle ↗ 187	Stacking foot ↗ 187	Fixed castors ↗ 188
							
Swivel castors ↗ 189	Swivel castors lockable ↗ 189	Locking castors ↗ 190	Angles ↗ 192	Angles PA ↗ 193	Angles GD-Zn ↗ 194-199	Angles GD-Al ↗ 200	Angles Alu ↗ 201
							
Swivel angles straight design ↗ 202	Swivel angles ↗ 202-203	Cross connection plates ↗ 203	Base plates ↗ 204	Floor mounting plate ↗ 205	Mounting plates ↗ 206	Floor plate ↗ 206	Connection plates ↗ 207

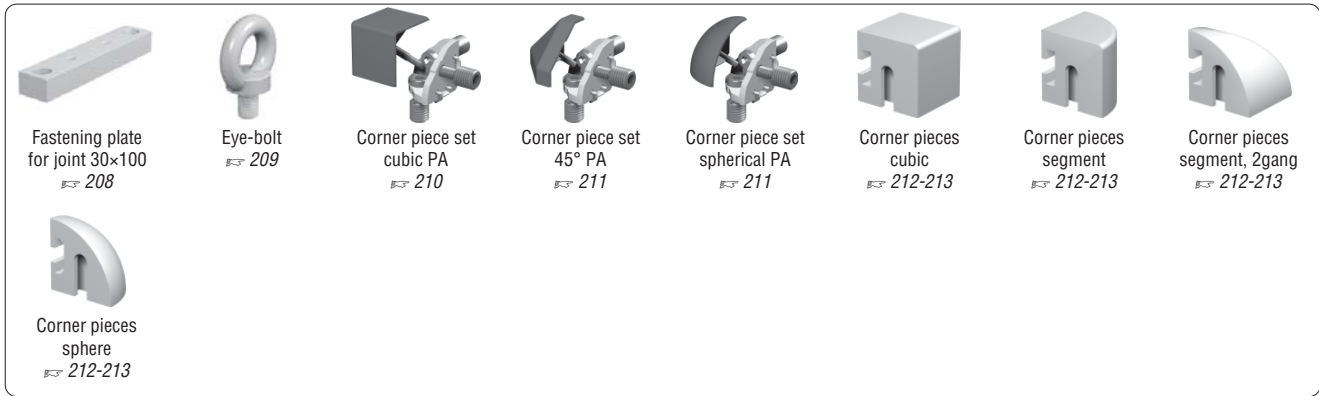



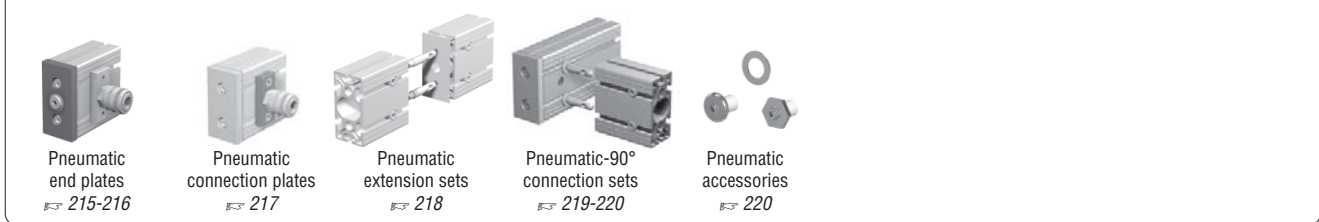



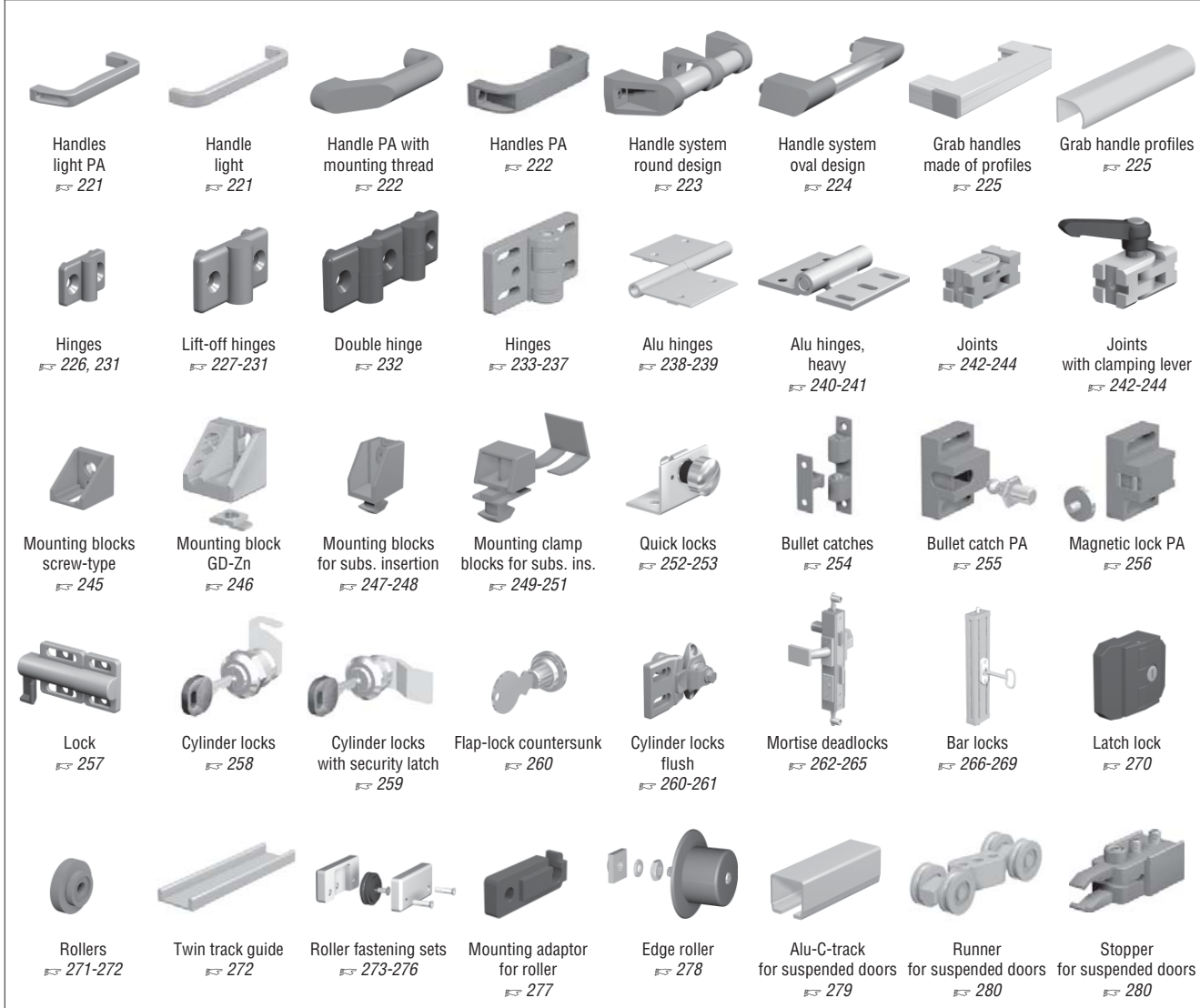

1.5 Pneumatic accessories



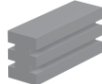









1.6 Additional accessories





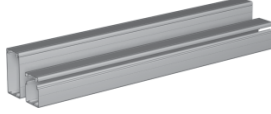

							
Bottom guide for suspended doors ↔ 280	Frame guide for suspended doors ↔ 280	Rubber door stop for suspended doors ↔ 280	Runner for sliding suspended doors ↔ 281	Slot rollers ↔ 283	Sliding blocks ↔ 285	T-Nut sliding blocks ↔ 286	Eco-Slides ↔ 287-290
							
Hanging bracket ↔ 291	Suspended glider ↔ 292						







**1.7 Electrical accessories**

							
Potential equalisation ↔ 293	Ground connections ↔ 294	Cable and hose clamp ↔ 295	Block for cable binder ↔ 296	Installation rings ↔ 297	Mounting set for 19" profile ↔ 298	Safety switches ↔ 299-300	Safety interlocking-mountings ↔ 301-305
							
Sensor brackets ↔ 306	Electrical installation trunking ↔ 307-310	Electrical installation trunkings ↔ 311-313					

**1.8 Panel elements**

				
Corner elements for wire net m. profile ↔ 314	Corner element 33 for wire net m. prf. 33x10 ↔ 315	Mounting sockets ↔ 316	Panel elements ↔ 317-320	Wire nets, grid ↔ 321-322

**1.9 Tools**

						
Button head screws ↔ 323	Press in device for knurled cross bushing ↔ 324	Tx screw driver ↔ 325	Drill jigs ↔ 327, 329	Drills ↔ 328, 330-331	Milling cutters ↔ 328, 330-331	Screw taps ↔ 332-333



**Threaded plates**

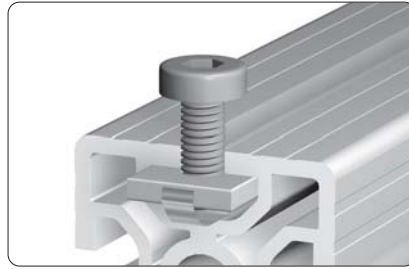

Fixed into position with leaf spring

**Application**

Fastening element for screw-type connections

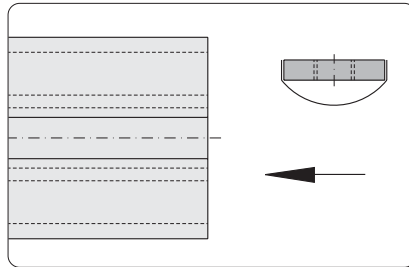

**Assembly**

Insert from end

**Technical data**

material: steel  
 surface: galvanised  
 max. moment of torque:  $M_{A, \max}$

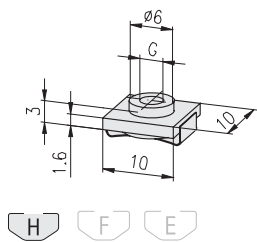

Description	G	$M_{A, \max}$	Weight	Article-No.
Threaded plate H	M3	1.3 Nm	1.5 g	1.31.HM3
Threaded plate H	M4	2.0 Nm	1.3 g	1.31.HM4
Threaded plate H	M5	2.0 Nm	1.2 g	1.31.HM5

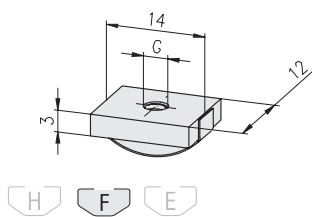

Description	G	$M_{A, \max}$	Weight	Article-No.
Threaded plate F	M3	1.3 Nm	3.9 g	1.31.FM3
Threaded plate F	M4	3.0 Nm	3.7 g	1.31.FM4
Threaded plate F	M5	5.0 Nm	3.6 g	1.31.FM5
Threaded plate F	M6	7.0 Nm	3.3 g	1.31.FM6

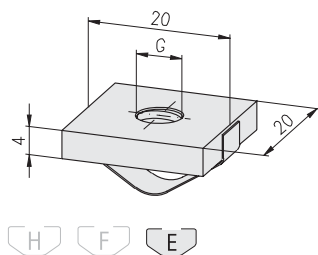

Description	G	$M_{A, \max}$	Weight	Article-No.
Threaded plate E	M3	1.3 Nm	12.0 g	1.31.EM3
Threaded plate E	M4	3.0 Nm	11.8 g	1.31.EM4
Threaded plate E	M5	5.0 Nm	11.6 g	1.31.EM5
Threaded plate E	M6	8.0 Nm	11.3 g	1.31.EM6
Threaded plate E	M8	15.0 Nm	11.0 g	1.31.EM8

**Threaded plates  
for subsequent insertion**

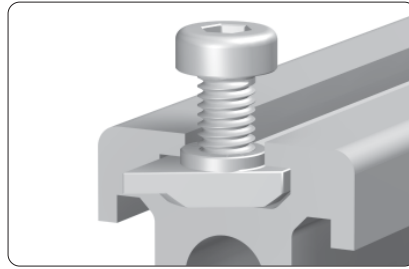

**Application**  
Fastening element for screw-type connections

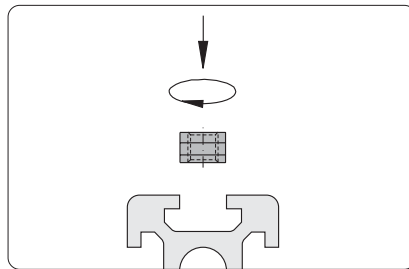

**Assembly**  
Insert frontally and turn 60°

**Technical data**

material: steel  
 surface: galvanised  
 max. moment of torque:  $M_{A, \max}$

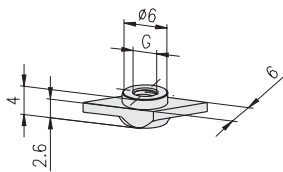

Description	G	$M_{A, \max}$	Weight	Article-No.
Threaded plate for subsequent insertion H	M3	1.3 Nm	0.90 g	1.314.HM3
Threaded plate for subsequent insertion H	M4	2.0 Nm	0.85 g	1.314.HM4
Threaded plate for subsequent insertion H	M5	2.0 Nm	0.80 g	1.314.HM5

**Threaded plates  
heavy**

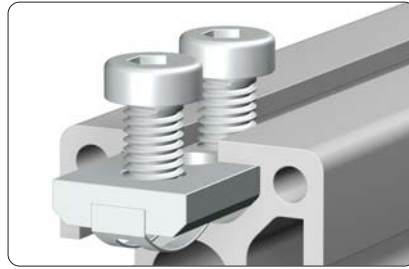

Fixed into position with leaf spring

**Application**

- Fastening element for
- screw-type connections
  - hinges, heavy, type 20, 21, 22, 23, 31

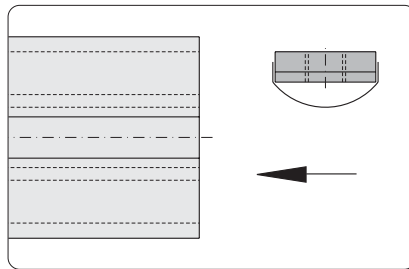

**Assembly**

Insert from end

**Technical data**

material: steel  
 surface: galvanised  
 max. moment of torque:  $M_{A, \max}$

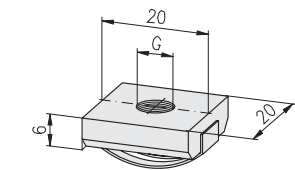

Description	G	$M_{A, \max}$	Weight	Article-No.
Threaded plate, heavy E	M6	10.0 Nm	17.2 g	1.316.EM6
Threaded plate, heavy E	M8	26.0 Nm	16.3 g	1.316.EM8

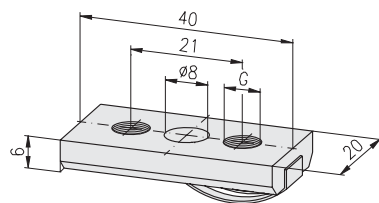

Description	G	$M_{A, \max}$	Weight	Article-No.
Threaded plate, heavy E	2×M6	10.0 Nm	33.8 g	1.316.E2M6
Threaded plate, heavy E	2×M8	26.0 Nm	32.0 g	1.316.E2M8

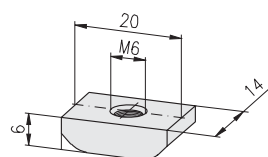

**Application**

Fastening element for  
 ST-Connector Type 4 ↗ 1.2D  
 Application sample ↗ Eco-Slide 1.67

Description	G	$M_{A, \max}$	Weight	Article-No.
Threaded plate, heavy E	M6	10.0 Nm	12.4 g	1.317.EM6

**T-Nuts with spring**

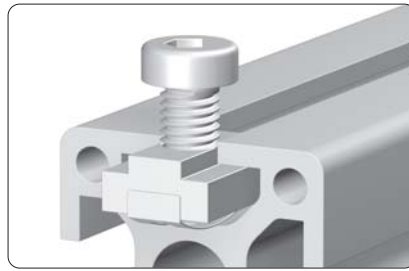

Fixing with leaf spring

**Application**

Fastening element for screw-type connections

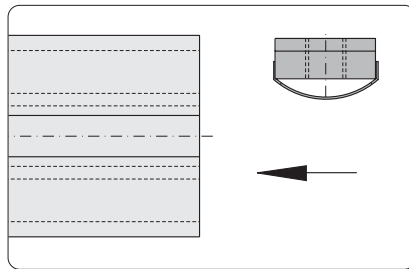

Insert from end

**Assembly**

Insert from end

**Technical data**

material: steel  
 surface: galvanised  
 max. moment of torque:  $M_{A, max}$

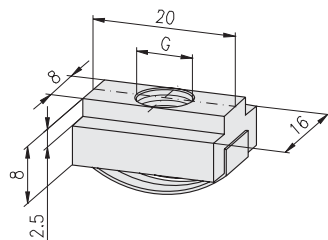
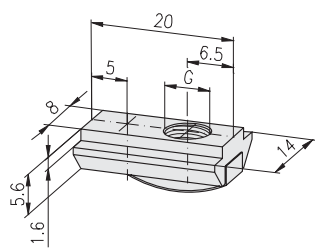

Description	G	$M_{A, max}$	Weight	Article-No.
T-Nut with spring F	M6	10 Nm	7.0 g	1.32.FM6
T-Nut with spring F	M8	26 Nm	6.6 g	1.32.FM8

Description	G	$M_{A, max}$	Weight	Article-No.
T-Nut with spring E	M6	10 Nm	15 g	1.32.EM6
T-Nut with spring E	M8	26 Nm	14 g	1.32.EM8

**T-Nuts for subsequent insertion, with spring ball**



Fixing with spring ball

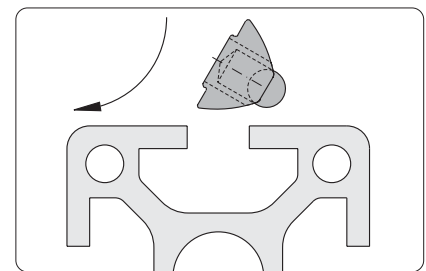

Insert front-sided and rotate

**Application**

Fastening element for screw-type connections

**Technical data**

material: steel  
 surface: galvanised  
 max. moment of torque:  $M_{A, max}$

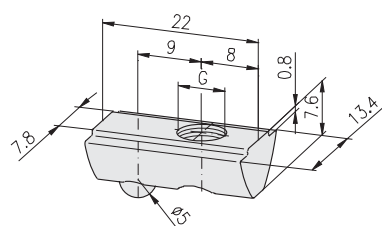

Description	G	$M_{A, max}$	Weight	Article-No.
T-Nut for subs. insertion, w. spring ball	E M4	3.0 Nm	10.4 g	1.323.EM4
T-Nut for subs. insertion, w. spring ball	E M5	5.0 Nm	10.2 g	1.323.EM5
T-Nut for subs. insertion, w. spring ball	E M6	10.0 Nm	9.9 g	1.323.EM6
T-Nut for subs. insertion, w. spring ball	E M8	26.0 Nm	9.6 g	1.323.EM8

**T-Nuts  
for subsequent insertion,  
with spring**

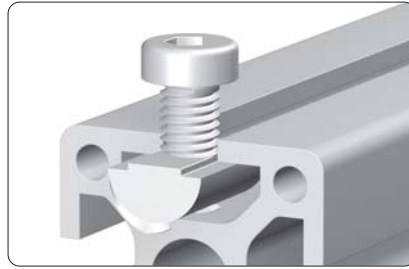

Fixing with leaf spring

**Application**

Fastening element for screw-type connections

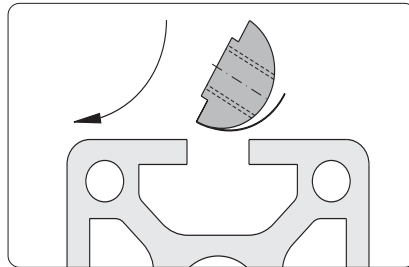

Insert front-sided and rotate

**Technical data**

Design steel:

- material: steel
- surface: galvanised

Design stainless:

- material: stainless steel 1.4305
- surface: pickled and passivated

max. moment of torque:  $M_{A, max}$

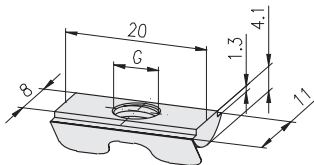

Description	G	Design	$M_{A, max}$	Weight	Article-No.
T-Nut for subs. ins., w. spring F	M3	steel	1.3 Nm	5.0 g	1.324.FM3
T-Nut for subs. ins., w. spring F	M4	steel	3.0 Nm	4.9 g	1.324.FM4
T-Nut for subs. ins., w. spring F	M5	steel	5.0 Nm	4.6 g	1.324.FM5
T-Nut for subs. ins., w. spring F	M6	steel	10.0 Nm	4.3 g	1.324.FM6
T-Nut for subs. ins., w. spring F	M8	steel	10.0 Nm	3.7 g	1.324.FM8
T-Nut for subs. ins., w. spring F	M6	stainless	10.0 Nm	4.3 g	1.324.FM6V
T-Nut for subs. ins., w. spring F	M8	stainless	10.0 Nm	3.7 g	1.324.FM8V

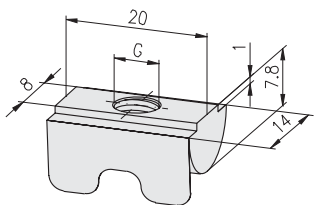

Description	G	Design	$M_{A, max}$	Weight	Article-No.
T-Nut for subs. ins., w. spring E	M3	steel	1.3 Nm	10.0 g	1.324.EM3
T-Nut for subs. ins., w. spring E	M4	steel	3.0 Nm	10.0 g	1.324.EM4
T-Nut for subs. ins., w. spring E	M5	steel	5.0 Nm	10.0 g	1.324.EM5
T-Nut for subs. ins., w. spring E	M6	steel	10.0 Nm	10.0 g	1.324.EM6
T-Nut for subs. ins., w. spring E	M8	steel	26.0 Nm	9.0 g	1.324.EM8
T-Nut for subs. ins., w. spring E	M5	stainless	5.0 Nm	10.0 g	1.324.EM5V
T-Nut for subs. ins., w. spring E	M6	stainless	10.0 Nm	10.0 g	1.324.EM6V
T-Nut for subs. ins., w. spring E	M8	stainless	26.0 Nm	9.0 g	1.324.EM8V

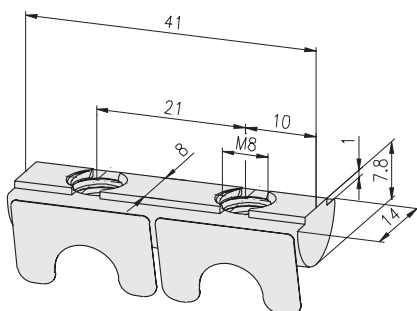

Fixing with leaf spring

**Application**

- Fastening element for
- screw-type connections
  - hinges, heavy, type 20, 21, 22, 23, 31

**Technical data**

material: steel  
 surface: galvanised  
 max. moment of torque:  $M_{A, max}$

Description	G	$M_{A, max}$	Weight	Article-No.
T-Nut for subs. ins., w. spring E	2×M8	26.0 Nm	20.3 g	1.324.E2M8.41

**T-Nuts  
for subsequent insertion,  
with spring**

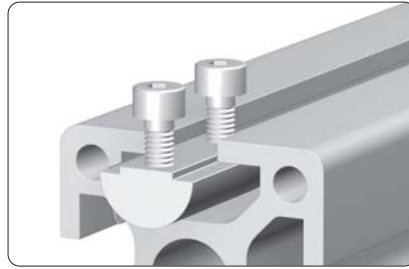

Fixing with leaf spring

**Application**

Fastening element for screw-type connections

**Technical data**

material: steel  
surface: galvanised  
max. moment of torque:  $M_{A, max}$

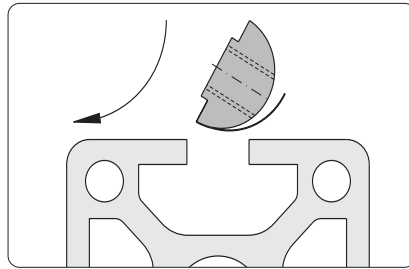

Insert front-sided and rotate

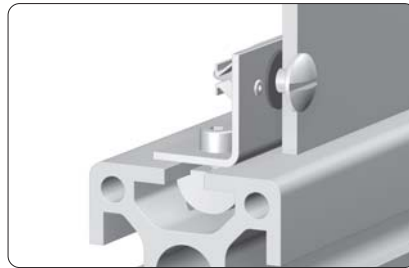

**Application**

Fastening element for mounting angle, quick lock  $\rightarrow$  252

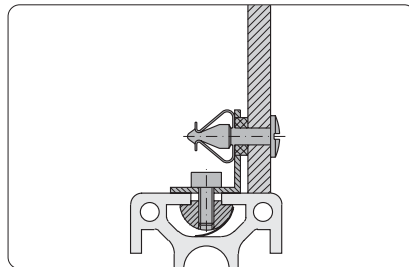
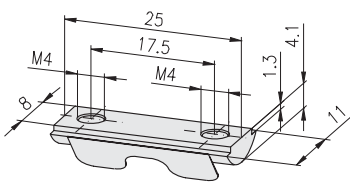

Fastening without washer

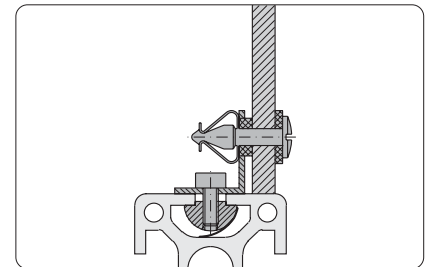

Fastening with washer

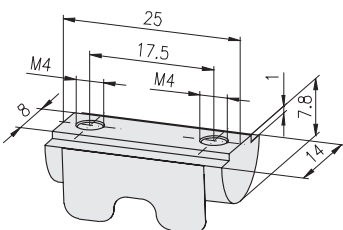

Description	G	$M_{A, max}$	Weight	Article-No.
T-Nut for subs. ins., w. spring F	2xM4	3.0 Nm	7.0 g	1.324.F2M4.25

Description	G	$M_{A, max}$	Weight	Article-No.
T-Nut for subs. ins., w. spring E	2xM4	3.0 Nm	12.0 g	1.324.E2M4.25

**Spring-nuts  
front-sided insertion**

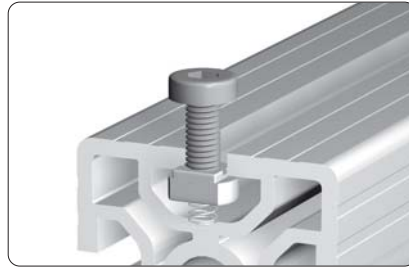

Fixing with compressing spring

**Application**

Fastening element for screw-type connections  
Applicable for small loads such as:

- enclosures
- electric switches

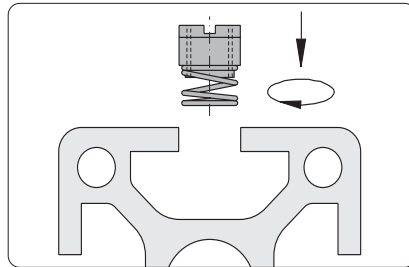

**Assembly**

Insert front-sided and turn 90°

**Technical data**

material: steel  
surface: galvanised  
max. moment of torque:  $M_{A, max}$

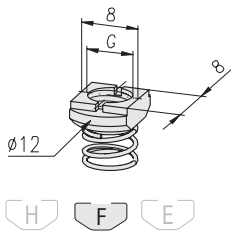

Description	G	$M_{A, max}$	Weight	Article-No.
Spring-nut F	M3	1.3 Nm	1.6 g	1.33.FM3
Spring-nut F	M4	3.0 Nm	1.5 g	1.33.FM4
Spring-nut F	M5	5.0 Nm	1.3 g	1.33.FM5
Spring-nut F	M6	8.0 Nm	1.1 g	1.33.FM6

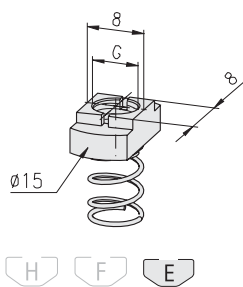

Description	G	$M_{A, max}$	Weight	Article-No.
Spring-nut E	M3	1.3 Nm	3.9 g	1.33.EM3
Spring-nut E	M4	3.0 Nm	3.7 g	1.33.EM4
Spring-nut E	M5	5.0 Nm	3.4 g	1.33.EM5
Spring-nut E	M6	10.0 Nm	3.0 g	1.33.EM6

T-slot nuts

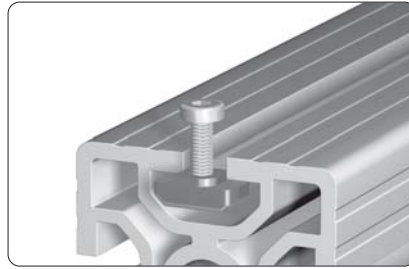

**Application**

Fastening element for screw-type connections

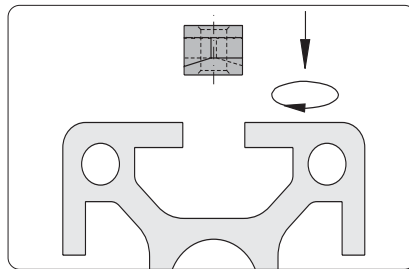

**Assembly**

Mount the T-slot nut onto the screw and insert into the slot

Rotate the screw with T-slot nut 90° inside and then fasten

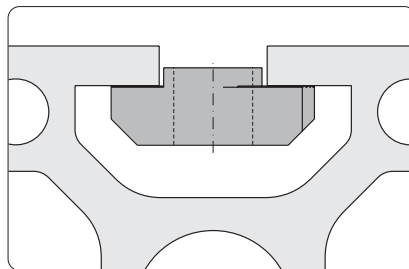

**Technical data**

material: GD-Zn  
max. moment of torque:  $M_{A, max}$

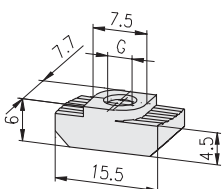
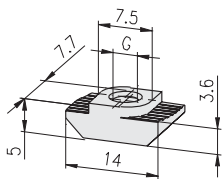

Description	G	Colour	$M_{A, max}$	Weight	Article-No.
T-slot nut F	M4	blue	3.0 Nm	2.4 g	1.34.10FM4
T-slot nut F	M5	black	5.0 Nm	2.0 g	1.34.10FM5
T-slot nut F	M6	yellow	10.0 Nm	1.7 g	1.34.10FM6

Description	G	Colour	$M_{A, max}$	Weight	Article-No.
T-slot nut E	M4	blue	3.0 Nm	3.6 g	1.34.10EM4
T-slot nut E	M5	black	5.0 Nm	3.2 g	1.34.10EM5
T-slot nut E	M6	yellow	10.0 Nm	3.0 g	1.34.10EM6



**Rhomboid T-slot nuts with self-locking**

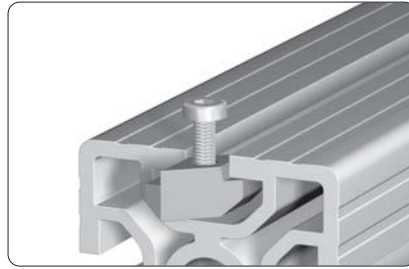

**Application**

For pre-assembly of threads in the profile slot

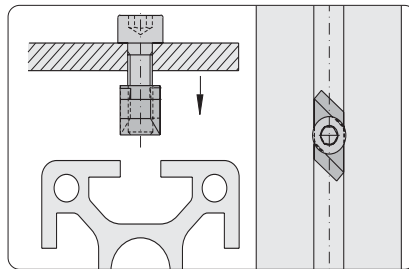

**Assembly**

Pre-assemble the rhomboid T-slot nut onto the screw, and insert into the slot

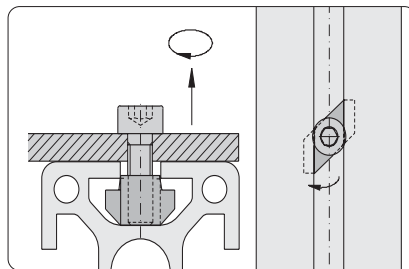

By tightening the screw, the rhomboid T-slot nut is turned 90° and jammed inside the slot with its conical flanks

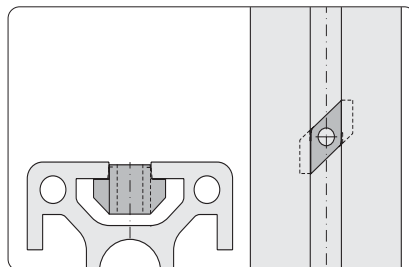

Even after loosening the screw, the rhomboid T-slot nut will remain wedged in place

**Technical data**

material: GD-Zn  
 surface: galvanised  
 max. moment of torque:  $M_{A, \max}$

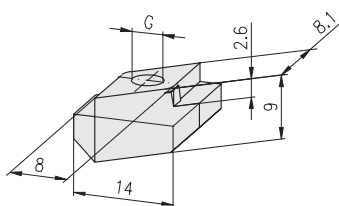

Description	G	$M_{A, \max}$	Weight	Article-No.
Rhomboid T-slot nut E	M3	1.3 Nm	6.5 g	1.34.20EM3
Rhomboid T-slot nut E	M4	3.0 Nm	6.2 g	1.34.20EM4
Rhomboid T-slot nut E	M5	5.0 Nm	5.9 g	1.34.20EM5
Rhomboid T-slot nut E	M6	10.0 Nm	5.5 g	1.34.20EM6

**T-Bolts  
front-sided insertion**

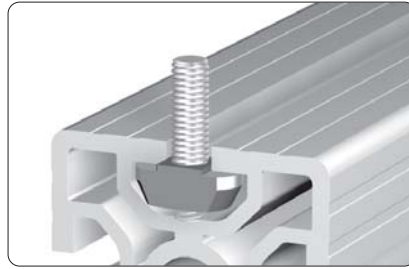

Fixing with compressing spring

**Application**

Fastening element for screw-type connections

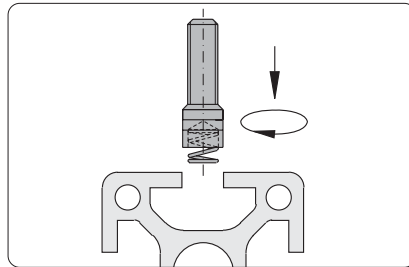

**Assembly**

Insert front-sided and turn 90°

**Technical data**

material: steel  
 surface: galvanised  
 max. moment of torque:  $M_{A, max}$

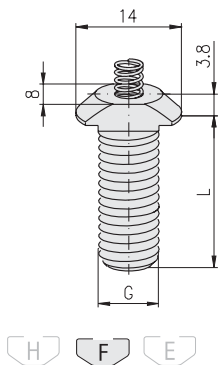

Description	G×L	$M_{A, max}$	Weight	Article-No.
T-Bolt F	M6×20	6 Nm	6.0 g	1.34.FM62
T-Bolt F	M6×30	6 Nm	7.0 g	1.34.FM63
T-Bolt F	M8×20	15 Nm	8.0 g	1.34.FM82
T-Bolt F	M8×30	15 Nm	11.2 g	1.34.FM83

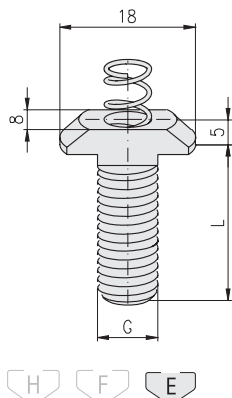

Description	G×L	$M_{A, max}$	Weight	Article-No.
T-Bolt E	M6×20	6 Nm	9.0 g	1.34.EM62
T-Bolt E	M6×30	6 Nm	10.0 g	1.34.EM63
T-Bolt E	M8×20	18 Nm	12.0 g	1.34.EM82
T-Bolt E	M8×30	18 Nm	14.0 g	1.34.EM83
T-Bolt E	M8×40	18 Nm	18.0 g	1.34.EM84

**Threaded inserts**



**Application**  
For mounting on front end

**Technical data**  
material: steel  
surface: galvanised

**Comments**  
for core hole Ø6

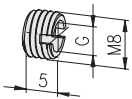

Description	G	Weight	Article-No.
Threaded insert	M8/M4	1.0 g	1.35.10804
Threaded insert	M8/M5	0.9 g	1.35.10805



**Application**  
For mounting on front end

**Technical data**  
material: steel  
surface: galvanised

**Comments**  
for outer chambers PG 50, heavy

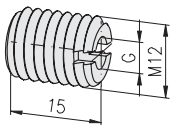

Description	G	Weight	Article-No.
Threaded insert	M12/M4	8.6 g	1.35.11204
Threaded insert	M12/M5	8.0 g	1.35.11205
Threaded insert	M12/M6	7.3 g	1.35.11206
Threaded insert	M12/M8	5.5 g	1.35.11208

**Threaded inserts**



**Application**

For mounting on front end and fastening of any profile with core hole Ø12

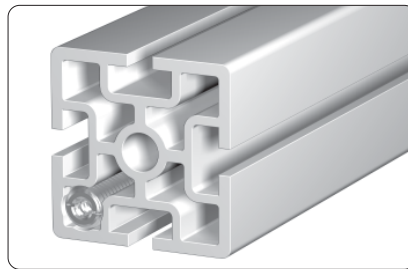

**Application**

For mounting on front end and fastening of profiles PG 45 heavy, PG 50 and PG 60

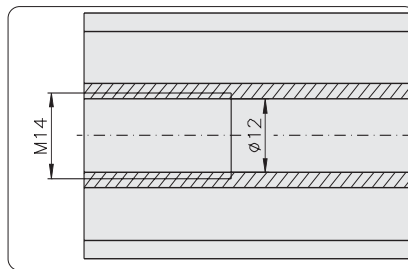

**Assembly preparation for threaded insert M14/Mxx**

- Tap M14 thread in core hole Ø12 mm

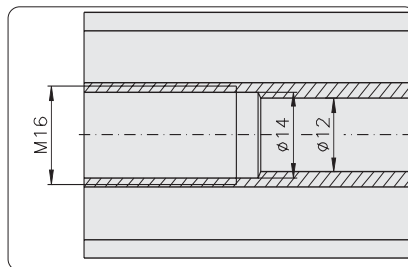

**1) Assembly preparation for threaded insert M16/M12**

- Drill Ø12 mm core hole to 14 mm
- Tap M16 thread in core hole Ø14 mm

**Technical data**

material: steel  
surface: galvanised

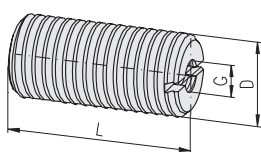

Description	D/G	L	Weight	Article-No.
Threaded insert	M14/M6	15	11 g	1.35.1140615
Threaded insert	M14/M6	30	22 g	1.35.1140630
Threaded insert	M14/M8	15	9 g	1.35.1140815
Threaded insert	M14/M8	30	18 g	1.35.1140830
Threaded insert	M14/M10	15	6 g	1.35.1141015
Threaded insert	M14/M10	30	12 g	1.35.1141030
1) Threaded insert	M16/M12	15	8 g	1.35.1161215
1) Threaded insert	M16/M12	30	16 g	1.35.1161230

**Press-fit threaded inserts**



**Application**

For mounting on front end and fastening of any profile with core hole Ø12

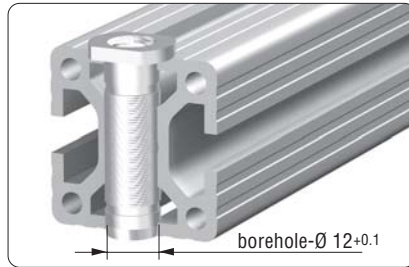

**Application**

For screw connections across the profile for cross section of 20 mm / 30 mm / 40 mm / 50 mm

**Technical data**

material: steel  
surface: galvanised

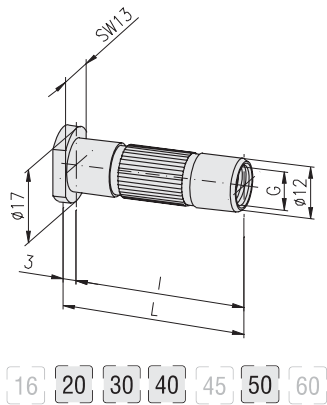

Description	G	L	I	Weight	Article-No.
Press-fit threaded insert	Ø12/M8	22.5	19.5	15 g	1.35.608195
Press-fit threaded insert	Ø12/M8	32.5	29.5	20 g	1.35.608295
Press-fit threaded insert	Ø12/M8	42.5	39.5	26 g	1.35.608395
Press-fit threaded insert	Ø12/M8	52.5	49.5	31 g	1.35.608495
Press-fit threaded insert	Ø12/M10	22.5	19.5	11 g	1.35.610195
Press-fit threaded insert	Ø12/M10	32.5	29.5	15 g	1.35.610295
Press-fit threaded insert	Ø12/M10	42.5	39.5	18 g	1.35.610395
Press-fit threaded insert	Ø12/M10	52.5	49.5	22 g	1.35.610495

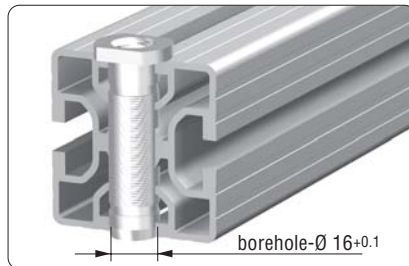

**Application**

For screw connections across the profile for cross section of 30 mm / 40 mm / 50 mm

**Technical data**

material: steel  
surface: galvanised

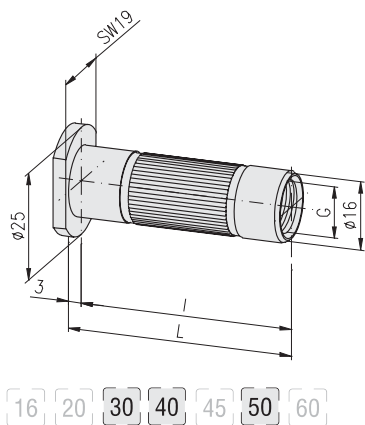

Description	G	L	I	Weight	Article-No.
Press-fit threaded insert	Ø16/M14	32.5	29.5	25 g	1.35.614295
Press-fit threaded insert	Ø16/M14	42.5	39.5	30 g	1.35.614395
Press-fit threaded insert	Ø16/M14	52.5	49.5	35 g	1.35.614495

**Press-fit threaded inserts  
w/o collar**



**Application**

For mounting on front end and fastening of any profile with core hole Ø12

**Technical data**

material: steel  
surface: galvanised

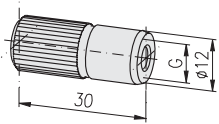

- 16 20 30 40 45 50 60

Description	G	Weight	Article-No.
Press-fit threaded insert, w/o collar	Ø12/M6	19 g	1.35.606300
Press-fit threaded insert, w/o collar	Ø12/M8	17 g	1.35.608300

**Cover profiles**



**Application**

Cover profile with 1.2 mm jutout for the protection of the profile slots

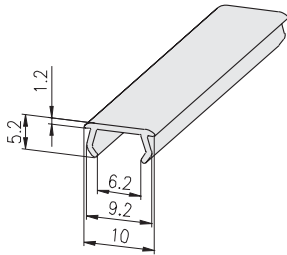

**Technical data**

- bar length: 2.5 m
- material: PVC rigid
- oil and water resistant
- anti-electrostatic
- lead- and cadmium free

Description	similar to RAL	Weight	Article-No.
Cover profile 10, PVC, F/E, grey	7035	85 g/bar	1.41.11.1
Cover profile 10, PVC, F/E, black	9011	85 g/bar	1.41.11.2
Cover profile 10, PVC, F/E, yellow	1023	85 g/bar	1.41.11.1023

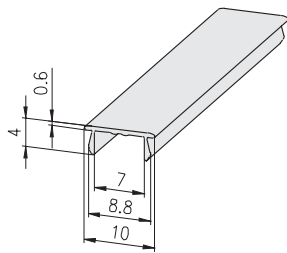

**Technical data**

- bar length: 2.5 m
- material: aluminium
- surface: neutral anodised

Description	Weight	Article-No.
Cover profile 10, Alu, F/E	67.5 g/bar	1.41.121



**Application**

Cover profile for the protection of the profile slots  
Dangerous spots can be marked with yellow cover profiles

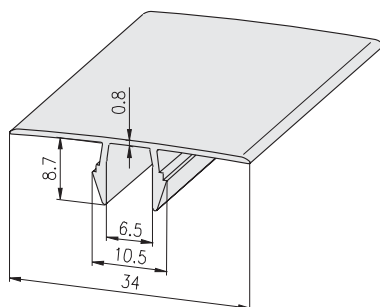

**Technical data**

- bar length: 2.5 m (grey, black)  
3.0 m (yellow)
- material: PVC rigid
- oil and water resistant

Description	similar to RAL	bar	Weight	Article-No.
Cover profile 34, PVC, E, grey	7035	2.5 m	170 g/bar	1.41.15E34.1
Cover profile 34, PVC, E, black	9011	2.5 m	170 g/bar	1.41.15E34.2
Cover profile 34, PVC, E, blue	5017	2.5 m	170 g/bar	1.41.15E34.5017
Cover profile 34, PVC, E, yellow	1003	3.0 m	204 g/bar	1.41.15E34.1003

**Reducing profiles PVC**

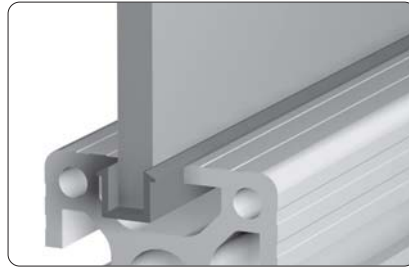

**Application**

To reduce the slot size from 8 mm to 6 mm

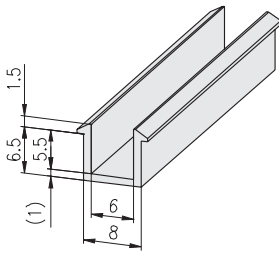

**Technical data**

- bar length: 2.5 m
- material: PVC rigid
- oil and water resistant
- anti-electrostatic
- lead- and cadmium free

Description	Colour	similar to RAL	Weight	Article-No.
Reducing profile PVC, F/E, 8/6	grey	7035	85 g/bar	1.41.21.1
Reducing profile PVC, F/E, 8/6	black	9011	85 g/bar	1.41.21.2



**Combination profiles PVC**

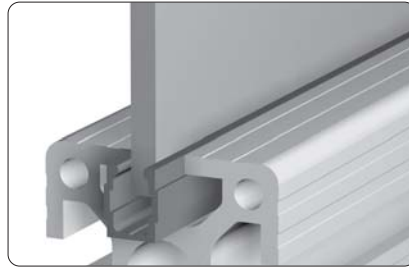

Use as reduction profile



Use as slot-cover profile

**Application**

Combination profiles for use as reduction or cover profiles

**Technical data**

- bar length: 2.5 m
- material: PVC rigid
- oil and water resistant

- Colours:**
- grey
  - black
  - red
  - blue
  - green

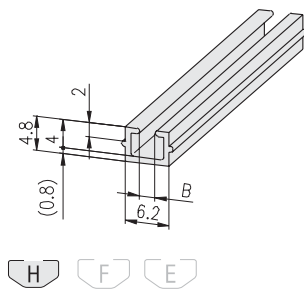

Description	B	Colour	similar to RAL	Weight	Article-No.
Combination profile PVC, H	2	grey	7035	37.5 g/bar	1.41.H02.1
Combination profile PVC, H	2	black	9011	37.5 g/bar	1.41.H02.2
Combination profile PVC, H	2	red	3000	37.5 g/bar	1.41.H02.3000
Combination profile PVC, H	2	blue	5002	37.5 g/bar	1.41.H02.5002
Combination profile PVC, H	2	green	6024	37.5 g/bar	1.41.H02.6024
Combination profile PVC, H	4	grey	7035	35.0 g/bar	1.41.H04.1
Combination profile PVC, H	4	black	9011	35.0 g/bar	1.41.H04.2

## Combination profiles

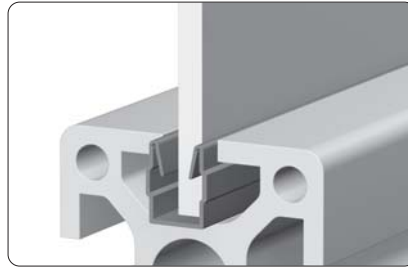

Use as reduction profile

### Application

Combination profiles for use as reduction or cover profiles

### Technical data

bar length: 2.5 m

material: PP

- oil and water resistant

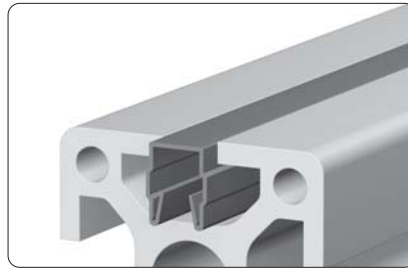

Use as slot-cover profile

**Colours:** grey  
black  
orange  
red  
blue  
green

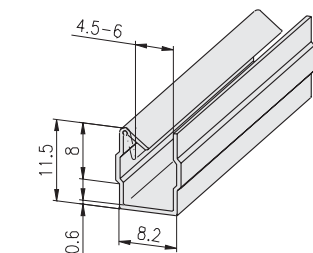
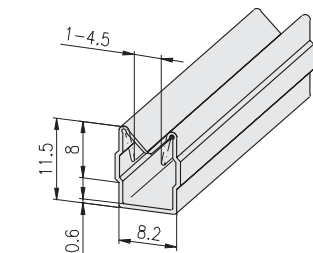
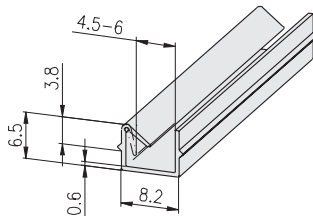
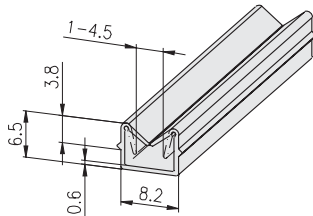

Description	D	Colour	similar to RAL	Weight	Article-No.
Combination profile F	1 - 4.5	grey	7035	31 g/bar	1.41.F14.1
Combination profile F	1 - 4.5	black	9011	31 g/bar	1.41.F14.2

Description	D	Colour	similar to RAL	Weight	Article-No.
Combination profile F	4.5 - 6	grey	7035	28 g/bar	1.41.F46.1
Combination profile F	4.5 - 6	black	9011	28 g/bar	1.41.F46.2
Combination profile F	4.5 - 6	red	3000	28 g/bar	1.41.F46.3000
Combination profile F	4.5 - 6	blue	5002	28 g/bar	1.41.F46.5002
Combination profile F	4.5 - 6	green	6024	28 g/bar	1.41.F46.6024

Description	D	Colour	similar to RAL	Weight	Article-No.
Combination profile E	1 - 4.5	grey	7035	47 g/bar	1.41.E314.1
Combination profile E	1 - 4.5	black	9011	47 g/bar	1.41.E314.2

Description	D	Colour	similar to RAL	Weight	Article-No.
Combination profile E	4.5 - 6	grey	7035	42 g/bar	1.41.E346.1
Combination profile E	4.5 - 6	black	9011	42 g/bar	1.41.E346.2
Combination profile E	4.5 - 6	orange	2004	42 g/bar	1.41.E346.2004
Combination profile E	4.5 - 6	red	3000	42 g/bar	1.41.E346.3000
Combination profile E	4.5 - 6	blue	5002	42 g/bar	1.41.E346.5002
Combination profile E	4.5 - 6	green	6024	42 g/bar	1.41.E346.6024

## Sliding doors construction types

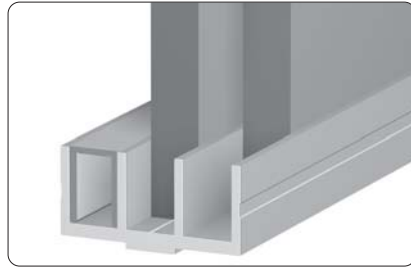

Fixed

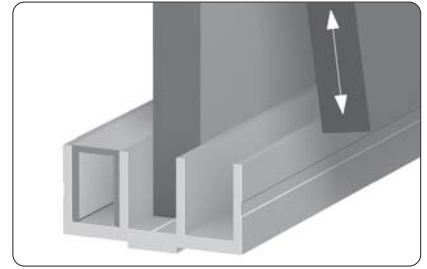

Removable

Profile	Sliding profile 30 mm			Sliding profile 50 mm	
	Fixed	Removable		Fixed	Removable
Type of mounting	Fixed	Removable		Fixed	Removable
Profile above	30×14	30×26	30×26	50×14	50×14
Profile below	30×14	30×14	30×26	50×14	50×14
Panel element 8 mm					
	$H = A - 6$	$H = A - 18$ $H1 = A - 44$	$H = A - 30$ $H1 = A - 56$	$H = A - 9$	$H = A - 19$ $H1 = A - 45$
Panel element 6 mm					
	$H = A - 8$	$H = A - 19$ $H1 = A - 45$	$H = A - 31$ $H1 = A - 57$	$H = A - 9$	$H = A - 19$ $H1 = A - 45$
Panel element 1 - 14 mm					
	$H = A - 6$ $H1 = A - 58$	$H = A - 18$ $H1 = A - 70$	$H = A - 30$ $H1 = A - 82$	$H = A - 17$ $H1 = A - 69$	$H = A - 19$ $H1 = A - 71$

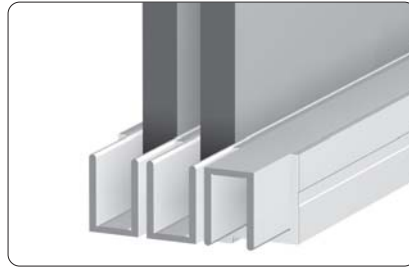
**Combination profiles PVC**

**Application**

Combination profiles for sliding profiles alternatively suitable as:

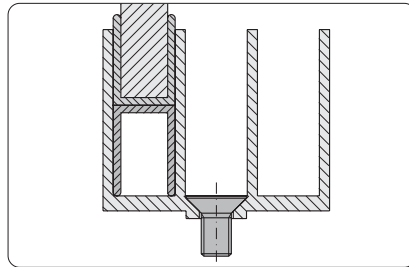
- reducing profile
- cover profile
- Inserted plate (only combination profile 1.41.330)

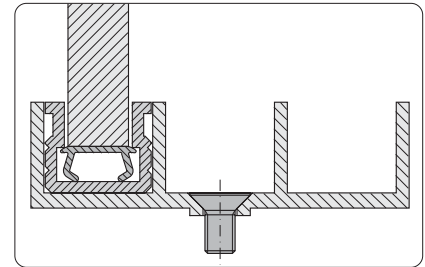

Inserted plate for sliding profile 30×26:  
combination profile 1.41.330



Inserted plate for sliding profile 50×14:  
for sliding profile 1.41.11.1, 1.41.11.2

**Technical data**

bar length: 2.5 m  
 material: PVC rigid  
           oil and water resistant  
 colour: grey

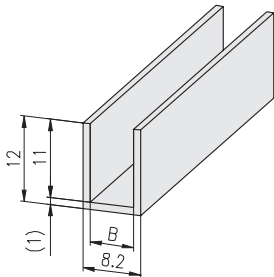

Description	B	Weight	Article-No.
Combination profile PVC for 30×14	6.2	115 g/bar	1.41.330

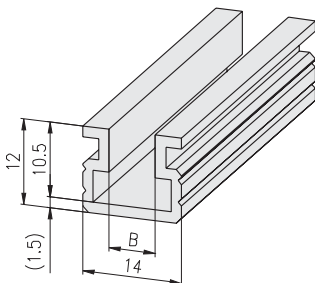

Description	B	Weight	Article-No.
Combination profile PVC for 50×14	6.5	222.5 g/bar	1.41.350
Combination profile PVC for 50×14	9.0	205.0 g/bar	1.41.351

**Guide profile PVC**

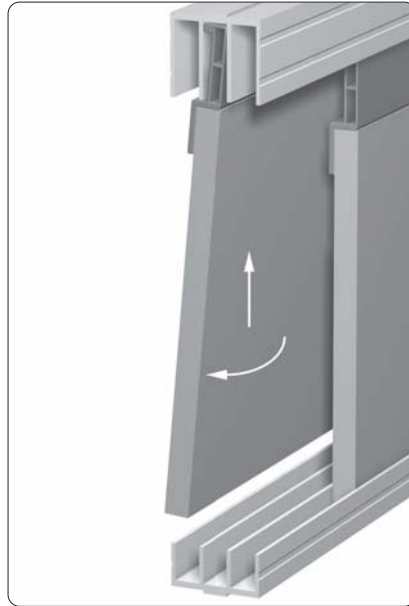

**Application**

- The guide profile is necessary
- For demountable sliding doors
  - For the use of panel elements of each plate thickness from 1 mm to 14 mm

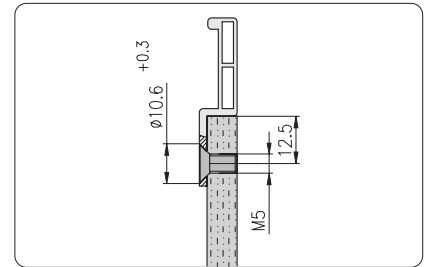

Drill dimensions

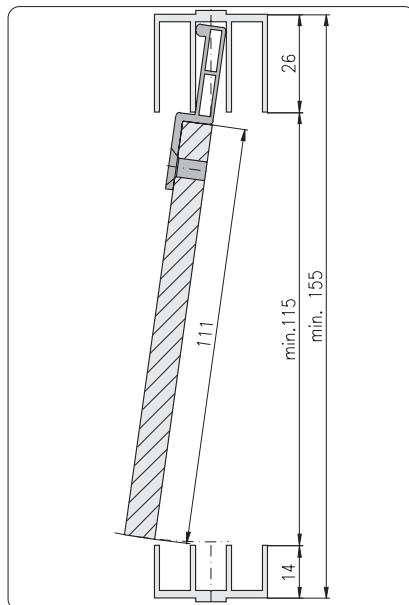

Minimum height for lifting of the panel elements

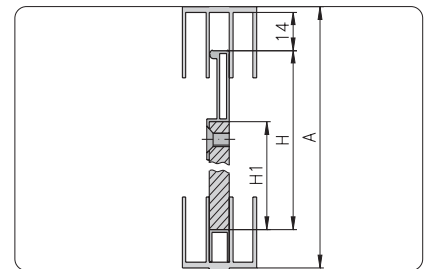

Use in sliding profile 30x26

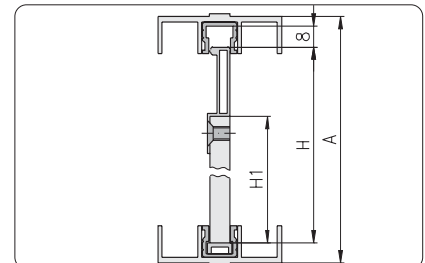

Use in sliding profile 50x14 with combination profile

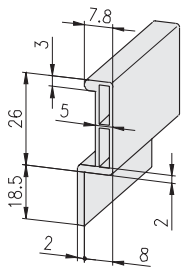

**Technical data**

- bar length: 2.5 m  
 material: PVC rigid  
 oil and water resistant  
 colour: grey

**Description**

Guide profile PVC for sliding profile

**Weight**

375 g/bar

**Article-No.**

1.41.360

**Framing profiles  
one piece**

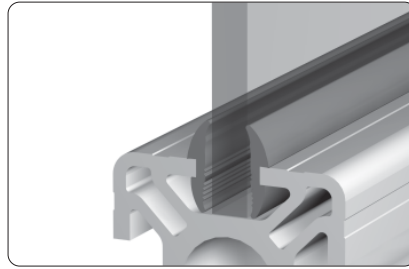

**Application**

The one piece framing profile for mounting panels of different thickness  
The elastic lips provide a good seal

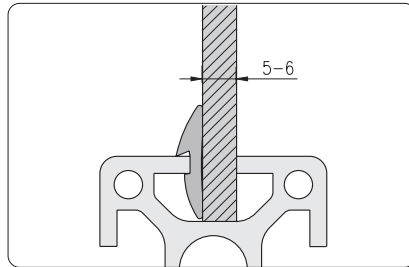

One sided application for profiles with F-slot and panels 5 - 6 mm thick

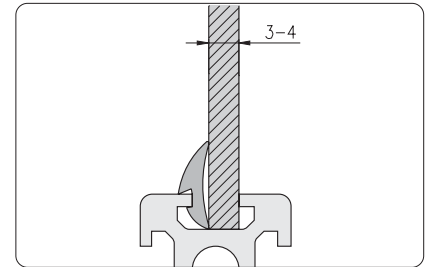

One sided application for profiles with H-slot and panels 3 - 4 mm thick

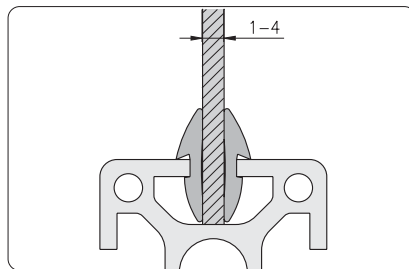

Two sided application for panels 1 - 4 mm thick

**Technical data**

- length of ring: 60 m  
 material: NBR - 60 Shore A
- compatible with acrylic glass
  - oil and water resistant

**Colours**

- grey: similar to RAL 7035  
 black: similar to RAL 9011

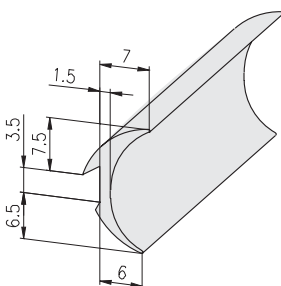
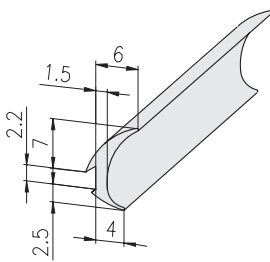

Description	Colour	Weight	Article-No.
Framing profile one piece F	grey ring	2,200 g/ring	1.41.5F0.1.60
Framing profile one piece F	grey cut to length	37 g/m	1.41.5F0.1-A00A00/...
Framing profile one piece F	black ring	2,200 g/ring	1.41.5F0.2.60
Framing profile one piece F	black cut to length	37 g/m	1.41.5F0.2-A00A00/...

/... = length in mm



Description	Colour	Weight	Article-No.
Framing profile one piece E	grey ring	3,120 g/ring	1.41.5E0.1.60
Framing profile one piece E	grey cut to length	52 g/m	1.41.5E0.1-A00A00/...
Framing profile one piece E	black ring	3,120 g/ring	1.41.5E0.2.60
Framing profile one piece E	black cut to length	52 g/m	1.41.5E0.2-A00A00/...

/... = length in mm



**Wedge profiles**



**Application**

Wedge profiles for sealing or fixing of panel elements with a thickness of 4 mm

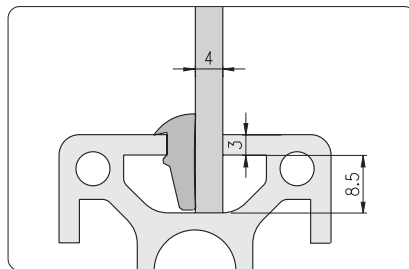
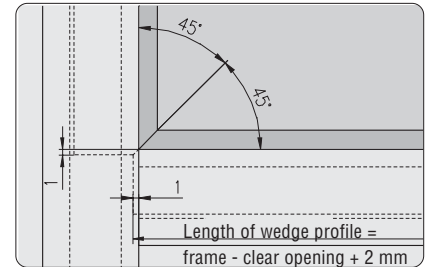
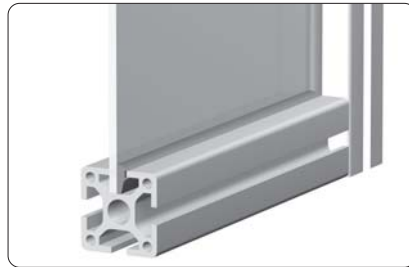

E3-slot

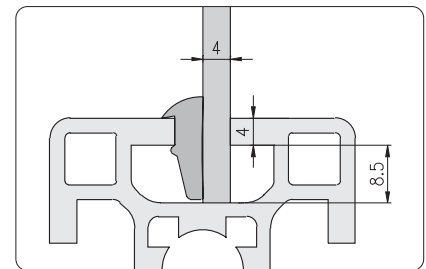

E4-slot

**Technical data**

- length of ring: 100 m
- material: Santoprene
- free of silicon
- compatible with acrylic glass

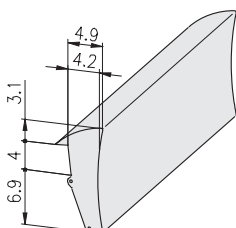
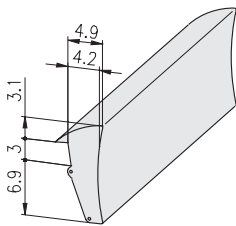

Description	Colour	Weight	Article-No.
Wedge profile E3	grey	ring 5.0 kg/ring	1.41.51E3.1.99
Wedge profile E3	grey	cut to length 50 g/m	1.41.51E3.1-A00A00/... /... = length in mm

Description	Colour	Weight	Article-No.
Wedge profile E4	grey	ring 5.0 kg/ring	1.41.51E4.1.99
Wedge profile E4	grey	cut to length 50 g/m	1.41.51E4.1-A00A00/... /... = length in mm

Sponge rubber round cords

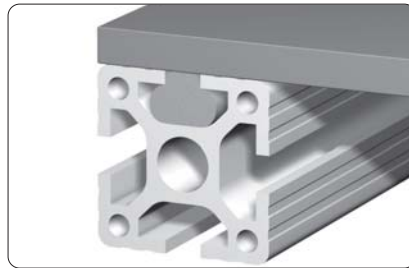

**Application**

Sponge rubber round cords for sealing

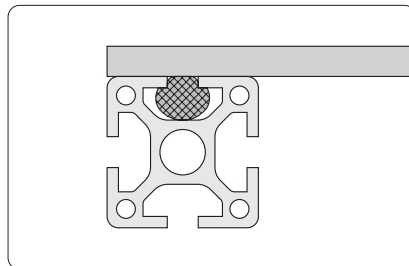

Profile with panel element

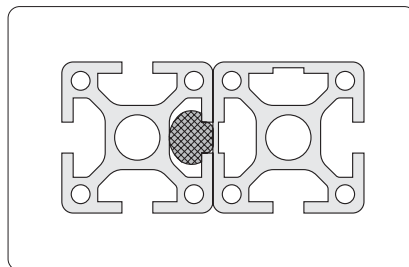

1 profile with slot  
1 profile closed

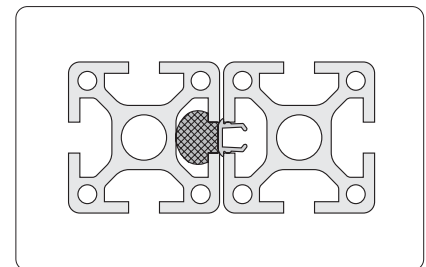

2 profiles with slots  
1 profile with slot-cover profile

Sponge rubber round cord diameter-determination	
Profile slot	Sponge rubber diameter
H-slot	8 mm
F-slot	12 mm
E-slot	18 mm



**Sponge rubber round cords**

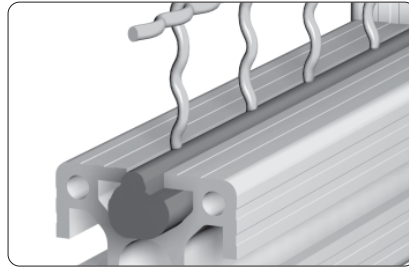

**Application**

For compensation of slot width on in-between sizes of cover panels

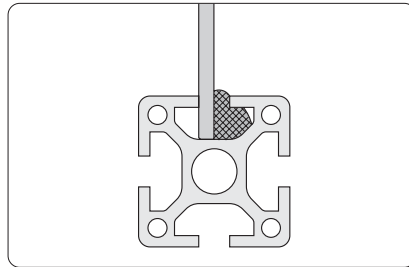

Enclosures with panel materials

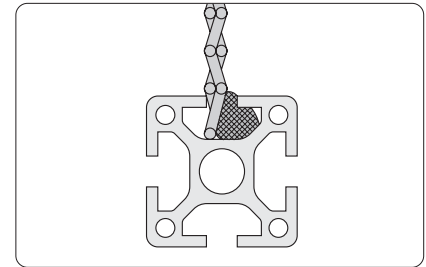

Enclosures with wire screens

Sponge rubber round cord diameter-determination		
Profile slot	Plate thickness	Sponge rubber diameter
H-slot	1 - 3 mm	6 mm
F-slot	1 - 2 mm	10 mm
	3 mm	8 mm
	4 - 5 mm	6 mm
E-slot	1 - 3 mm	10 mm
	3 - 4 mm	2×8 mm
	5 mm	2×6 mm

**Technical data**

length of ring: 100 m  
 material: EPDM  
 colour: grey

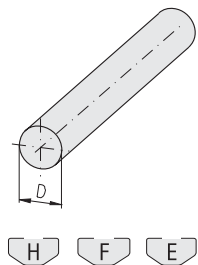

Description	D	Weight	Article-No.
Sponge rubber round cords	Ø6 ring	1.1 kg/ring	1.41.606.99
Sponge rubber round cords	Ø6 cut to length	11 g/m	1.41.606-A00A00/...
Sponge rubber round cords	Ø8 ring	1.9 kg/ring	1.41.608.99
Sponge rubber round cords	Ø8 cut to length	19 g/m	1.41.608-A00A00/...
Sponge rubber round cords	Ø10 ring	3.2 kg/ring	1.41.610.99
Sponge rubber round cords	Ø10 cut to length	32 g/m	1.41.610-A00A00/...
Sponge rubber round cords	Ø12 ring	4.6 kg/ring	1.41.612.99
Sponge rubber round cords	Ø12 cut to length	46 g/m	1.41.612-A00A00/...
Sponge rubber round cords	Ø18 ring	10.0 kg/ring	1.41.618.99
Sponge rubber round cords	Ø18 cut to length	100 g/m	1.41.618-A00A00/...

/... = length in mm

**Sealing profile**

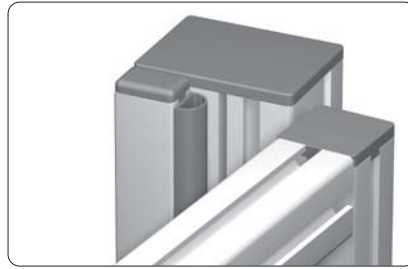

**Application**

For sealing of doors and windows and for door stops

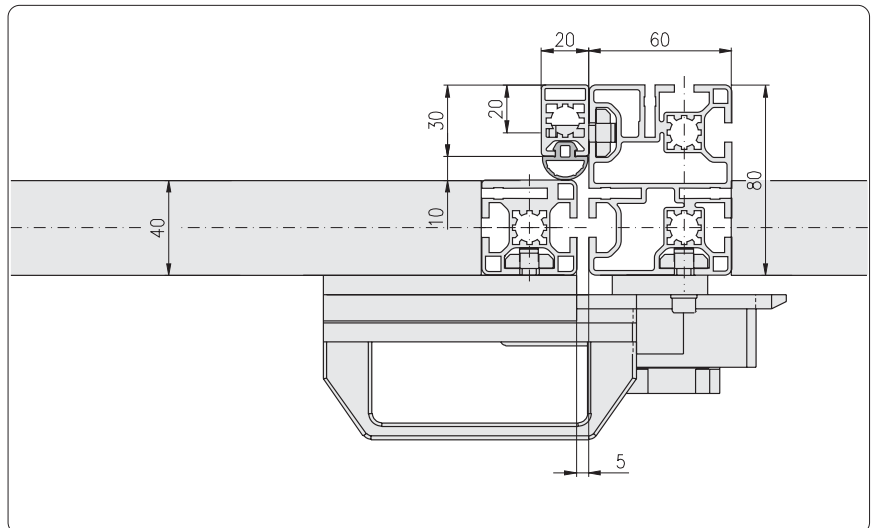

**Technical data**

length of ring: 40 m

material: EPDM, 60° ± 5° Shore A

- free of silicon
- compatible with acrylic glass

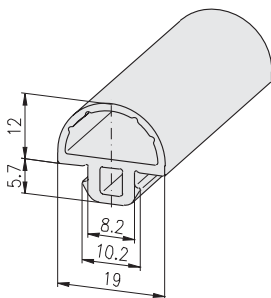

Description	Colour		Weight	Article-No.
Sealing profile F	black	ring	5.12 kg/ring	1.41.6510F.2.40
Sealing profile F	black	cut to length	128 g/m	1.41.6510F.2-A00A00/... /... = length in mm

**Framing profiles**



**Application**

The framing profile allows the installation of panels in closed frames

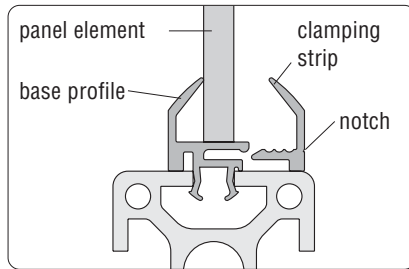

**Assembly**

1. Insert base profile in profile slot
2. Put panel element in position
3. Push clamping strip in position

**Comments**

The clamping strip is badged by a notch as a distinctive mark to the base profile

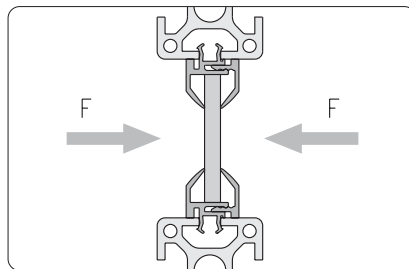

Maximum loading of framing profile:

$$F_{max} = 200 \text{ N/m}$$

For maximum loading of element be aware of the stability of used framing profile

**Technical data**

bar length: 6 m

- material:
- base body: PVC rigid, 98° Shore A
  - lip: PVC soft, TPE 60° ± 5° Shore A, compatible with acrylic glass

temperature range: -20°C to +80°C

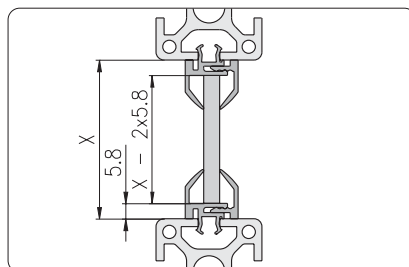



**Comments**

Suitable for panel elements from 1 to 10 mm thickness

**Colours**

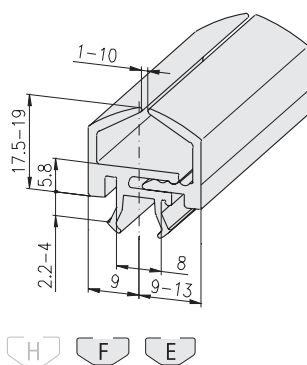
- grey: similar to RAL 7035
- black: similar to RAL 9011



Description	Colour		Weight	Article-No.
Framing profile F/E	grey	bar	1.1 kg/bar	1.41.710.1.60
 Framing profile F/E	grey	cut to length	181 g/m	1.41.710.1-A00A00/...
Framing profile F/E	black	bar	1.1 kg/bar	1.41.710.2.60
 Framing profile F/E	black	cut to length	181 g/m	1.41.710.2-A00A00/...

/... = length in mm

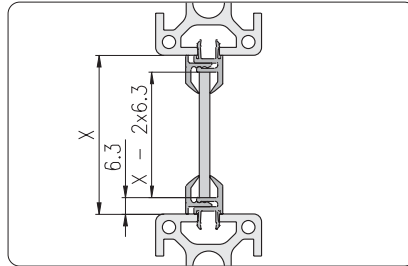
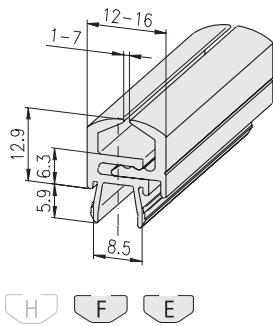



**Comments**

Suitable for panel elements from 1 to 7 mm thickness

**Colours**

grey: similar to RAL 7035  
black: similar to RAL 9011

Description	Colour	Weight	Article-No.
Framing profile F/E, 1-7 mm	grey bar	960 g/bar	1.41.720107.1.60
 Framing profile F/E, 1-7 mm	grey cut to length	160 g/m	1.41.720107.1-A00A00/...
Framing profile F/E, 1-7 mm	black bar	960 g/bar	1.41.720107.2.60
 Framing profile F/E, 1-7 mm	black cut to length	160 g/m	1.41.720107.2-A00A00/...

/... = length in mm

**Rubber cover-profiles**



**Application**

Rubber cover-profiles for profile protection  
Suitable for:

- door stop
- slide prevention on steps
- protection against damage
- handrails
- pads

**Technical data**

length of ring: 20 m  
material: NBR, hardness 80 Shore A  
oil and water resistant  
colour: black

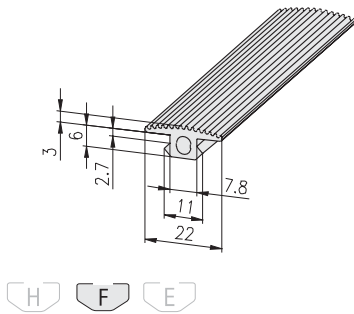

**Description**

Description	Weight	Article-No.
Rubber cover-profile F, black ring	2.4 kg/ring	1.41.8F30.20
Rubber cover-profile F, black cut to length	120 g/m	1.41.8F30-A00A00/... /... = length in mm

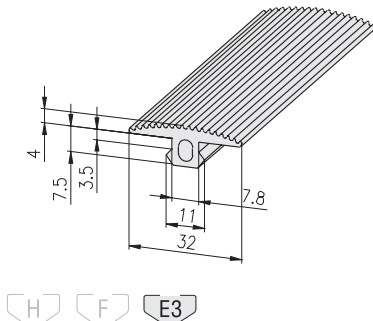

**Description**

Description	Weight	Article-No.
Rubber cover-profile E3, black ring	4.4 kg/ring	1.41.8E40.20
Rubber cover-profile E3, black cut to length	220 g/m	1.41.8E40-A00A00/... /... = length in mm

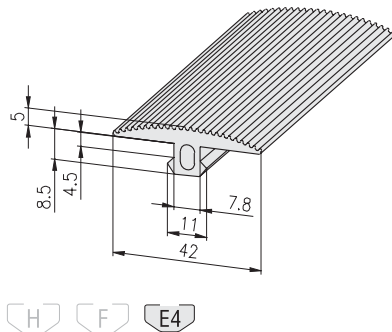

**Description**

Description	Weight	Article-No.
Rubber cover-profile E4, black ring	6.4 kg/ring	1.41.8E50.20
Rubber cover-profile E4, black cut to length	320 g/m	1.41.8E50-A00A00/... /... = length in mm

## Cover caps

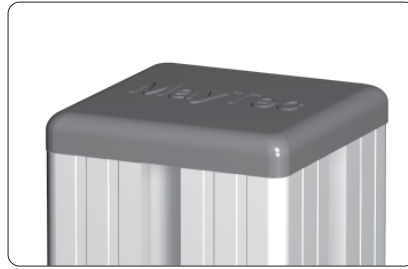

### Application

Cover caps prevent dirt from entering and avoid lacerations.

### Technical data

material: PA-GF  
temperature range: -20°C to +85°C

### Comments

Before mounting debur core hole

### Rectangle

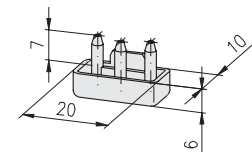
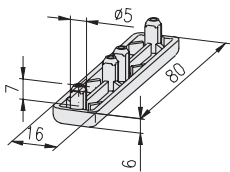
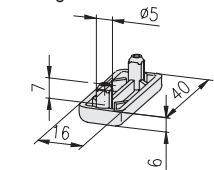

### for profiles without core hole

Description	Colour	Weight	Article-No.
Cover cap 16×40, E only for E-Slot	black	3.9 g	1.42.09016040.2

Description	Colour	Weight	Article-No.
Cover cap 16×80, E	grey	7.1 g	1.42.09016080.1
Cover cap 16×80, E only for E-Slot	black	7.1 g	1.42.09016080.2

Description	Colour	Weight	Article-No.
Cover cap 20×10	black	2 g	1.42.20201.2

### Soft

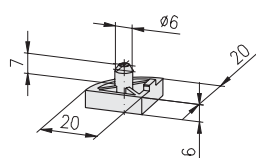

### for profiles with core hole-Ø6

Description	Colour	Weight	Article-No.
Cover cap 20×20	grey	3 g	1.42.10200.1
Cover cap 20×20	black	3 g	1.42.10200.2

### Square

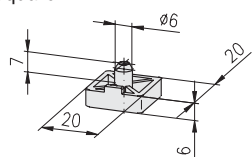

Description	Colour	Weight	Article-No.
Cover cap 20×20	grey	3 g	1.42.10202.1
Cover cap 20×20	black	3 g	1.42.10202.2

### Rectangle

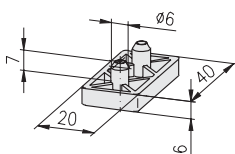

Description	Colour	Weight	Article-No.
Cover cap 20×40	grey	6 g	1.42.10204.1
Cover cap 20×40	black	6 g	1.42.10204.2

### Square

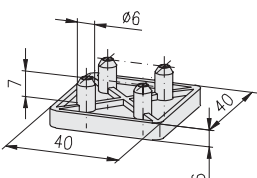

Description	Colour	Weight	Article-No.
Cover cap 40×40	black	6 g	1.42.10404.2

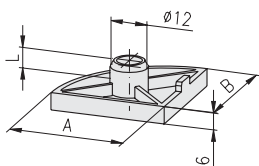
**for profiles with core hole-Ø12**
**Soft**

Description	A×B	L	Colour	Weight	Article-No.
Cover cap	30×30	7	grey	5 g	1.42.20300.1
Cover cap	30×30	7	black	5 g	1.42.20300.2
Cover cap	40×40	7	grey	8 g	1.42.20400.1
Cover cap	40×40	7	black	8 g	1.42.20400.2
Cover cap	50×50	7	grey	12 g	1.42.20500.1
Cover cap	50×50	7	black	12 g	1.42.20500.2

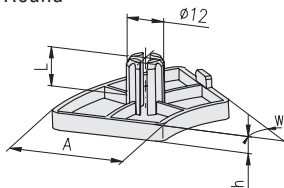
**Round**

**note "h" !**

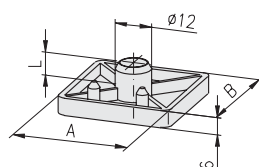
Description	A	W	h	L	Colour	Weight	Article-No.
Cover cap	40, round 30°	4	14		black	6 g	1.42.2040R30.2
Cover cap	40, round 45°	6	14		black	8 g	1.42.2040R45.2
Cover cap	40, round 60°	6	14		black	12 g	1.42.2040R60.2
Cover cap	40, round 90°	6	14		black	16 g	1.42.2040R90.2

**Square**

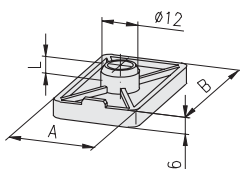
Description	A×B	L	Colour	Weight	Article-No.
Cover cap	30×30	14	grey	6 g	1.42.20303.1
Cover cap	30×30	14	black	6 g	1.42.20303.2
Cover cap	40×40	7	grey	10 g	1.42.20404.1
Cover cap	40×40	7	black	10 g	1.42.20404.2
Cover cap	45×45	14	black	12 g	1.42.2045045.2
Cover cap	50×50	7	grey	15 g	1.42.20505.1
Cover cap	50×50	7	black	15 g	1.42.20505.2
Cover cap	60×60	14	black	18 g	1.42.2060060.2

**Rectangle**

Description	A×B	L	Colour	Weight	Article-No.
Cover cap	20×30	7	black	4 g	1.42.20203.2
Cover cap	30×50	7	grey	8 g	1.42.20305.1
Cover cap	30×50	7	black	8 g	1.42.20305.2
Cover cap	45×60	14	black	12.1 g	1.42.2045060.2

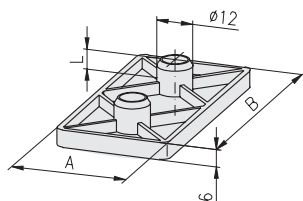

Description	A×B	L	Colour	Weight	Article-No.
Cover cap	30×60	7	grey	8 g	1.42.20306.1
Cover cap	30×60	7	black	8 g	1.42.20306.2
Cover cap	30×100	7	black	20 g	1.42.20310.2
1) Cover cap	30×150	7	black	27 g	1.42.20315.2
Cover cap	40×80	7	grey	18 g	1.42.20408.1
Cover cap	40×80	7	black	18 g	1.42.20408.2
Cover cap	45×90	14	black	20.5 g	1.42.2045090.2
Cover cap	50×100	7	grey	26 g	1.42.20510.1
Cover cap	50×100	7	black	26 g	1.42.20510.2
Cover cap	50×150	7	black	40 g	1.42.20515.2
Cover cap	60×90	14	black	25.9 g	1.42.2060090.2

1) only for E-Slot

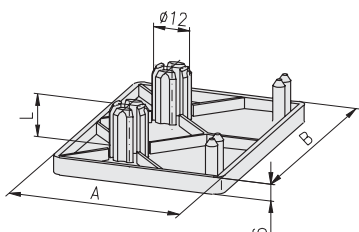

Description	A×B	L	Colour	Weight	Article-No.
Cover cap	60×80	14	black	21.4 g	1.42.2060080.2

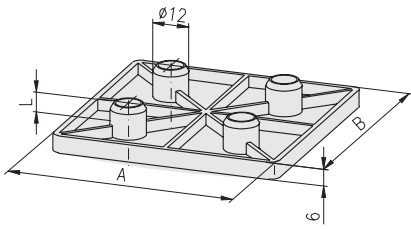
**Square**

Description	AxB	L	Colour	Weight	Article-No.
Cover cap	80x80	7	black	34 g	1.42.20808.2
Cover cap	90x90	14	black	42 g	1.42.2090090.2
Cover cap	100x100	7	black	52 g	1.42.21010.2

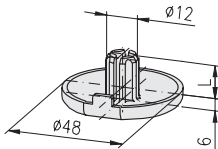
**Ø48 for hand rail profile**

**C Technical data**  
 material: PA-GF

Description	L	Colour	Weight	Article-No.
Cover cap Ø48 for hand rail profile	14	grey	1.8 g	1.42.2048R00.1
Cover cap Ø48 for hand rail profile	14	black	1.8 g	1.42.2048R00.2



**Cover plugs**



Cover plug in combination with cover profile

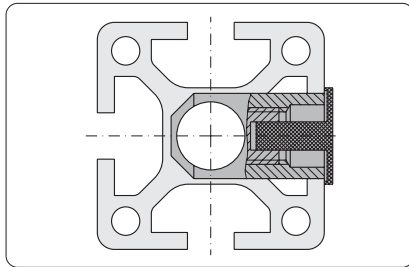

**Application**

The cover plug allows the closing of the connector cross bushing bore

**Technical data**

material: PE

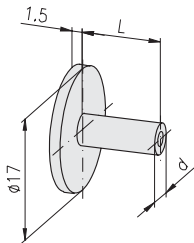

Description	Colour	L	d	Weight	Article-No.
Cover plug 20	grey	3.5	Ø4.3	2 g	1.42.502.1
Cover plug 20	black	3.5	Ø4.3	2 g	1.42.502.2
Cover plug 30	grey	6.0	Ø5.3	3 g	1.42.503.1
Cover plug 30	black	6.0	Ø5.3	3 g	1.42.503.2
Cover plug 40	grey	11.0	Ø5.3	4 g	1.42.504.1
Cover plug 40	black	11.0	Ø5.3	4 g	1.42.504.2
Cover plug 50	grey	16.0	Ø5.3	5 g	1.42.505.1
Cover plug 50	black	16.0	Ø5.3	5 g	1.42.505.2

**Cover plugs domed**

C

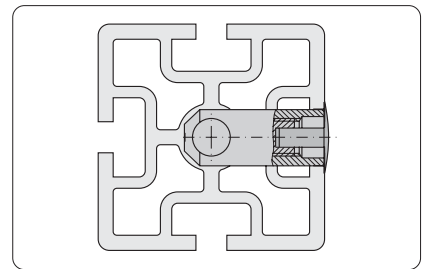

**Application**

The cover plug allows the closing of the connector cross bushing bore

**Technical data**

material: PE

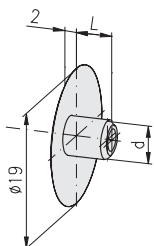

Description	Colour	L	d	Weight	Article-No.
Cover plug 20 domed	grey	3.5	Ø4.3	0.2 g	1.42.5120.1
Cover plug 20 domed	black	3.5	Ø4.3	0.2 g	1.42.5120.2
Cover plug 30 domed	grey	6.0	Ø5.3	0.3 g	1.42.5130.1
Cover plug 30 domed	black	6.0	Ø5.3	0.3 g	1.42.5130.2
Cover plug 40 domed	grey	11.0	Ø5.3	0.4 g	1.42.5140.1
Cover plug 40 domed	black	11.0	Ø5.3	0.4 g	1.42.5140.2
Cover plug 45 domed	grey	12.5	Ø5.3	0.4 g	1.42.5145.1
Cover plug 45 domed	black	12.5	Ø5.3	0.4 g	1.42.5145.2
Cover plug 50 domed	grey	15.0	Ø5.3	0.5 g	1.42.5150.1
Cover plug 50 domed	black	15.0	Ø5.3	0.5 g	1.42.5150.2
Cover plug 60 domed	grey	20.0	Ø5.3	0.7 g	1.42.5160.1
Cover plug 60 domed	black	20.0	Ø5.3	0.7 g	1.42.5160.2

**Cover caps for tubes**

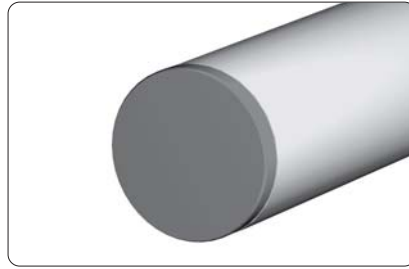

**Application**

The cover cap allows the closing of the aluminium tube (inner tube  $\varnothing = d$ )

**Technical data**

material: PE

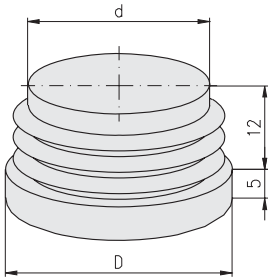

Description	D	Colour	d	Weight	Article-No.
Tube cover cap	Ø20	grey	Ø16	1.8 g	1.42.6020.1
Tube cover cap	Ø20	black	Ø16	1.8 g	1.42.6020.2
Tube cover cap	Ø30	grey	Ø24	3.4 g	1.42.6030.1
Tube cover cap	Ø30	black	Ø24	3.4 g	1.42.6030.2
Tube cover cap	Ø40	grey	Ø32	5.3 g	1.42.6040.1
Tube cover cap	Ø40	black	Ø32	5.3 g	1.42.6040.2

**Cover caps for screw bores**

C

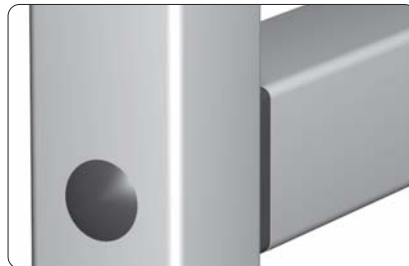

**Application**

The cover plug allows the closing of the screw bore

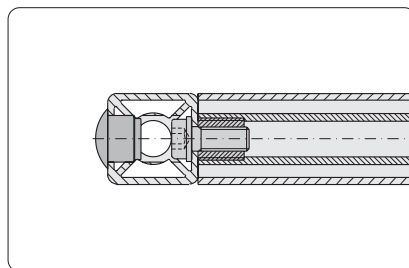

Profile 30

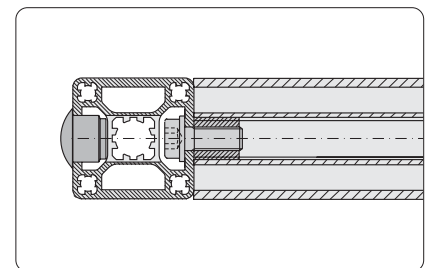

Profile 40

**Technical data**

material: PE

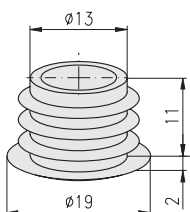

Description	Colour	Weight	Article-No.
Cover plug	Ø15 grey	1.3 g	1.42.6114.1
Cover plug	Ø15 black	1.3 g	1.42.6114.2

**Radius covers**

C



**Application**

For covering the exterior profile radius

**Technical data**

material: PA-GF

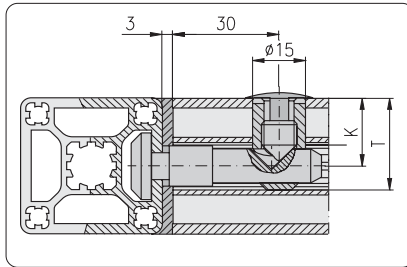

Drill dimensions by use of radius covers (dimensions K, T → connector-cross bushings 1.2B)

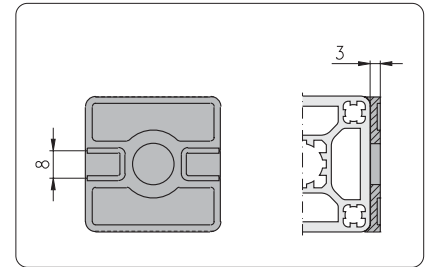

For mounting of panels the slots can be broken out

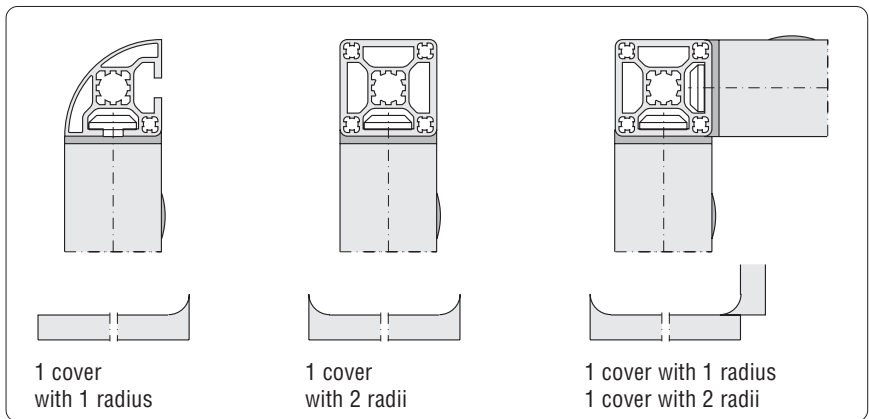

Mounting-Variations

**Square**

with one radius

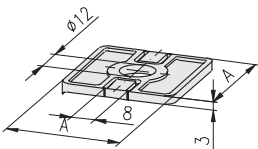

Description	A	Colour	Weight	Article-No.
Radius cover 1R	30	grey	3.1 g	1.43.10030030.1
Radius cover 1R	30	black	3.1 g	1.43.10030030.2
Radius cover 1R	40	grey	6.1 g	1.43.10040040.1
Radius cover 1R	40	black	6.1 g	1.43.10040040.2
Radius cover 1R	45	grey	5.4 g	1.43.10045045.1
Radius cover 1R	45	black	5.4 g	1.43.10045045.2

**Rectangle**

with one radius

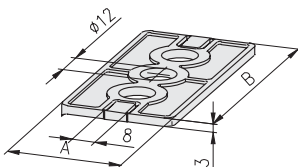

Description	A	B	Colour	Weight	Article-No.
Radius cover 1R	30	60	grey	5.8 g	1.43.10030060.1
Radius cover 1R	30	60	black	5.8 g	1.43.10030060.2
Radius cover 1R	40	80	grey	11.8 g	1.43.10040080.1
Radius cover 1R	40	80	black	11.8 g	1.43.10040080.2
Radius cover 1R	45	90	grey	10.7 g	1.43.10045090.1
Radius cover 1R	45	90	black	10.7 g	1.43.10045090.2

**Rectangle 90°**

with one radius

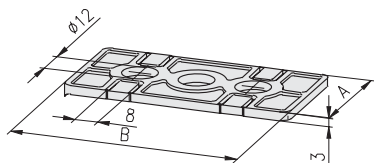

Description	A	B	Colour	Weight	Article-No.
Radius cover 1R	30	60	grey	5.8 g	1.43.11030060.1
Radius cover 1R	30	60	black	5.8 g	1.43.11030060.2
Radius cover 1R	40	80	grey	11.8 g	1.43.11040080.1
Radius cover 1R	40	80	black	11.8 g	1.43.11040080.2
Radius cover 1R	45	90	grey	10.8 g	1.43.11045090.1
Radius cover 1R	45	90	black	10.8 g	1.43.11045090.2

**Square**

with one radius

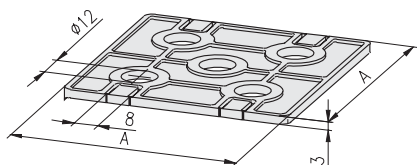

Description	A	Colour	Weight	Article-No.
Radius cover 1R	60	grey	12.0 g	1.43.10060060.1
Radius cover 1R	60	black	12.0 g	1.43.10060060.2
Radius cover 1R	80	grey	24.0 g	1.43.10080080.1
Radius cover 1R	80	black	24.0 g	1.43.10080080.2

**Square**

with two radii

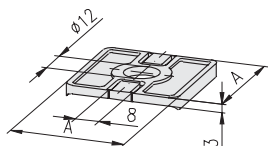

Description	A	Colour	Weight	Article-No.
Radius cover 2R	30	grey	3.2 g	1.43.20030030.1
Radius cover 2R	30	black	3.2 g	1.43.20030030.2
Radius cover 2R	40	grey	6.3 g	1.43.20040040.1
Radius cover 2R	40	black	6.3 g	1.43.20040040.2
Radius cover 2R	45	grey	5.6 g	1.43.20045045.1
Radius cover 2R	45	black	5.6 g	1.43.20045045.2

**Rectangle**

with two radii

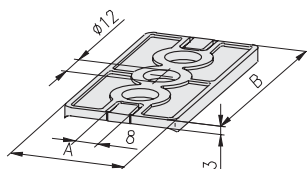

Description	A	B	Colour	Weight	Article-No.
Radius cover 2R	30	60	grey	6.0 g	1.43.20030060.1
Radius cover 2R	30	60	black	6.0 g	1.43.20030060.2
Radius cover 2R	40	80	grey	12.0 g	1.43.20040080.1
Radius cover 2R	40	80	black	12.0 g	1.43.20040080.2
Radius cover 2R	45	90	grey	10.9 g	1.43.20045090.1
Radius cover 2R	45	90	black	10.9 g	1.43.20045090.2

**Rectangle 90°**

with two radii

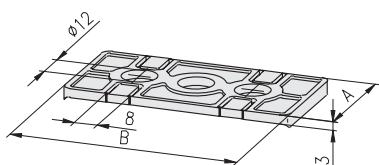

Description	A	B	Colour	Weight	Article-No.
Radius cover 2R	30	60	grey	6.0 g	1.43.21030060.1
Radius cover 2R	30	60	black	6.0 g	1.43.21030060.2
Radius cover 2R	40	80	grey	12.0 g	1.43.21040080.1
Radius cover 2R	40	80	black	12.0 g	1.43.21040080.2
Radius cover 2R	45	90	grey	11.0 g	1.43.21045090.1
Radius cover 2R	45	90	black	11.0 g	1.43.21045090.2

**Square**

with two radii

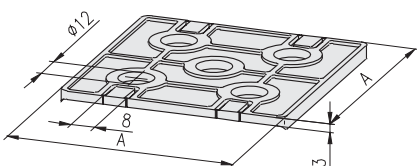

Description	A	Colour	Weight	Article-No.
Radius cover 2R	60	grey	12.0 g	1.43.20060060.1
Radius cover 2R	60	black	12.0 g	1.43.20060060.2
Radius cover 2R	80	grey	24.0 g	1.43.20080080.1
Radius cover 2R	80	black	24.0 g	1.43.20080080.2

**Radius compensations**

C

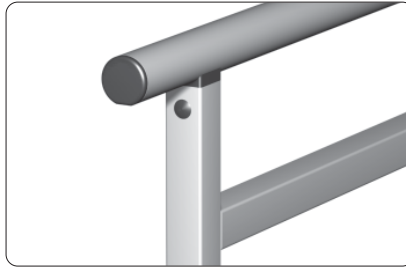

**Application**

Radius compensation for hand rails  
 ↳ Profile applications 1.1E.03

**Comments**

Angled joints at any required angle  
 Not suitable for the use with tilted hand rails

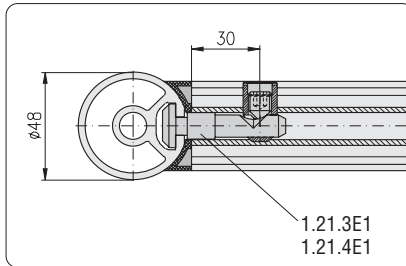
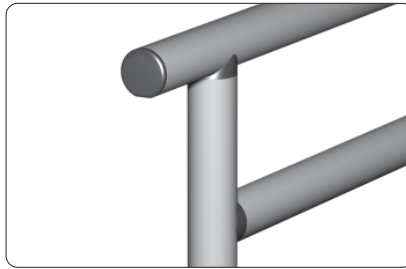

Working dimensions for hand rail straight with radius compensation

**Technical data**

material: PA-GF

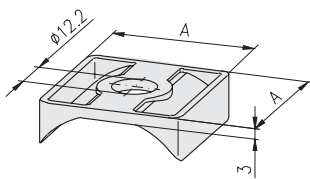

- 16
- 20
- 30
- 40
- 45
- 50
- 60

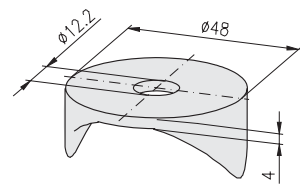

Description	AxA	Colour	Weight	Article-No.
Radius compensations	30x30	grey	4.0 g	1.43.71030030.1
Radius compensations	30x30	black	4.0 g	1.43.71030030.2
Radius compensations	40x40	grey	7.0 g	1.43.71040040.1
Radius compensations	40x40	black	7.0 g	1.43.71040040.2

Description	Colour	Weight	Article-No.
Radius compensations Ø48	grey	4.0 g	1.43.71048000.1
Radius compensations Ø48	black	4.0 g	1.43.71048000.2

**Levelling feet**

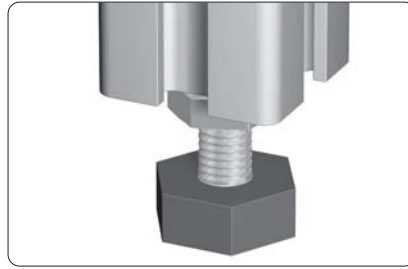

**Assembly**

Fastening in core hole  $\varnothing 6$  mm with thread M8

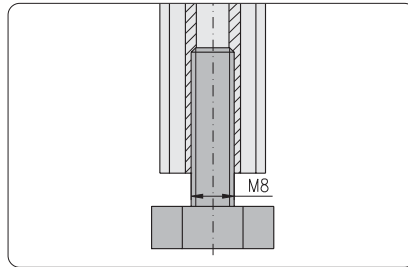

Fastening in core hole  $\varnothing 6$  mm with thread M8

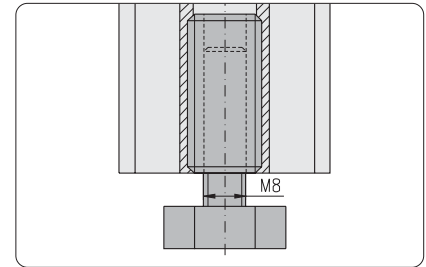

Fastening in core hole  $\varnothing 12$  with threaded insert M14/M8

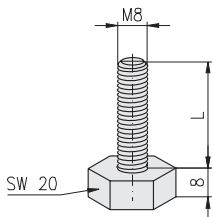

**Technical data**

- material:
- plate: PE-HD
  - screw: steel, galvanised
- max. static load: 2,500 N

**Description**

Floor levelling screw, SW20, M8x30

**Weight**

20 g

**Article-No.**

1.44.002003

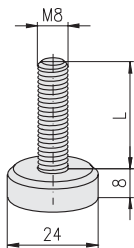

**Technical data**

- material:
- plate: PE-HD
  - screw: steel, galvanised
- max. static load: 2,500 N

**Description**

Floor levelling screw,  $\varnothing 24$ , M8x30

**Weight**

22 g

**Article-No.**

1.44.002403

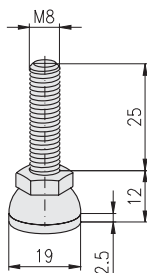

**Technical data**

- material:
- foot plate: PA, black
  - threaded bolt: steel, galvanised
- max. static load: 500 N  
with anti-slip-disc

**Description**

Levelling foot, PA, 20 M8x25

**Weight**

14 g

**Article-No.**

1.44.003020

**Hand adjustable feet**

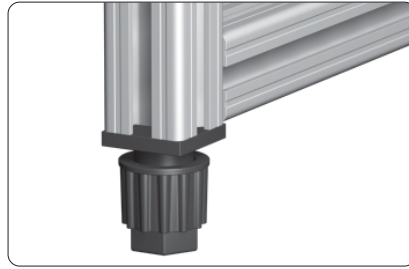

**Application**

For manual levelling of benches, tables and light bases.

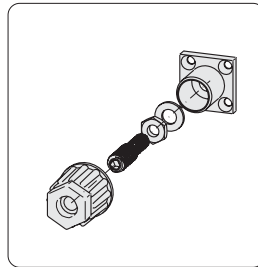

Height adjustable alternative by hand or with tool

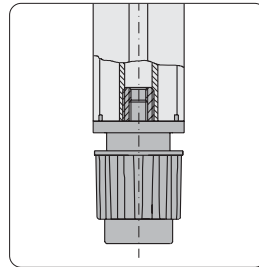

Fastening in core hole

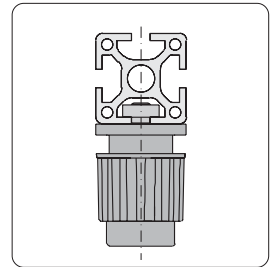

Fastening in slot

**Technical data**

material:

- capsule: PA, black
  - spindle, nut and washer: steel galvanised
- max. static load: 1,500 N

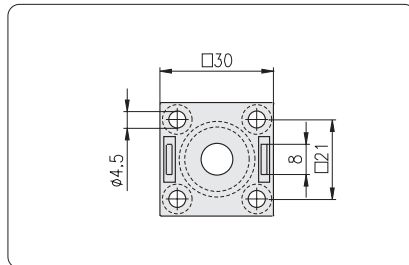
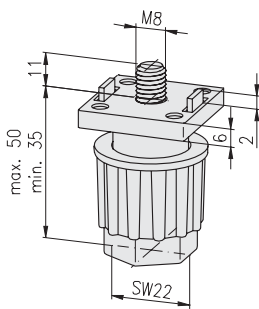

**Description**

Hand adjustable foot 30

**Weight**

40 g

**Article-No.**

1.44.203008

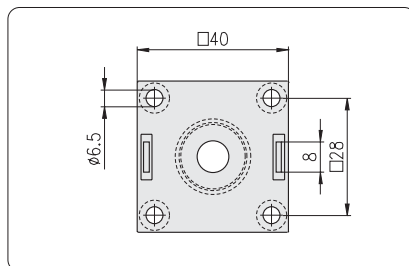
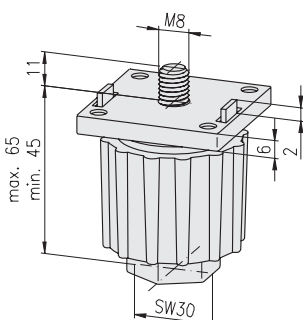

**Description**

Hand adjustable foot 40

**Weight**

78 g

**Article-No.**

1.44.204008

**Levelling feet**



**Assembly**

Fastening in core hole with threaded insert M14/M10

For profiles with core hole-Ø 12 mm

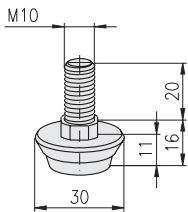

**Technical data**

material:

- foot plate: PA, black
- cap: steel, galvanised
- screw thread: steel, galvanised
- max. static load: 1,500 N

**Description**

Levelling furniture foot, Ø30, M10×18

**Weight**

**Article-No.**

24 g

1.44.303002

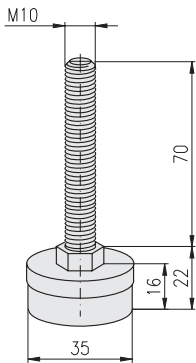

**Technical data**

material:

- foot plate: PA, black
- cap: steel, galvanised
- screw thread: steel, galvanised
- max. static load: 1,500 N

**Description**

Levelling foot, Ø35, M10×70

**Weight**

**Article-No.**

70 g

1.44.303507

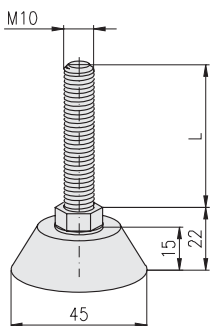

**Technical data**

material:

- foot plate: PA, black
- screw thread: steel, galvanised
- max. static load: 1,500 N

**Description**

**L**

Levelling foot, Ø45, M10×50

Levelling foot, Ø45, M10×70

**Weight**

**Article-No.**

60 g

1.44.304505

69 g

1.44.304507



**Adjustable tilt-feet**



**Application**

Adjustable tilt-feet for gradual height adjustment of sub-assemblies such as:

- tables
- bases
- shelves
- stands



Fastening in core hole thread M14

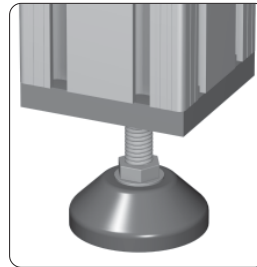

Fastening with base plate, for profiles without centric core hole

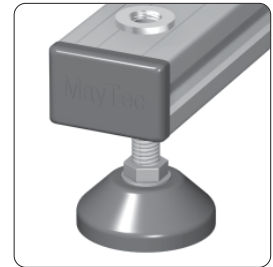

Fastening by press-fit threaded insert across the profile

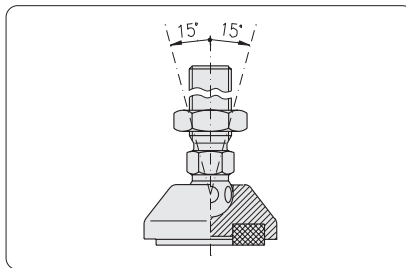

Levelling via ball and ball socket  $\pm 15^\circ$

**Comments**

Infinitely variable adjustable tilt-feet for use either with:

- anti-slip disc
- cushion element

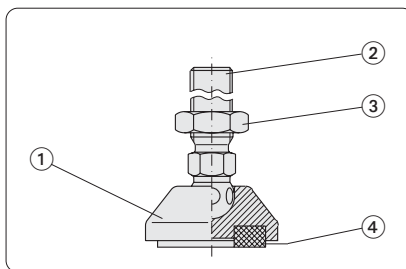

Adjustable tilt-feet - Single parts						
Pos.	Description	Material				
		PA	GD-Zn	Steel	Stainl. steel 1.4305	NBR
	Adjustable tilt-foot-					
①	plate	•	•		•	
②	spindle			•	•	
③	nut			•	•	
④	anti-slip disc cushion element					• •

## Adjustable tilt-foot plates without mounting holes

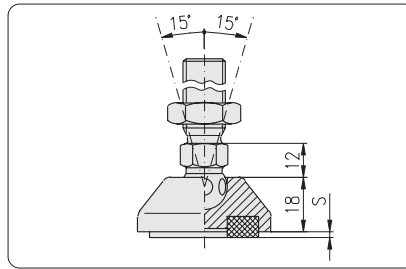
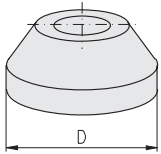

Design without mounting holes

### Technical data

material:

PA: PA-GF, black

GD-Zn: GD-Zn, black powder-coated

stainless: stainless steel 1.4305

F = static load max. in kN

S = height of:

- anti-slip disc (S = 2 mm)
- cushion element (S = 10 mm)

### PA

Description	D	F	Weight	Article-No.
Adjustable tilt-foot plate PA, 30	Ø29	5 kN	8 g	1.44.411030
Adjustable tilt-foot plate PA, 40	Ø39	9 kN	13 g	1.44.411040
Adjustable tilt-foot plate PA, 45	Ø44	9 kN	15 g	1.44.411045
Adjustable tilt-foot plate PA, 50	Ø49	9 kN	16 g	1.44.411050
Adjustable tilt-foot plate PA, 60	Ø59	9 kN	22 g	1.44.411060

### GD-Zn

Adjustable tilt-foot plate GD-Zn, 30	Ø29	20 kN	48 g	1.44.431030
Adjustable tilt-foot plate GD-Zn, 40	Ø39	30 kN	70 g	1.44.431040
Adjustable tilt-foot plate GD-Zn, 45	Ø44	30 kN	90 g	1.44.431045
Adjustable tilt-foot plate GD-Zn, 50	Ø49	30 kN	126 g	1.44.431050
Adjustable tilt-foot plate GD-Zn, 60	Ø59	30 kN	160 g	1.44.431060
Adjustable tilt-foot plate GD-Zn, 80	Ø79	30 kN	260 g	1.44.431080
Adjustable tilt-foot plate GD-Zn, 100	Ø99	35 kN	400 g	1.44.431100
Adjustable tilt-foot plate GD-Zn, 120	Ø119	35 kN	584 g	1.44.431120

### Stainless steel

**C** **R**

Adjustable tilt-foot plate, 30	Ø29	20 kN	62 g	1.44.431030V
Adjustable tilt-foot plate, 40	Ø39	30 kN	99 g	1.44.431040V
Adjustable tilt-foot plate, 45	Ø44	30 kN	123 g	1.44.431045V
Adjustable tilt-foot plate, 50	Ø49	35 kN	158 g	1.44.431050V
Adjustable tilt-foot plate, 60	Ø59	35 kN	218 g	1.44.431060V
Adjustable tilt-foot plate, 80	Ø79	35 kN	380 g	1.44.431080V
Adjustable tilt-foot plate, 100	Ø99	40 kN	605 g	1.44.431100V
Adjustable tilt-foot plate, 120	Ø119	40 kN	844 g	1.44.431120V

**Adjustable tilt-foot plates with mounting holes**

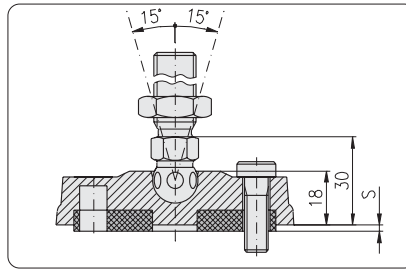
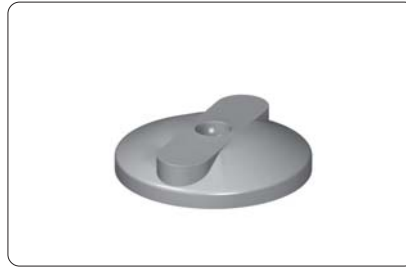
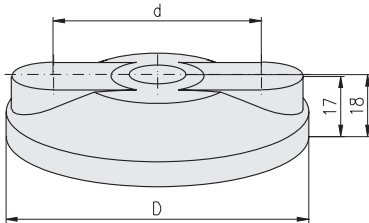

Design with mounting holes

**Technical data**

material:  
PA: PA-GF, black  
F = static load max. in kN

**Comments**

The holes for fastening screws are closed on the upper side and can be bored open if required.

- S = height of:
- anti-slip disc (S = 2 mm)
  - cushion element (S = 10 mm)

**PA**

Description	D	d	F	Weight	Article-No.
Adjustable tilt-foot plate PA, 80	Ø79	Ø54	9 kN	46 g	1.44.411080
Adjustable tilt-foot plate PA, 100	Ø99	Ø74	9 kN	86 g	1.44.411100
Adjustable tilt-foot plate PA, 120	Ø119	Ø94	9 kN	104 g	1.44.411120

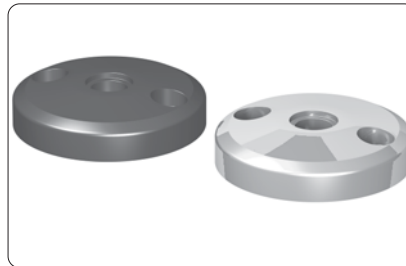

**Technical data**

material:  
GD-Zn: GD-Zn, black powder-coated  
stainless: stainless steel 1.4305  
pickled and passivated  
F = static load max. in kN

**Comments**

Fixing drilling with counterbore DIN 74 - M8 for cap-screw DIN 6912-M8

- S = height of:
- anti-slip disc (S = 2 mm)
  - cushion element (S = 10 mm)

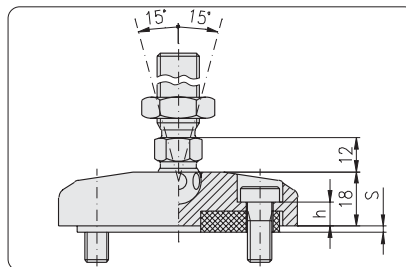
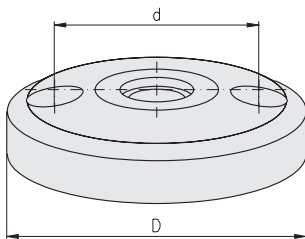

Design with mounting holes

**GD-Zn**

Description	D	h	d	F	Weight	Article-No.
Adjustable tilt-foot plate steel, 80	Ø79	11.5	Ø54	30 kN	260 g	1.44.432080
Adjustable tilt-foot plate steel, 100	Ø99	11.5	Ø74	35 kN	377 g	1.44.432100
Adjustable tilt-foot plate steel, 120	Ø119	11.5	Ø94	35 kN	570 g	1.44.432120

**Stainless steel**

**C R**

Adjustable tilt-foot plate stainl., 80	Ø79	11.0	Ø54	30 kN	354 g	1.44.432080V
Adjustable tilt-foot plate stainl., 100	Ø99	11.0	Ø74	40 kN	587 g	1.44.432100V
Adjustable tilt-foot plate stainl., 120	Ø119	11.0	Ø94	40 kN	830 g	1.44.432120V

## Adjustable tilt-foot spindles



### Technical data

material:  
 steel: steel, galvanised  
 stainless: stainless steel 1.4305,  
 pickled and passivated

**Steel**

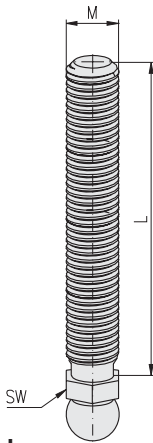

**Stainless steel**

**C R**

Description	G × L	SW	Weight	Article-No.
Adjustable tilt-foot spindle, steel	M8 × 40	14	17 g	1.44.4608040
Adjustable tilt-foot spindle, steel	M8 × 80	14	31 g	1.44.4608080
Adjustable tilt-foot spindle, steel	M10 × 45	14	37 g	1.44.4610045
Adjustable tilt-foot spindle, steel	M10 × 90	14	51 g	1.44.4610090
Adjustable tilt-foot spindle, steel	M12 × 66	14	56 g	1.44.4612066
Adjustable tilt-foot spindle, steel	M12 × 100	14	79 g	1.44.4612100
Adjustable tilt-foot spindle, steel	M14 × 66	14	87 g	1.44.4614066
Adjustable tilt-foot spindle, steel	M14 × 100	14	119 g	1.44.4614100
Adjustable tilt-foot spindle, steel	M14 × 150	14	166 g	1.44.4614150
Adjustable tilt-foot spindle, steel	M16 × 66	17	111 g	1.44.4616066
Adjustable tilt-foot spindle, steel	M16 × 100	17	155 g	1.44.4616100
Adjustable tilt-foot spindle, steel	M16 × 150	17	220 g	1.44.4616150
Adjustable tilt-foot spindle, steel	M20 × 100	21	237 g	1.44.4620100
Adjustable tilt-foot spindle, steel	M20 × 150	21	331 g	1.44.4620150
Adjustable tilt-foot spindle, stainless	M14 × 66	14	87 g	1.44.4614066V
Adjustable tilt-foot spindle, stainless	M14 × 88	14	104 g	1.44.4614088V
Adjustable tilt-foot spindle, stainless	M14 × 100	14	119 g	1.44.4614100V
Adjustable tilt-foot spindle, stainless	M14 × 125	14	138 g	1.44.4614125V
Adjustable tilt-foot spindle, stainless	M14 × 150	14	166 g	1.44.4614150V

## Adjustable tilt-foot nuts



### Technical data

material:  
 steel: steel, galvanised  
 stainless: stainless steel 1.4305,  
 pickled and passivated

**Steel**

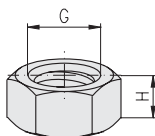

**Stainless steel**

**C R**

Description	G	H	Weight	Article-No.
Adjustable tilt-foot nut	M8	5	5 g	1.44.46M08
Adjustable tilt-foot nut	M10	6	8 g	1.44.46M10
Adjustable tilt-foot nut	M12	7	10 g	1.44.46M12
Adjustable tilt-foot nut	M14	8	16 g	1.44.46M14
Adjustable tilt-foot nut	M16	8	17 g	1.44.46M16
Adjustable tilt-foot nut	M20	9	35 g	1.44.46M20
Adjustable tilt-foot nut, stainless	M14	8	16 g	1.44.46M14V

## Adjustable tilt-foot anti-slip discs

C



### Application

Element for protection against dislocation and floor damage

### Technical data

material: NBR, oil and water resistant  
 colour: black  
 hardness: 80 Shore A  
 F = static load max. in KN

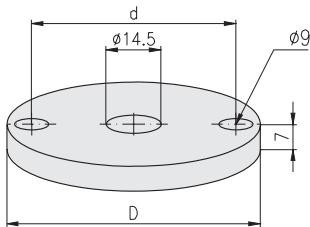
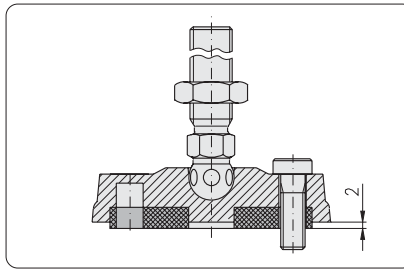

### Description

	D	d	F	Weight	Article-No.
Adj. tilt-foot anti-slip disc for plate 30	Ø20	-	5 kN	2.0 g	1.44.471030
Adj. tilt-foot anti-slip disc for plate 40	Ø30	-	6 kN	4.0 g	1.44.471040
Adj. tilt-foot anti-slip disc for plate 45	Ø35	-	7 kN	5.5 g	1.44.471045
Adj. tilt-foot anti-slip disc for plate 50	Ø39	-	8 kN	7.5 g	1.44.471050
Adj. tilt-foot anti-slip disc for plate 60	Ø49	-	9 kN	12.0 g	1.44.471060
Adj. tilt-foot anti-slip disc for plate 80	Ø67	Ø54	10 kN	22.0 g	1.44.471080
Adj. tilt-foot anti-slip disc for plate 100	Ø87	Ø74	10 kN	36.0 g	1.44.471100
Adj. tilt-foot anti-slip disc for plate 120	Ø107	Ø94	10 kN	57.0 g	1.44.471120

## Adjustable tilt-foot cushion elements

C



### Application

Cushion elements

### Technical data

material: NBR, oil and water resistant  
 colour: black  
 hardness: 70 Shore A  
 F = static load max. in N

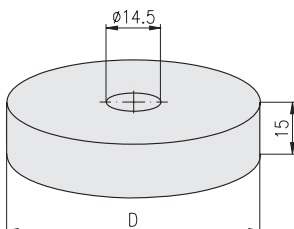
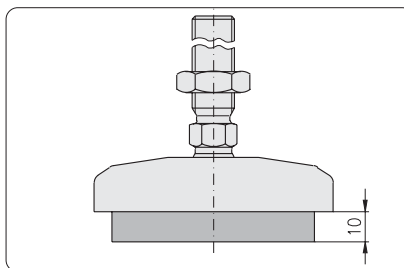

### Description

	D	F	Weight	Article-No.
Adj. tilt-foot cushion element for plate 40	Ø30	150 N	14 g	1.44.472040
Adj. tilt-foot cushion element for plate 45	Ø35	175 N	19 g	1.44.472045
Adj. tilt-foot cushion element for plate 50	Ø39	200 N	24 g	1.44.472050
Adj. tilt-foot cushion element for plate 60	Ø49	250 N	35 g	1.44.472060
Adj. tilt-foot cushion element for plate 80	Ø67	500 N	68 g	1.44.472080
Adj. tilt-foot cushion element for plate 100	Ø87	800 N	118 g	1.44.472100
Adj. tilt-foot cushion element for plate 120	Ø107	1,200 N	188 g	1.44.472120

**Angular adjusting feet**



**Application**

For fastening of frames to floor or wall

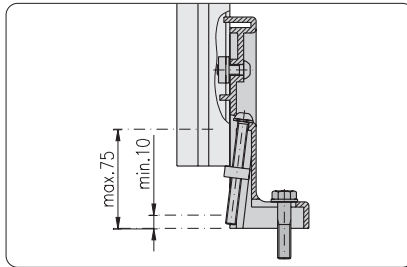

**Technical data**

material:

- base body: GD-Al, black
- nuts: steel galvanised
- screws: steel galvanised
- max. static load: 10,000 N

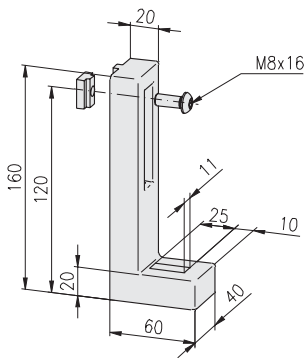

**Delivery unit**

- base body
- nut M8
- screw M8x16 - 10.9

**Description**

Angular adjusting foot without adjusting screw

**Weight**

**Article-No.**

236 g

1.44.716001

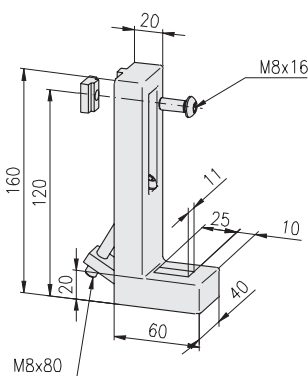

**Delivery unit:**

- base body
- nut M8
- screw M8x16 - 10.9
- screw M8x80 - 10.9
- square nut

**Description**

Angular adjusting foot with adjusting screw

**Weight**

**Article-No.**

264 g

1.44.716002

**Base foot  
for profile 40x40**



**Application**

Base feet for fastening profiles and frames to floor or wall

**Technical data**

material: GD-Zn

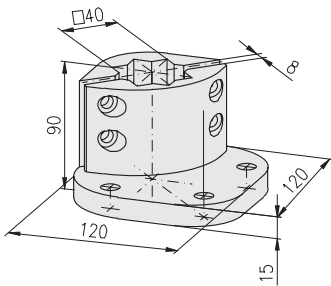
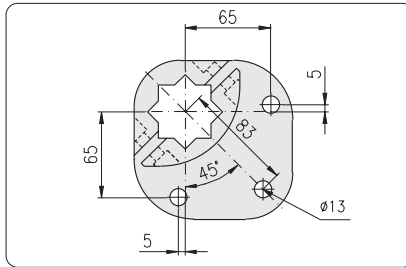

**Description**

Base foot for profile 40x40

**Weight**

979 g

**Article-No.**

1.44.83040

**Floor mounting set**

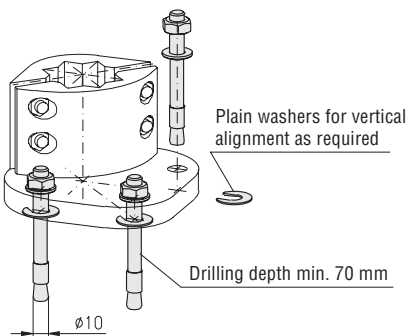

**Description**

Floor mounting set 3 MKT

**Weight**

202.3 g

**Article-No.**

1.44.83BB

**Single parts**

Pin anchor MKT, B10/20/95

**Pcs.**

3

**Weight**

65.3 g

**Article-No.**

0.66.MKT.B1020/95

Plain washer 1xØ24/11

8

0.8 g

1.44.89011324

**Base feet**



**Application**

Base feet for fastening profiles and frames to floor or wall

**Technical data**

material: GK AlZn 10Si8Mg

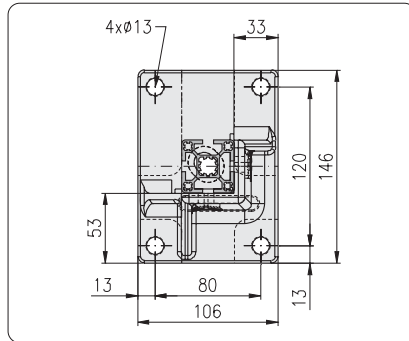
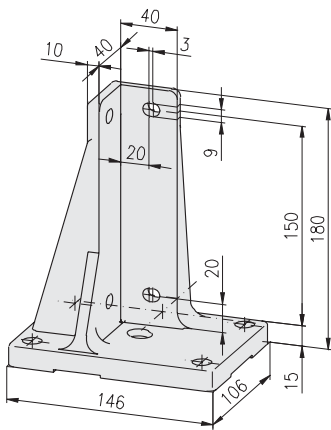

40x40, type 1, left

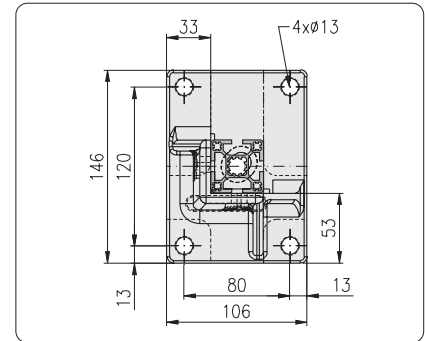

40x40, type 1, right

**Comments**

3D picture shows type 1, right mirror-inverted: type 1, left

**Mounting sets (↔ 185, 186)**

Floor mounting set 4 MKT  
Profile mounting set 4 EM8

**Description**

Description	for profile	Weight	Article-No.
Base foot 40x40, type 1, left	40x40, 45x45	1.06 kg	1.44.84.4040.00L
Base foot 40x40, type 1, right	40x40, 45x45	1.06 kg	1.44.84.4040.00R

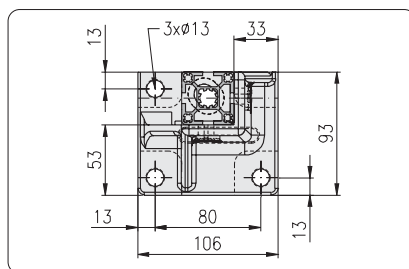
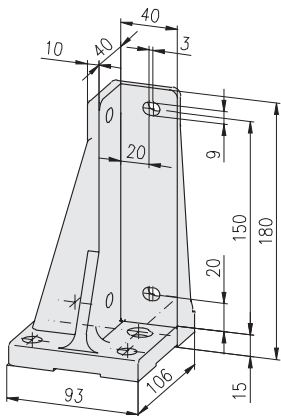

40x40, type 2, left

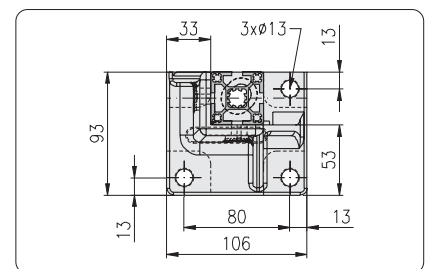

40x40, type 2, right

**Comments**

3D picture shows type 2, right mirror-inverted: type 2, left

**Mounting sets (↔ 185, 186)**

Floor mounting set 3 MKT  
Profile mounting set 4 EM8

**Description**

Description	for profile	Weight	Article-No.
Base foot 40x40, type 2, left	40x40	0.83 kg	1.44.84.4040.40L
Base foot 40x40, type 2, right	40x40	0.83 kg	1.44.84.4040.40R



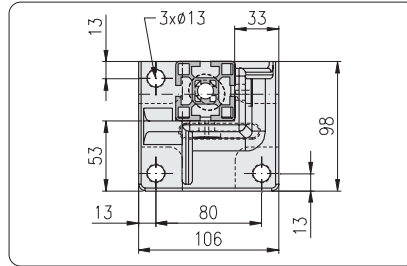
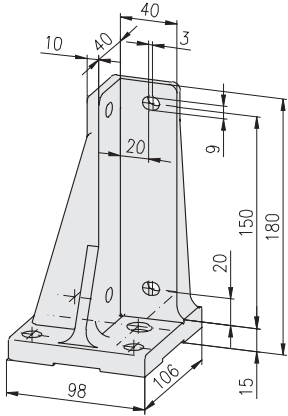

45x45, type 2, left

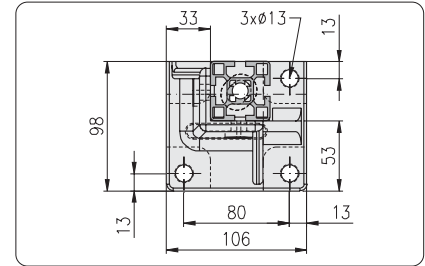

45x45, type 2, right

**Comments**

3D picture shows type 2, right  
mirror-inverted: type 2, left

**Mounting sets (↔ 185, 186)**

Floor mounting set 3 MKT  
Profile mounting set 4 EM8

Description	for profile	Weight	Article-No.
Base foot 45x45, type 2, left	45x45	0.85 kg	1.44.84.4545.45L
Base foot 45x45, type 2, right	45x45	0.85 kg	1.44.84.4545.45R

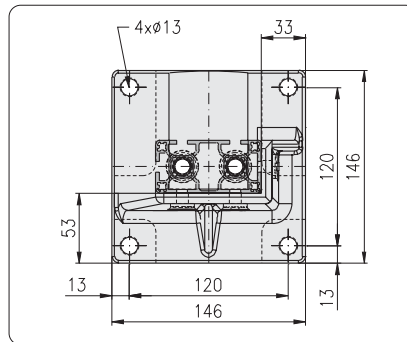
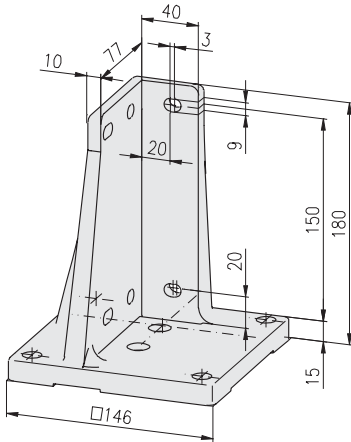

40x80, type 1, left

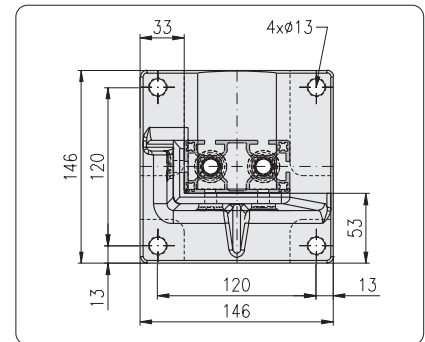

40x80, type 1, right

**Comments**

3D picture shows type 1, right  
mirror-inverted: type 1, left

**Mounting sets (↔ 185, 186)**

Floor mounting set 4 MKT  
Profile mounting set 6 EM8

Description	for profile	Weight	Article-No.
Base foot 40x80, type 1, left	40x80, 60x80, 45x90	1.39 kg	1.44.84.4080.00L
Base foot 40x80, type 1, right	40x80, 60x80, 45x90	1.39 kg	1.44.84.4080.00R

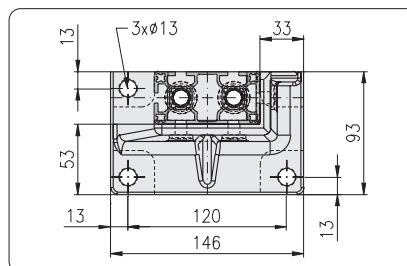
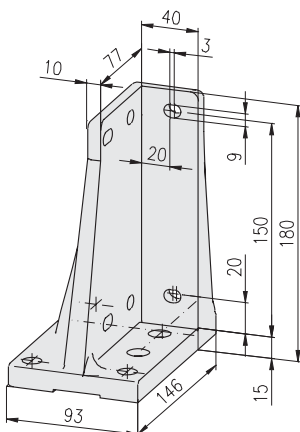

40x80, type 2, left

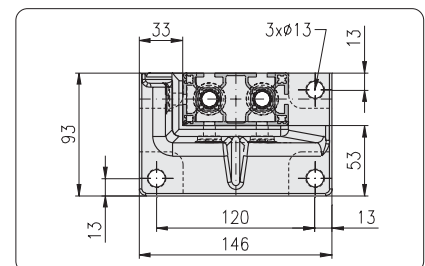

40x80, type 2, right

**Comments**

3D picture shows type 2, right  
mirror-inverted: type 2, left

**Mounting sets (↔ 185, 186)**

Floor mounting set 3 MKT  
Profile mounting set 6 EM8

Description	for profile	Weight	Article-No.
Base foot 40x80, type 2, left	40x80	1.01 kg	1.44.84.4080.40L
Base foot 40x80, type 2, right	40x80	1.01 kg	1.44.84.4080.40R

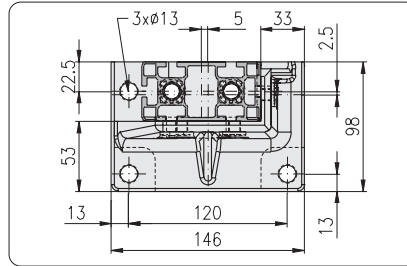
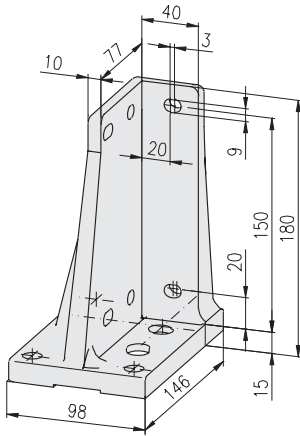

45x90, type 2, left

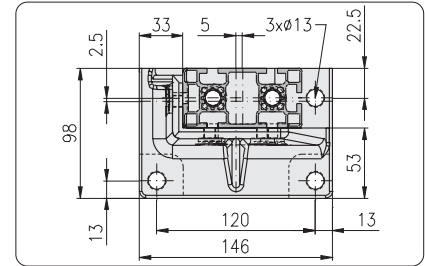

45x90, type 2, right

**Comments**

3D picture shows type 2, right  
mirror-inverted: type 2, left

**Mounting sets (↔ 185, 186)**

Floor mounting set 3 MKT  
Profile mounting set 6 EM8

Description	for profile	Weight	Article-No.
Base foot 45x90, type 2, left	45x90	1.10 kg	1.44.84.4590.45L
Base foot 45x90, type 2, right	45x90	1.10 kg	1.44.84.4590.45R

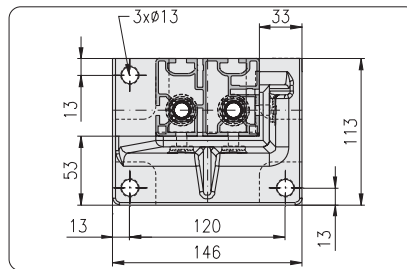
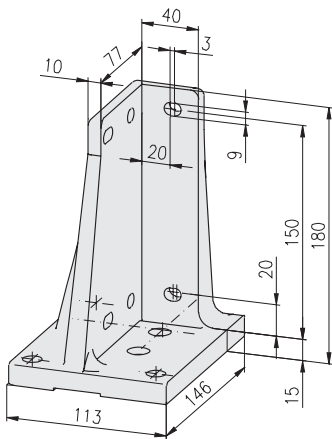

60x80, type 2, left

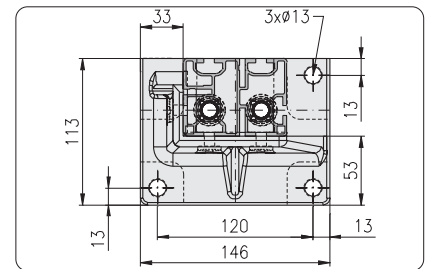

60x80, type 2, right

**Comments**

3D picture shows type 2, right  
mirror-inverted: type 2, left

**Mounting sets (↔ 185, 186)**

Floor mounting set 3 MKT  
Profile mounting set 6 EM8

Description	for profile	Weight	Article-No.
Base foot 60x80, type 2, left	60x80	1.25 kg	1.44.84.6080.60L
Base foot 60x80, type 2, right	60x80	1.25 kg	1.44.84.6080.60R

## Floor mounting sets

Cross-reference list for base feet and floor mounting sets			
Base foot	Article-No.	Floor mounting set	
		3 MKT, 1.44.83BB	4 MKT, 1.44.84BB
40×40, type 1, le/ri	1.44.84.4040.00x		•
40×40, type 2, le/ri	1.44.84.4040.40x	•	
40×80, type 1, le/ri	1.44.84.4080.00x		•
40×80, type 2, le/ri	1.44.84.4080.40x	•	
45×45, type 2, le/ri	1.44.84.4545.45x	•	
45×90, type 2, le/ri	1.44.84.4590.45x	•	
60×80, type 2, le/ri	1.44.84.6080.60x	•	

### Comments

- Drilling depth min. 70 mm
- Plain washers for vertical alignment as required

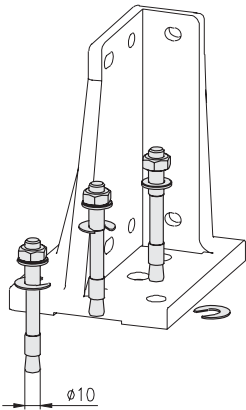

Description	Weight	Article-No.
Floor mounting set 3 MKT	202.3 g	1.44.83BB

Single parts	Pcs.	Weight	Article-No.
Pin anchor MKT, B10/20/95	3	65.3 g	0.66.MKT.B1020/95
Plain washer 1×Ø24/11	8	0.8 g	1.44.89011324

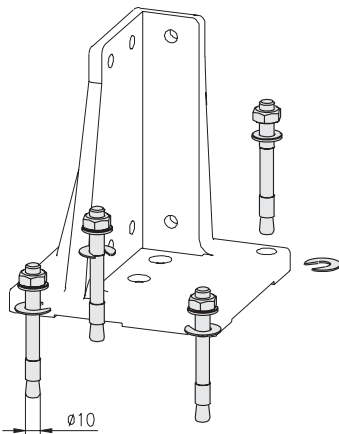

Description	Weight	Article-No.
Floor mounting set 4 MKT	269.2 g	1.44.84BB

Single parts	Pcs.	Weight	Article-No.
Pin anchor MKT, B10/20/95	4	65.3 g	0.66.MKT.B1020/95
Plain washer 1×Ø24/11	10	0.8 g	1.44.89011324

**Profile mounting sets**

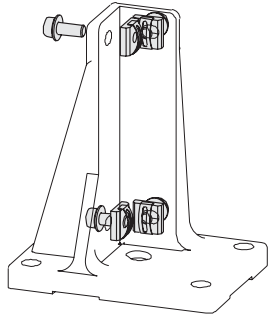
**Application**

Suitable for mounting of the profiles:

- 40×40
- 45×45

Description	Weight	Article-No.
Profile mounting set 4 EM8	112.4 g	1.44.80BP40.20
Single parts	Pcs.	Weight
Threaded plate, heavy, E M8	4	16.3 g
Collar screw W 251 M8×20	4	11.8 g

**Application**

Suitable for mounting of the profiles:

- 40×80
- 45×90
- 60×80, panel

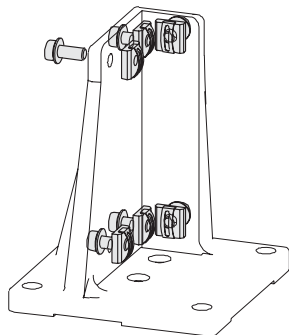

Description	Weight	Article-No.
Profile mounting set 6 EM8	168.6 g	1.44.80BP80.20
Single parts	Pcs.	Weight
Threaded plate, heavy, E M8	6	16.3 g
Collar screw W 251 M8×20	6	11.8 g

**Base angle**

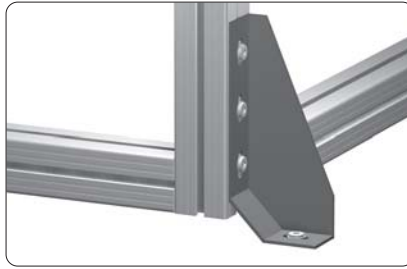

**Application**

For fastening of frames to floor or wall



Suitable for use together with levelling feet with max. diameter 100 mm

**Technical data**

material: sheet steel  
surface: galvanised and black coated

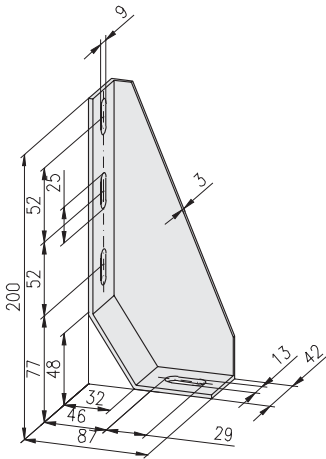

**Description**

Base angle 200x87x42

**Weight**

413 g

**Article-No.**

1.44.820001

**Stacking foot**



**Application**

Element to fix 2 profiles in core hole

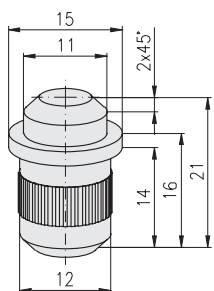
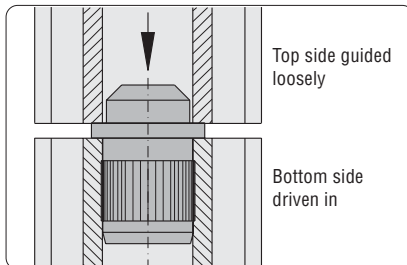

**Technical data**

material: steel  
surface: galvanised

**Description**

Stacking foot

**Weight**

19 g

**Article-No.**

1.44.901221

**Castors**

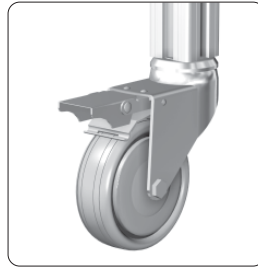

Fastening in core hole

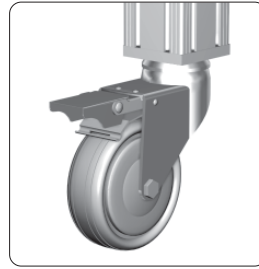

Fastening through base plate for profile without centric core hole

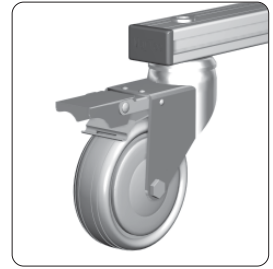

Fastening by press-fit threaded insert across the profile

Variations		
Castor-Ø	50 mm / 75 mm	100 mm / 125 mm
Bolt hole type	 s = 7 mm	 s = 10.5 mm
Fitting plate type	 s = 2 mm	 s = 3 mm

**Fixed castors**

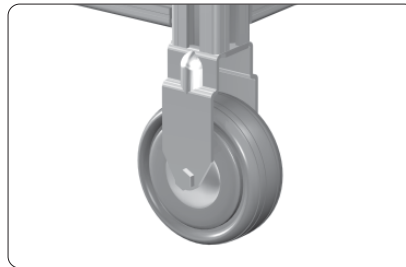

**Technical data**

material:

- capsule: sheet steel, galvanised
- wheels: solid rubber tyres, grey

Ø75/100/125 incl. thread protection

max. static load:  $F_{max}$

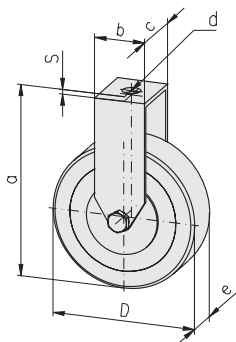

Description	D	a	Weight	Article-No.
Fixed castor with bolt hole	Ø50	69	130 g	1.45.11050
Fixed castor with bolt hole	Ø75	98	240 g	1.45.11075
Fixed castor with bolt hole	Ø100	133	500 g	1.45.11100
Fixed castor with bolt hole	Ø125	158	900 g	1.45.11125
Fixed castor with fitting plate	Ø50	71	190 g	1.45.12050
Fixed castor with fitting plate	Ø75	100	300 g	1.45.12075
Fixed castor with fitting plate	Ø100	136	610 g	1.45.12100
Fixed castor with fitting plate	Ø125	161	1,010 g	1.45.12125

Design bolt hole						
D	b	c	d	e	s	$F_{max}$
Ø50	30	27	Ø10.5	18	2.0	400 N
Ø75	34	27	Ø10.5	25	2.0	550 N
Ø100	57	43	Ø12.5	32	2.5	800 N
Ø125	57	43	Ø12.5	32	2.5	1.000 N

## Swivel castors

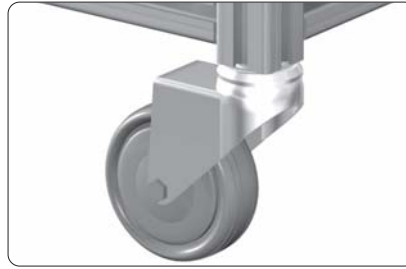

### Technical data

material:

- capsule: sheet steel, galvanised
- wheels: solid rubber tyres, grey

Ø75/100/125 incl. thread protection

max. static load:  $F_{max}$

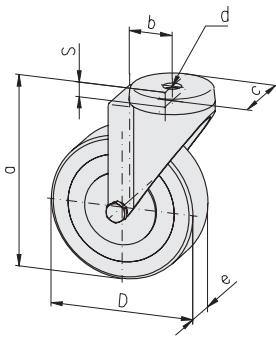

Description	D	a	Weight	Article-No.
Swivel castor with bolt hole	Ø50	69	180 g	1.45.21050
Swivel castor with bolt hole	Ø75	98	310 g	1.45.21075
Swivel castor with bolt hole	Ø100	133	680 g	1.45.21100
Swivel castor with bolt hole	Ø125	158	890 g	1.45.21125
Swivel castor with fitting plate	Ø50	71	230 g	1.45.22050
Swivel castor with fitting plate	Ø75	100	360 g	1.45.22075
Swivel castor with fitting plate	Ø100	136	780 g	1.45.22100
Swivel castor with fitting plate	Ø125	161	990 g	1.45.22125

Dimensions see table below

## Swivel castors lockable



### Technical data

material:

- capsule: sheet steel, galvanised
- wheels: solid rubber tyres, grey

stop fix: - wheel break  
- swivel break

Ø75/100/125 incl. thread protection

max. static load:  $F_{max}$

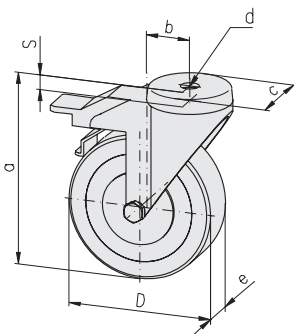

Description	D	a	Weight	Article-No.
Swivel castor, lockable with bolt hole	Ø50	69	220 g	1.45.31050
Swivel castor, lockable with bolt hole	Ø75	98	450 g	1.45.31075
Swivel castor, lockable with bolt hole	Ø100	133	840 g	1.45.31100
Swivel castor, lockable with bolt hole	Ø125	158	990 g	1.45.31125
Swivel castor, lockable with fitting plate	Ø50	71	270 g	1.45.32050
Swivel castor, lockable with fitting plate	Ø75	100	500 g	1.45.32075
Swivel castor, lockable with fitting plate	Ø100	136	940 g	1.45.32100
Swivel castor, lockable with fitting plate	Ø125	161	1,090 g	1.45.32125

Design bolt hole						
D	b	c	d	e	s	$F_{max}$
Ø50	25	Ø43	Ø10.5	18	10.5	400 N
Ø75	30.5	Ø43	Ø10.5	25	10.5	550 N
Ø100	43	Ø57	Ø12.5	32	10.5	800 N
Ø125	43	Ø57	Ø12.5	32	10.5	1,000 N

**Locking castors**



**Application**

Locking castors for easy movement and positioning of trolleys, benches and assemblies

**Technical data**

material:

- capsule: Al
  - fastening elements: C45
  - locking foot: GD-Al, rubber
- max. static load:  $F_{max}$

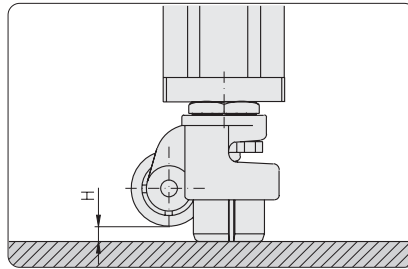

Extended support foot to secure position

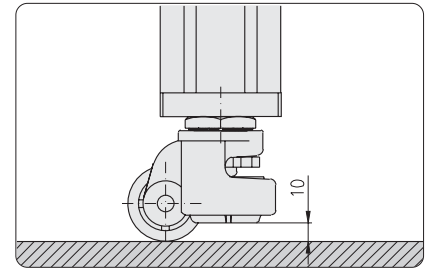

Retracted support foot for easy movement

Design					
D	a	b <sub>max</sub>	c	H <sub>max</sub>	F <sub>max</sub>
Ø50	83	93	98	10	2.000 N
Ø62	102	117	122	15	4.000 N

**Locking castors with plate**

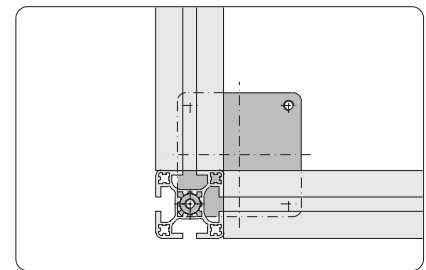
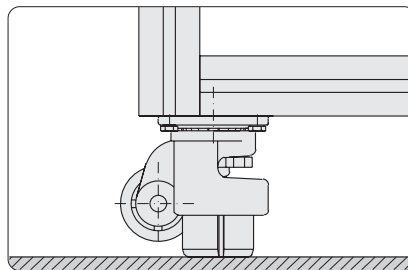

Mounting on profile frame using core hole and slot

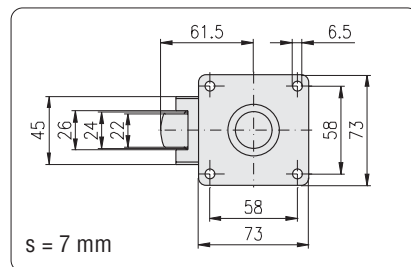

Castor-Ø50

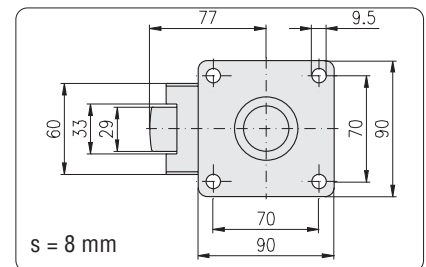

Castor-Ø62

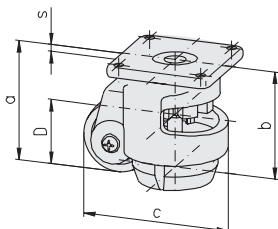

Description	D	Weight	Article-No.
Locking castor 200 kg, with plate	Ø50	760 g	1.45.80200.073
Locking castor 400 kg, with plate	Ø62	1,380 g	1.45.80400.090



**Locking castors with center thread**

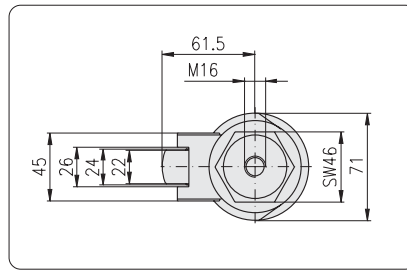
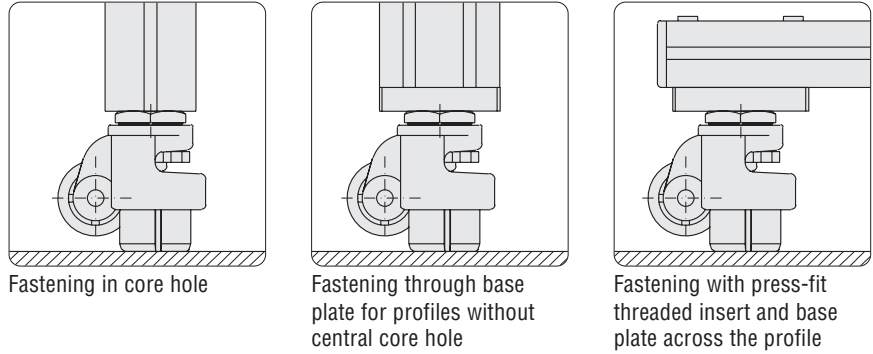

Castor-Ø50

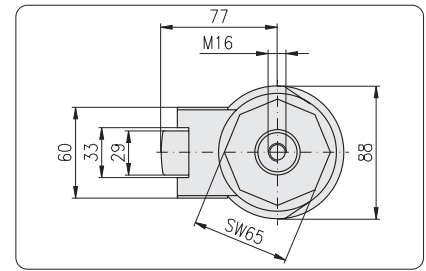

Castor-Ø62

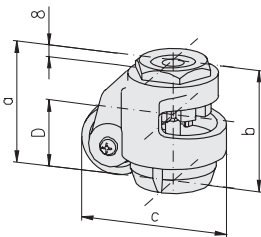

Description	D	Weight	Article-No.
Locking castor 200 kg, with center thread	Ø50	760 g	1.45.81200.046
Locking castor 400 kg, with center thread	Ø62	1,380 g	1.45.81400.065

**Threaded bolt for locking castor with center thread**

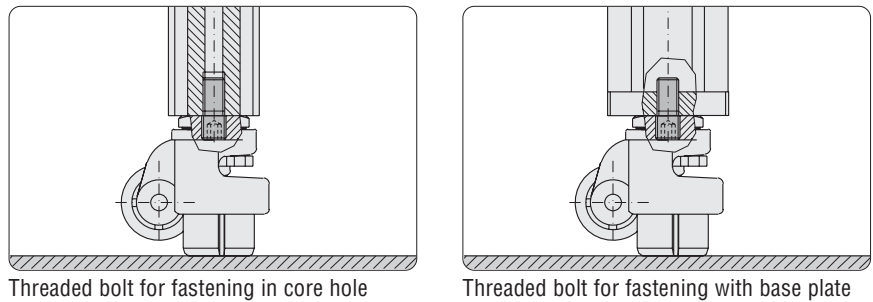

**Application**  
 For fastening of locking castors with central thread

- in core hole-Ø12 of the profile
- on base plate

**Technical data**  
 material: steel  
 surface: galvanised

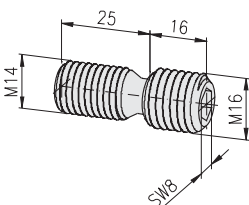

Description	Weight	Article-No.
Threaded bolt M16/M14	28 g	1.45.81000.M16M14

**Angles 25x40**

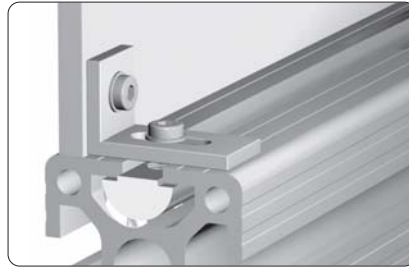

Fastening of panels

**Application**

Angle bracket for the mounting of panels, table tops, switches and accessories

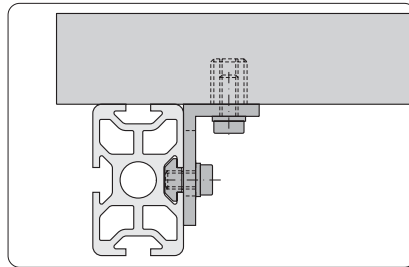

Fastening of table tops

**Technical data**

material: aluminium  
 strength: F22  
 surface: neutral anodised

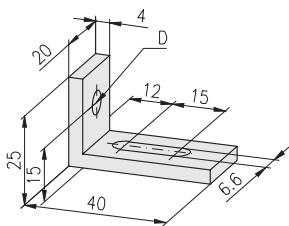

**Comments**

Design with clearance hole drilling

Description	D	Weight	Article-No.
Angle 25x40	Ø6.6	11 g	1.46.110
Angle 25x40	Ø8.7	10 g	1.46.115

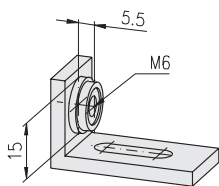

**Comments**

Design with nut M6 ± 0.5 mm floating in cage

Description	Weight	Article-No.
Angle 25x40, M6	15 g	1.46.120

**Angles PA**

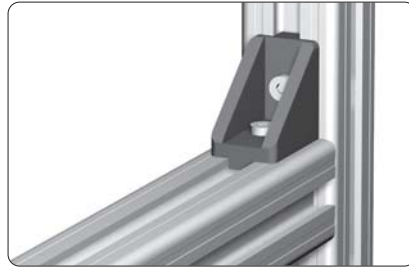

Support of free-standing profiles

**Application**

For supporting of profiles and mounting of cover panels



Support across the profile  
In this application the rotary lock must be removed from one side

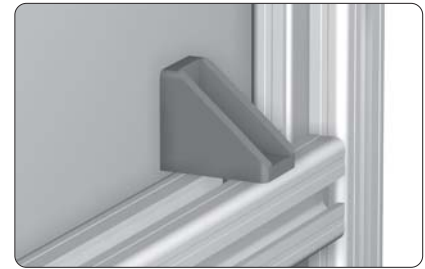

Mounting of cover panels  
In this application the rotary lock must be removed from both sides

**Technical data**

material: PA-GF

**20x28**

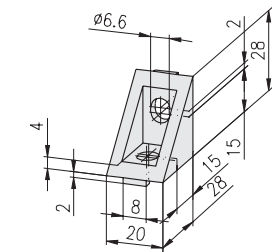

Description	Colour	Weight	Article-No.
Angle PA, 20x28	grey	6.4 g	1.46.203.2028.1
Angle PA, 20x28	black	6.4 g	1.46.203.2028.2

**30x38**

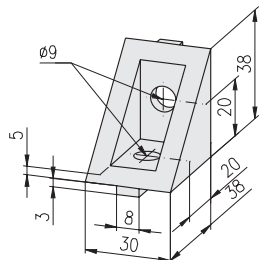

Description	Colour	Weight	Article-No.
Angle PA, 30x38	grey	18.9 g	1.46.203.3038.1
Angle PA, 30x38	black	18.9 g	1.46.203.3038.2

## Angles GD-Zn



### Application

For supporting profiles and mounting various machine components

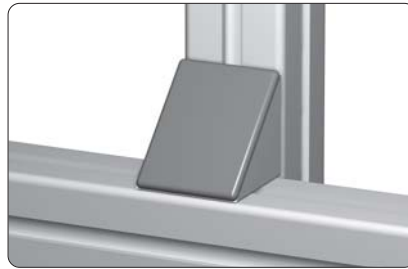

### Technical data

material:

- angle: GD-Zn
- cover cap: PA-GK 30
- T-slot nut: steel, galvanised
- screw: steel, galvanised
- surface: natural or aluminium coloured powder-coated

For mounting cross to the slot the noses can be broken off

## 17x20

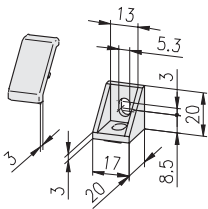

Description	Surface	Weight	Article-No.
Angle GD-Zn, 17x20	natural	13.7 g	1.46.204.1720.1
Angle GD-Zn, 17x20	powder-coated	13.7 g	1.46.204.1720.2
Cover cap for angle GD-Zn, 17x20		1.7 g	1.46.204.1720A
Angle connection set	1720 H/H	20.9 g	1.46.204.1720.□HH
Angle connection set	1720 H/F	23.6 g	1.46.204.1720.□HF
Angle connection set	1720 F/F	26.3 g	1.46.204.1720.□FF
Angle connection set	1720 T H/F	25.0 g	1.46.204.1720T□HF
Angle connection set	1720 T F/F	29.1 g	1.46.204.1720T□FF

Single parts: Angle connection sets 1720					
Angle	Slot	Fastening elements			
	H	threaded plate		lens head screw	Pcs.
	F	T-slot nut			
1.46.204.1720.□	H	H	1.314.HM5	0.63.WN7381.05006	2
1.46.204.1720.□	H	H	1.314.HM5	0.63.WN7381.05006	1
		F	1.34.10FM5	0.63.WN7381.05008	1
1.46.204.1720.□	F	F	1.34.10FM5	0.63.WN7381.05008	2



Single parts: Angle connection sets 1720 T					
Angle	Slot	Fastening elements			
	H	threaded plate		lens head screw	Pcs.
	F	T-nut for subs. insertion			
1.46.204.1720□	H	H	1.314.HM5	0.63.WN7381.05006	1
		F	1.324.FM5	0.63.WN7381.05008	1
1.46.204.1720□	F	F	1.324.FM5	0.63.WN7381.05008	2

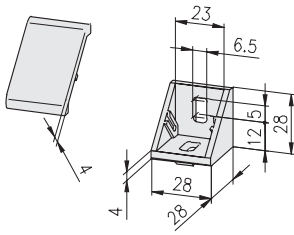

- 1 angle natural
- 2 angle powder-coated

## 28x28



Description	Surface	Weight	Article-No.
Angle GD-Zn, 28x28	natural	39.6 g	1.46.204.2828.1
Angle GD-Zn, 28x28	powder-coated	39.6 g	1.46.204.2828.2
Cover cap for angle GD-Zn, 28x28		5.6 g	1.46.204.2828A
Angle connection set	2828 F/F	56.4 g	1.46.204.2828.□FF
Angle connection set	2828 F/E	56.8 g	1.46.204.2828.□FE
Angle connection set	2828 E/E	57.2 g	1.46.204.2828.□EE
Angle connection set	2828 T F/F	59.8 g	1.46.204.2828T□FF
Angle connection set	2828 T F/E	66.3 g	1.46.204.2828T□FE
Angle connection set	2828 T E/E	72.8 g	1.46.204.2828T□EE



Single parts: Angle connection sets 2828						
Angle	Slot	Fastening elements				
		T-slot nut		lens head screw		Pcs.
1.46.204.2828.□	F F	1.34.10FM6		0.63.WN7381.06010		2
1.46.204.2828.□	F E	1.34.10FM6		0.63.WN7381.06010		1
		1.34.10EM6		0.63.WN7381.06012		1
1.46.204.2828.□	E E	1.34.10EM6		0.63.WN7381.06012		2

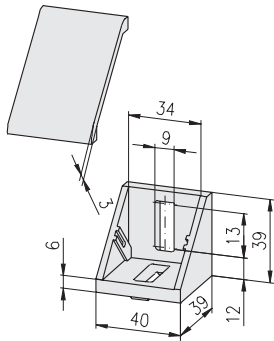

Single parts: Angle connection sets 2828 T						
Angle	Slot	Fastening elements				
		T-nut for subs. insertion		lens head screw		Pcs.
1.46.204.2828□	F F	1.324.FM6		0.63.WN7381.06010		2
1.46.204.2828□	F E	1.324.FM6		0.63.WN7381.06010		1
		1.324.EM6		0.63.WN7381.06012		1
1.46.204.2828□	E E	1.324.EM6		0.63.WN7381.06012		2

- 
- 1 angle natural
- 2 angle powder-coated

**40x39**

Description	Surface	Weight	Article-No.
Angle GD-Zn, 40x39	natural	85.5 g	1.46.204.4039.1
Angle GD-Zn, 40x39	powder-coated	85.5 g	1.46.204.4039.2
Cover cap for angle GD-Zn, 40x39		8.0 g	1.46.204.4039A
Angle connection set	4039 F/F	105.9 g	1.46.204.4039.□FF
Angle connection set	4039 F/E	111.9 g	1.46.204.4039.□FE
Angle connection set	4039 E/E	117.9 g	1.46.204.4039.□EE
Angle connection set	4039 T F/F	105.9 g	1.46.204.4039T□FF
Angle connection set	4039 T F/E	111.9 g	1.46.204.4039T□FE
Angle connection set	4039 T E/E	117.9 g	1.46.204.4039T□EE

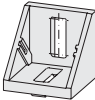
Single parts: Angle connection sets 4039					
Angle	Slot	Fastening elements			
		T-screw		hexagon flange nut	Pcs.
1) 1.46.204.4039.□	F F	1.34.30FM820		0.61.D06923.08	2
1.46.204.4039.□	F E	1.34.30FM820		0.61.D06923.08	1
		1.34.30EM820		0.61.D06923.08	1
1.46.204.4039.□	E E	1.34.30EM820		0.61.D06923.08	2

Single parts: Angle connection sets 4039 T					
Angle	Slot	Fastening elements			
		T-nut for subs. insertion		lens head screw	Pcs.
1.46.204.4039□	F F	1.324.FM8		0.63.WN7381.08012	2
1.46.204.4039□	F E	1.324.FM8		0.63.WN7381.08012	1
		1.324.EM8		0.63.WN7381.08016	1
1.46.204.4039□	E E	1.324.EM8		0.63.WN7381.08016	2



- 1 angle natural  
 2 angle powder-coated

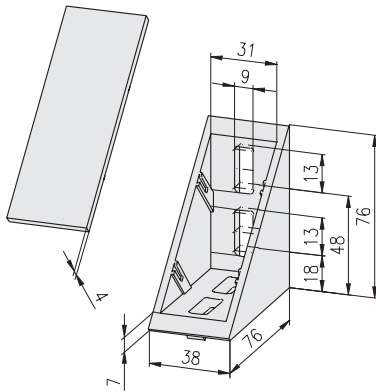

- 1) Connection with T-screw only without cover cap

## 38x76

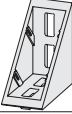

Description	Surface	Weight	Article-No.
Angle GD-Zn, 38x76	natural	273.0 g	1.46.204.3876.1
Angle GD-Zn, 38x76	powder-coated	273.0 g	1.46.204.3876.2
Cover cap for angle GD-Zn, 38x76		16.8 g	1.46.204.3876A
Angle connection set	3876 F/F	334.2 g	1.46.204.3876.□FF
Angle connection set	3876 F/E	342.2 g	1.46.204.3876.□FE
Angle connection set	3876 E/E	350.2 g	1.46.204.3876.□EE
Angle connection set	3876 T F/F	313.8 g	1.46.204.3876T□FF
Angle connection set	3876 T F/E	325.8 g	1.46.204.3876T□FE
Angle connection set	3876 T E/E	337.8 g	1.46.204.3876T□EE





Single parts: Angle connection sets 3876					
Angle	Slot	Fastening elements			
		T-screw		hexagon flange nut	Pcs.
1.46.204.3876.□	F F	1.34.30FM820		0.61.D06923.08	4
1.46.204.3876.□	F E	1.34.30FM820		0.61.D06923.08	2
	E E	1.34.30EM820		0.61.D06923.08	2
1.46.204.3876.□	E E	1.34.30EM820		0.61.D06923.08	4

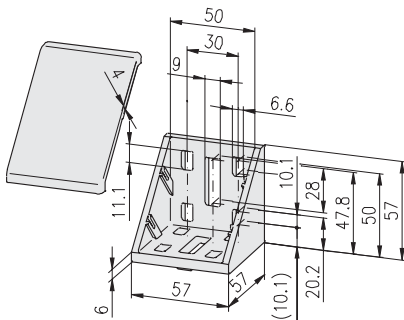

Single parts: Angle connection sets 3876 T					
Angle	Slot	Fastening elements			
		T-nut for subs. insertion		lens head screw	Pcs.
1.46.204.3876□	F F	1.324.FM8		0.63.WN7381.08012	4
1.46.204.3876□	F E	1.324.FM8		0.63.WN7381.08012	2
	E E	1.324.EM8		0.63.WN7381.08016	2
1.46.204.3876□	E E	1.324.EM8		0.63.WN7381.08016	4

- 
- 1 angle natural
- 2 angle powder-coated

**57×57**

Description	Surface	Weight	Article-No.
Angle GD-Zn, 57×57	natural	226.3 g	1.46.204.5757.1
Angle GD-Zn, 57×57	powder-coated	226.3 g	1.46.204.5757.2
Cover cap for angle GD-Zn, 57×57		22.8 g	1.46.204.5757A
Angle connection set	5757 F/F	296.7 g	1.46.204.5757.□FF
Angle connection set	5757 F/E	280.8 g	1.46.204.5757.□FE
Angle connection set	5757 E/E	261.9 g	1.46.204.5757.□EE
Angle connection set	5757 T F/F	246.7 g	1.46.204.5757T□FF
Angle connection set	5757 T F/E	252.7 g	1.46.204.5757T□FE
Angle connection set	5757 T E/E	258.7 g	1.46.204.5757T□EE

Single parts: Angle connection sets 5757						
Angle	Slot	Fastening elements				
	F	T-slot nut		lens head screw		Pcs.
	E	T-screw		hexagon flange nut		
1.46.204.5757.□	F	F	1.34.10FM6	0.63.WN7381.06012	8	
1.46.204.5757.□	F	F	1.34.10FM6	0.63.WN7381.06012	4	
		E	1.34.30EM820	0.61.D06923.08	1	
1.46.204.5757.□	E	E	1.34.30EM820	0.61.D06923.08	2	



Single parts: Angle connection sets 5757 T						
Angle	Slot	Fastening elements				
		T-nut for subs. insertion		lens head screw		Pcs.
1.46.204.5757□	F	F	1.324.FM8	0.63.WN7381.08012	8	
1.46.204.5757□	F	F	1.324.FM8	0.63.WN7381.08012	4	
		E	1.324.EM8	0.63.WN7381.08016	1	
1.46.204.5757□	E	E	1.324.EM8	0.63.WN7381.08016	2	

- 1 angle natural  
 2 angle powder-coated

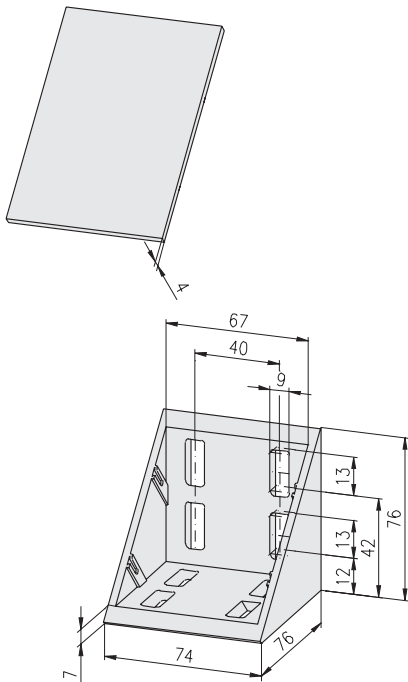

**74x76**

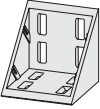
Description	Surface	Weight	Article-No.
Angle GD-Zn, 74x76	natural	434.5 g	1.46.204.7476.1
Angle GD-Zn, 74x76	powder-coated	434.5 g	1.46.204.7476.2
Cover cap for angle GD-Zn, 74x76		32.7 g	1.46.204.7476A
Angle connection set	7476 E/E	588.9 g	1.46.204.7476.□EE

Single parts: Angle connection set 7476				
Angle	Slot	Fastening elements		Pcs.
		T-screw 	hexagon flange nut 	
1.46.204.7476.□	E E	1.34.30EM820	0.61.D06923.08	8

- 1 angle natural  
 2 angle powder-coated

**Angles GD-AI**

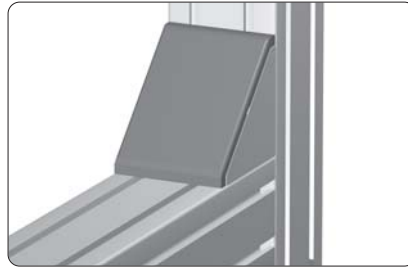

**Application**

For supporting profiles and mounting various machine components

**Technical data**

material:

- angle: GD-AI
- cover cap: PA GK 30
- nut: steel, galvanised
- screw: steel, galvanised
- surface: natural

**42x42**

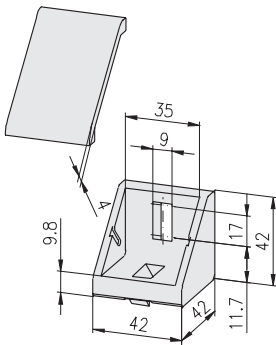

Description	Surface	Weight	Article-No.
Angle GD-AI, 42x42	natural	56.0 g	1.46.204.4242.1AL
Cover cap for angle GD-AI, 42x42		14.0 g	1.46.204.4242.AAL
Angle connection set	4242 E/E	100.0 g	1.46.204.4242.SAL

Single parts: Angle connection set 4242					
Angle	Slot	Fastening elements			Pcs.
		T-screw		hexagon flange nut	
1.46.204.4242.1AL	E E	1.34.30EM820		0.61.D06923.08	2

**88x86**

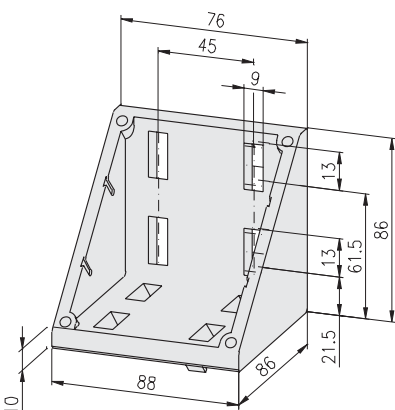
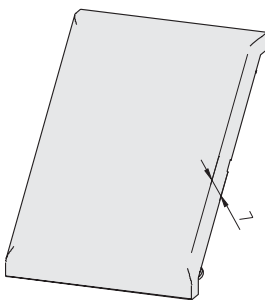

Description	Surface	Weight	Article-No.
Angle GD-AI, 88x86	natural	333.8 g	1.46.204.8886.1AL
Cover cap for angle GD-AI, 88x86		30.0 g	1.46.204.8886.AAL
Angle connection set	8886 E/E	485.5 g	1.46.204.8886.SAL

Single parts: Angle connection set 8886					
Angle	Slot	Fastening elements			Pcs.
		T-screw		hexagon flange nut	
1.46.204.8886.1AL	E E	1.34.30EM820		0.61.D06923.08	8

**Angles Alu**



Mounting of cover panels

**Application**

For supporting of profiles and mounting of cover panels



Support across the profile

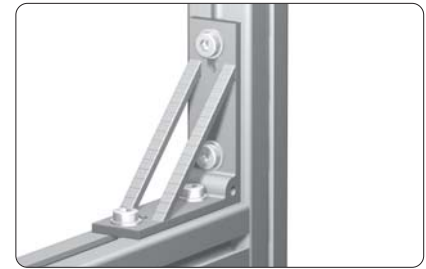

Support of free-standing profiles

**Technical data**

material: aluminium  
 strength: F22  
 surface: neutral anodised

**Comments**

Angles Alu are made from the angle profiles  
 ➔ 1.19.141...

**48x48**

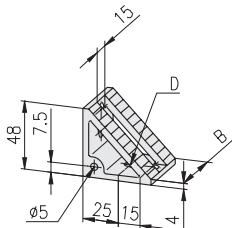

Description	D	B	Weight	Article-No.
Angle 48x48	Ø6.6	30	40 g	1.46.20536
Angle 48x48	Ø9.0	30	38 g	1.46.20539
Angle 48x48	Ø6.6	45	66 g	1.46.20546
Angle 48x48	Ø9.0	45	64 g	1.46.20549

**60x60**

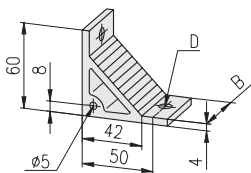

Description	D	B	Weight	Article-No.
Angle 60x60	Ø9.0	30	49 g	1.46.20639
Angle 60x60	Ø9.0	45	74 g	1.46.20649

**100x100**

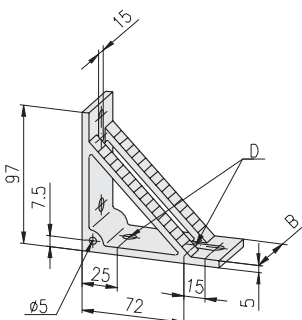

Description	D	B	Weight	Article-No.
Angle 100x100	Ø6.6	30	95 g	1.46.21036
Angle 100x100	Ø9.0	30	93 g	1.46.21039
Angle 100x100	Ø6.6	45	155 g	1.46.21046
Angle 100x100	Ø9.0	45	153 g	1.46.21049

**Swivel angles**

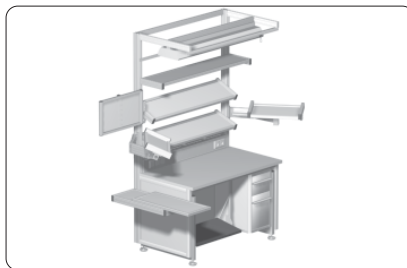

Fastening from below



Fastening from the side

**Application**

Infinitely variable adjusting of inclination with swivel angle

**Technical data**

Design alu:

- material: aluminium
- strength: F22
- surface: neutral anodised

Design steel:

- material: steel
- surface: galvanised

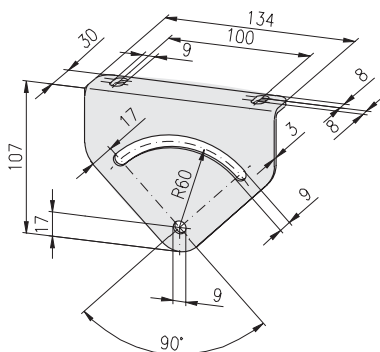
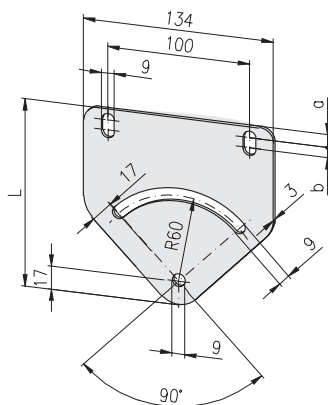

- 16 20 30 40 45 50 60

Description	L	Design	a	b	Weight	Article-No.
Swivel angle	131	alu	8	8.0	105 g	1.46.3012900.AL
Swivel angle	146	alu	13	10.5	116 g	1.46.3014400.AL
Swivel angle	131	steel	8	8.0	320 g	1.46.3012900.ST
Swivel angle	146	steel	13	10.5	360 g	1.46.3014400.ST

Description	Design	Weight	Article-No.
Swivel angle 30	alu	105 g	1.46.3110530.AL
Swivel angle 30	steel	320 g	1.46.3110530.ST

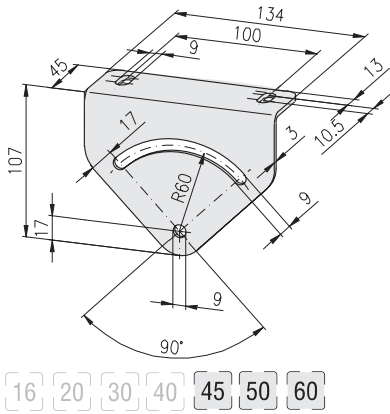

Description	Design	Weight	Article-No.
Swivel angle 45	alu	116 g	1.46.3110545.AL
Swivel angle 45	steel	360 g	1.46.3110545.ST

**Cross connection plates**

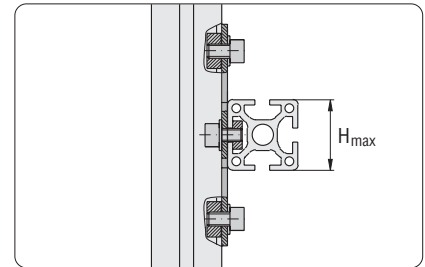
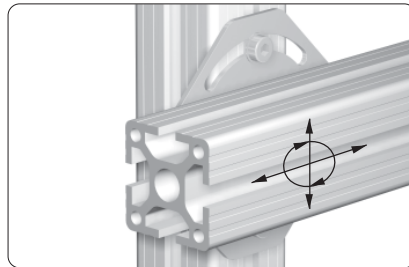

**Application**

The cross connection plate allows profile adjustment in 2 directions and at an angle of  $\pm 45^\circ$

**Technical data**

material: aluminium  
 strength: F22  
 surface: neutral anodised

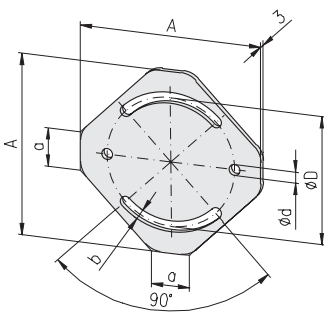

Description	H <sub>max</sub>	Weight	Article-No.
Cross connection plate 65×65	20	20 g	1.47.1065
Cross connection plate 85×85	30	35 g	1.47.1085
Cross connection plate 95×95	30	45 g	1.47.1095
Cross connection plate 125×125	50	80 g	1.47.1125

Type	A	a	b	ØD	Ød
65×65	65	18	5.1	45	5.1
85×85	85	18	5.1	60	5.1
95×95	95	18	6.1	65	6.1
125×125	125	37	8.1	95	8.1

**Base plates**

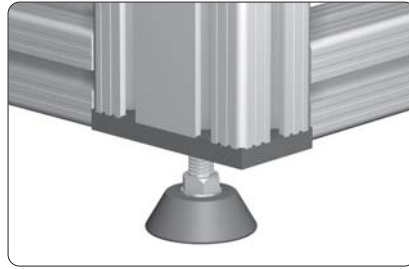

Fastening of levelling feet

**Application**

Base and transporting plate for profiles without centric core hole



Fastening of castors



Fastening of eye-bolts

**Technical data**

Design Alu:

- material: aluminium
- strength: F22
- surface: black powder-coated

Design GD-Zn:

- material: GD-Zn
- surface: black powder-coated

**Accessories**

- threaded insert
- cap-screw DIN 912

**Comments**

Counterbore DIN 74 for cap-screw DIN 912

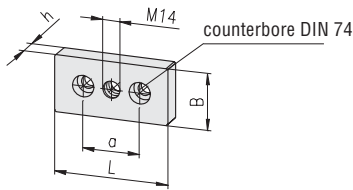

16 20 30 40 45 50 60

Description	B×L	Design	DIN 74	h	a	Weight	Article-No.
Base plate	30×60	GD-Zn M14	- Km6	12	30	104.2 g	1.47.20306
Base plate	40×80	GD-Zn M14	- Km8	16	40	205.2 g	1.47.20408
Base plate	45×90	GD-Zn M14	- Km8	16	45	256.5 g	1.47.2045090
Base plate	50×100	GD-Zn M14	- Km8	16	50	316.8 g	1.47.20510
Base plate	60×90	Alu M14	- Km8	15	45	197.1 g	1.47.2060090

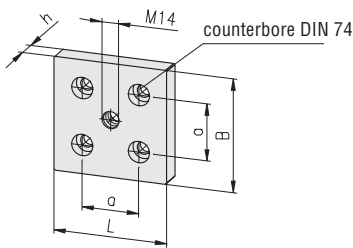

16 20 30 40 45 50 60

Description	B×L	Design	DIN 74	h	a	Weight	Article-No.
Base plate	60×60	GD-Zn M14	- Km8	12	30	158.4 g	1.47.2060060
Base plate	80×80	GD-Zn M14	- Km8	16	40	434.3 g	1.47.20808
Base plate	90×90	GD-Zn M14	- Km8	16	45	520.7 g	1.47.2090090
Base plate	100×100	GD-Zn M14	- Km8	16	50	601.0 g	1.47.21010

**Floor mounting plate**

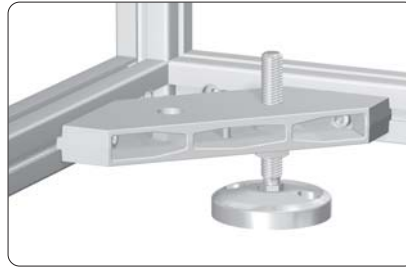

**Application**

For fastening and manual levelling of profile racks and frames

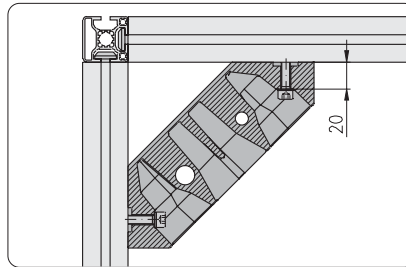

**Technical data**

material: aluminium  
 surface: natural or black powder-coated

**Fastening elements**

- F-slot: 2×T-nut with leaf spring FM8      1.32.FM8  
           2×cap screw M8×25
- E-slot: 2×threaded plate, heavy EM8      1.316.EM8  
           2×cap screw M8×30

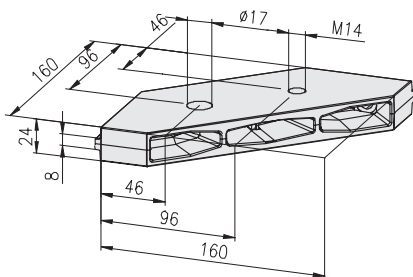

**Description**

Description	Weight	Article-No.
Floor mounting plate, natural	622 g	1.47.225160.1
Floor mounting plate, black powder-coated	622 g	1.47.225160.2

**Mounting plates**



**Application**

Mounting plate for fixing on walls, table tops and machine frames

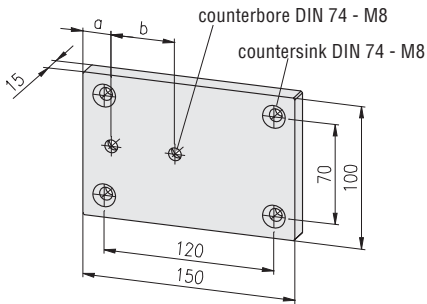

**Technical data**

material: aluminium  
strength: F22  
surface: neutral anodised

**Comments**

Counterbore DIN 74 - M8 for cap-screw DIN 912 - M8  
Countersink DIN 74 - M8 for countersunk screw DIN 7991 - M8

- 16
- 20
- 30
- 40
- 45
- 50
- 60

**Description**

	a	b	Weight	Article-No.
Mounting plate for profile 30x60	15	30	450 g	1.47.30306
Mounting plate for profile 40x80	20	40	450 g	1.47.30408
Mounting plate for profile 50x100	25	50	450 g	1.47.30510

**Floor plate**



**Application**

For fastening and adjusting of vertical profiles to floor and wall

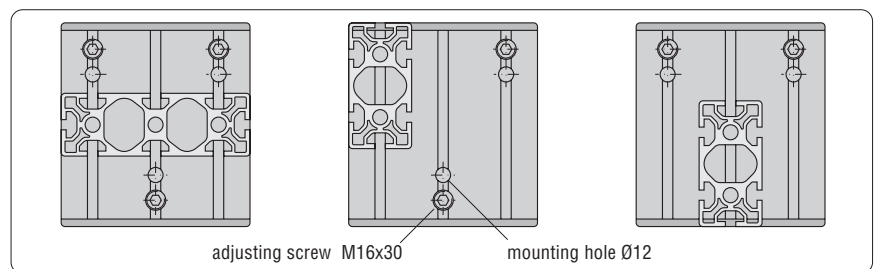

**Fastening variants**

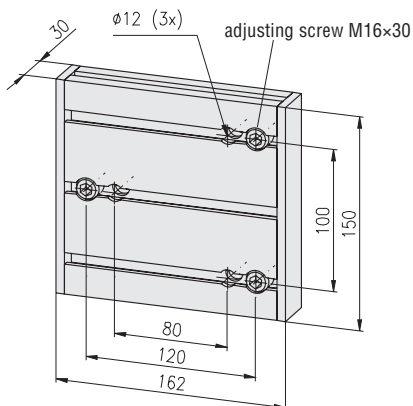

**Technical data**

aluminium profile: anodised  
cover caps: PA-GF black

**Delivery unit:**

- 1 profile 30x150x150
- 2 cover caps
- 3 set screws M16x30

- 16
- 20
- 30
- 40
- 45
- 50
- 60

**Description**

	Weight	Article-No.
Floor plate 30x150x150	1,100 g	1.47.40315



**Connection plates**



Flush connection of 2 profiles without gap



Connection of 2 profiles with gap



Fastening of the electrical trunking



Connection of the pneumatic air manifold

**Application**

- for subsequent or additional connection of profiles
- for fastening of accessories

**Technical data**

material: aluminium  
 strength: F22  
 surface: neutral anodised

**Comments**

Countersink DIN 74 - M6 / M8 for countersunk screw DIN 7991 - M6 / M8

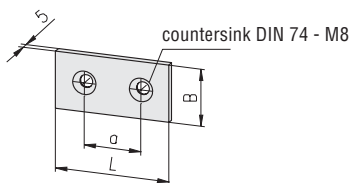

- 16 20 30 40 45 50 60

Description	B×L	Countersink	a	Weight	Article-No.
Connection plate	30×60	DIN 74 - M6	30	28 g	1.47.50306
Connection plate	40×80	DIN 74 - M8	40	38 g	1.47.50408
Connection plate	45×90	DIN 74 - M8	45	45 g	1.47.50459

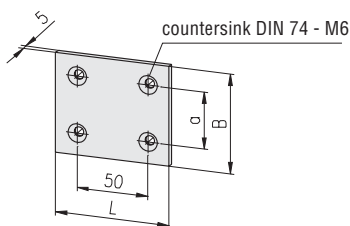

- 16 20 30 40 45 50 60

**Comments**

Countersink DIN 74 - M6 for countersunk screw DIN 7991 - M6

Description	B×L	a	Weight	Article-No.
Connection plate	50×80	30	50 g	1.47.50508
Connection plate	70×80	40	69 g	1.47.50708
Connection plate	75×80	45	76 g	1.47.50758
Connection plate	80×80	50	81 g	1.47.50808

**Fastening plate  
30x150**



Fastening of profile 30x100

Fastening of profile 30x100 with joint 30x100



**Application**

Fastening plate to increase the carrying capacity of detached bracket or swivel arm

- for profile 30x100
- for joint 30x100

**Technical data**

material: aluminium  
strength: F22  
surface: neutral anodised

max. bend-load: $M_b = F \times L$	
vertical profiles	$M_b$
30x30	750 Nm
40x40	1,000 Nm
50x50	1,500 Nm

**Comments**

Counterbore DIN 74 - M8 for cap-screw DIN 6912 - M8

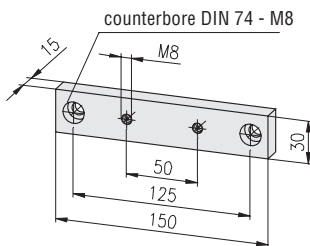

- 16 20 **30** 40 45 50 60

**Description**

Fastening plate 30x150

**Weight**

228 g

**Article-No.**

1.47.60315

**Eye-bolt**



Mounting directly in the profile (core hole)



Mounting with base plates

**Application**

Eye-bolts for the transfer of frames and complete equipment

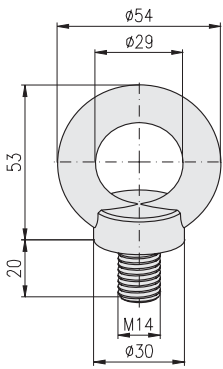

**Technical data**

material: C 15

max. load 1):

- for one eye-bolt 5,000 N
- for two eye-bolts total 7,000 N

1) The max. load given is valid only if the eye-bolt face is tightened firmly

**Description**

Eye-bolt M14

**Weight**

193 g

**Article-No.**

1.47.96314

Corner pieces

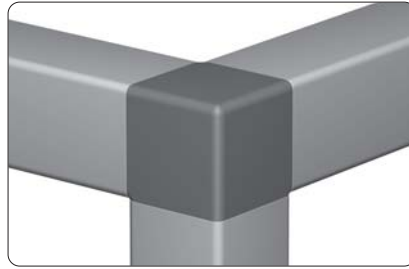

Corner piece set cubic PA: For the connection of three profiles 40x40



Corner piece set 45° PA: For the connection of three profiles 40x40, 2E, 45°, LP

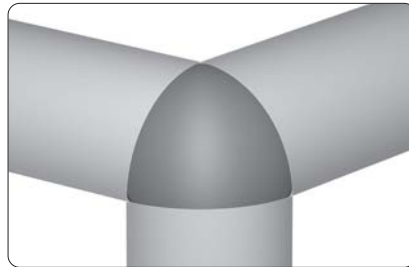

Corner piece set spherical PA: For the connection of three profiles 40x40, soft

**Technical data**

- Cover cap:  
material: PA, black
- Angle:  
material: GD-Zn

**Delivery unit (set)**

- Corner piece angle
- Corner piece cover cap
- Threaded insert M14/M8 (3 pcs)
- Cap head screw (3 pcs)

Cubic

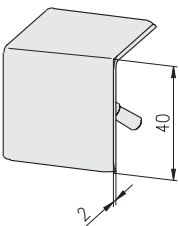
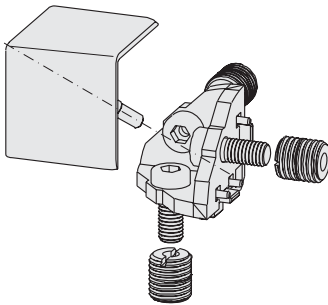

Description	Weight	Article-No.
Corner piece set cubic PA	136.0 g	1.48.14410

Description	Weight	Article-No.
Corner piece cover cap, cubic PA	15.5 g	1.48.14412

45°

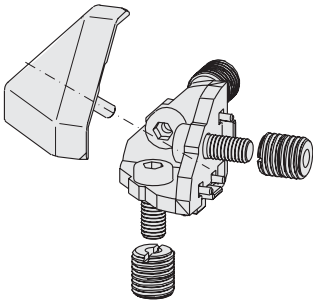

16 20 30 40 45 50 60

Description	Weight	Article-No.
Corner piece set 45° PA	128.0 g	1.48.14440

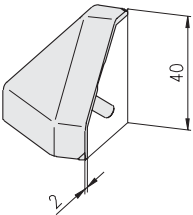

Description	Weight	Article-No.
Corner piece cover cap, 45° PA	7.5 g	1.48.14442

Spherical

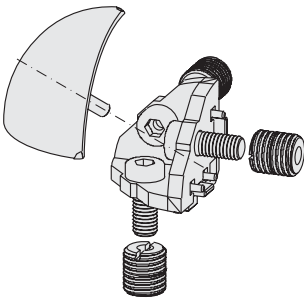

16 20 30 40 45 50 60

Description	Weight	Article-No.
Corner piece set spherical PA	129.0 g	1.48.14480

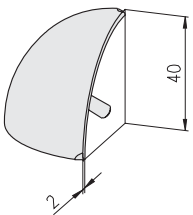

Description	Weight	Article-No.
Corner piece cover cap, spherical PA	8.5 g	1.48.14482

Corner pieces



Corner pieces cubic:  
Corner piece for the connection of 3 square profiles



Corner pieces segment:  
Corner piece for the connection of 2 square profiles and 1 soft profile



Corner pieces segment, 2gang:  
Corner piece for the connection of 2 soft profiles and 1 square profile

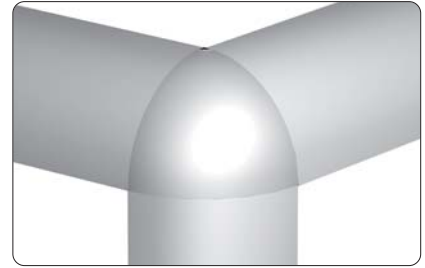

Corner pieces sphere:  
Corner piece for the connection of 3 soft profiles

**Technical data**

- material: aluminium  
 strength: F22  
 surface:
- design anodised: neutral anodised
  - design black: black powder-coated

**General**

The attractive corner pieces are made of solid aluminium and guarantee the entire connection stability

Connection with corner pieces

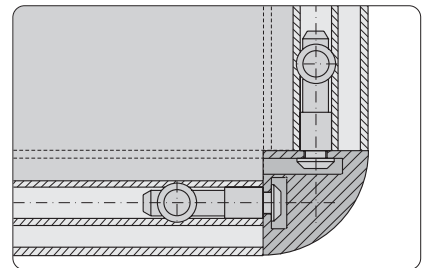

Connection of profiles with one corner piece using the standard connector

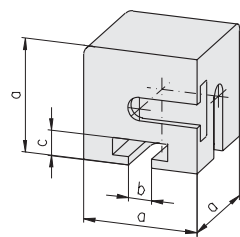
**Corner pieces cubic**

16 20 30 40 45 50 60

Description	a	Slot	b	c	Weight	Article-No.
Corner piece cubic 20, anodised	20	H	6.2	4.6	17 g	1.48.221
Corner piece cubic 30, anodised	30	F	8.2	6.2	59 g	1.48.331
Corner piece cubic 40, anodised	40	E3	8.2	9.0	135 g	1.48.441
Corner piece cubic 50, anodised	50	E4	8.2	10.0	292 g	1.48.551
Corner piece cubic 20, black	20	H	6.2	4.6	17 g	1.48.221.2
Corner piece cubic 30, black	30	F	8.2	6.2	59 g	1.48.331.2
Corner piece cubic 40, black	40	E3	8.2	9.0	135 g	1.48.441.2
Corner piece cubic 50, black	50	E4	8.2	10.0	292 g	1.48.551.2

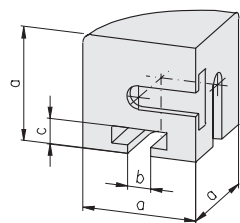
**Corner pieces segment**

16 20 30 40 45 50 60

Description	a	Slot	b	c	Weight	Article-No.
Corner piece segment 20, anodised	20	H	6.2	4.6	12 g	1.48.222
Corner piece segment 30, anodised	30	F	8.2	6.2	43 g	1.48.332
Corner piece segment 40, anodised	40	E3	8.2	9.0	100 g	1.48.442
Corner piece segment 50, anodised	50	E4	8.2	10.0	222 g	1.48.552
Corner piece segment 20, black	20	H	6.2	4.6	12 g	1.48.222.2
Corner piece segment 30, black	30	F	8.2	6.2	43 g	1.48.332.2
Corner piece segment 40, black	40	E3	8.2	9.0	100 g	1.48.442.2
Corner piece segment 50, black	50	E4	8.2	10.0	222 g	1.48.552.2

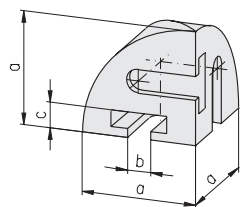
**Corner pieces segment, 2gang**

16 20 30 40 45 50 60

Description	a	Slot	b	c	Weight	Article-No.
Corner piece segment, 2gang 20, anodised	20	H	6.2	4.6	7 g	1.48.223
Corner piece segment, 2gang 30, anodised	30	F	8.2	6.2	24 g	1.48.333
Corner piece segment, 2gang 40, anodised	40	E3	8.2	9.0	57 g	1.48.443
Corner piece segment, 2gang 50, anodised	50	E4	8.2	10.0	135 g	1.48.553
Corner piece segment, 2gang 20, black	20	H	6.2	4.6	7 g	1.48.223.2
Corner piece segment, 2gang 30, black	30	F	8.2	6.2	24 g	1.48.333.2
Corner piece segment, 2gang 40, black	40	E3	8.2	9.0	57 g	1.48.443.2
Corner piece segment, 2gang 50, black	50	E4	8.2	10.0	135 g	1.48.553.2

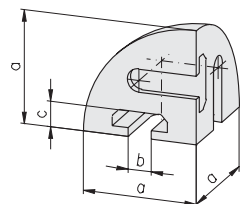

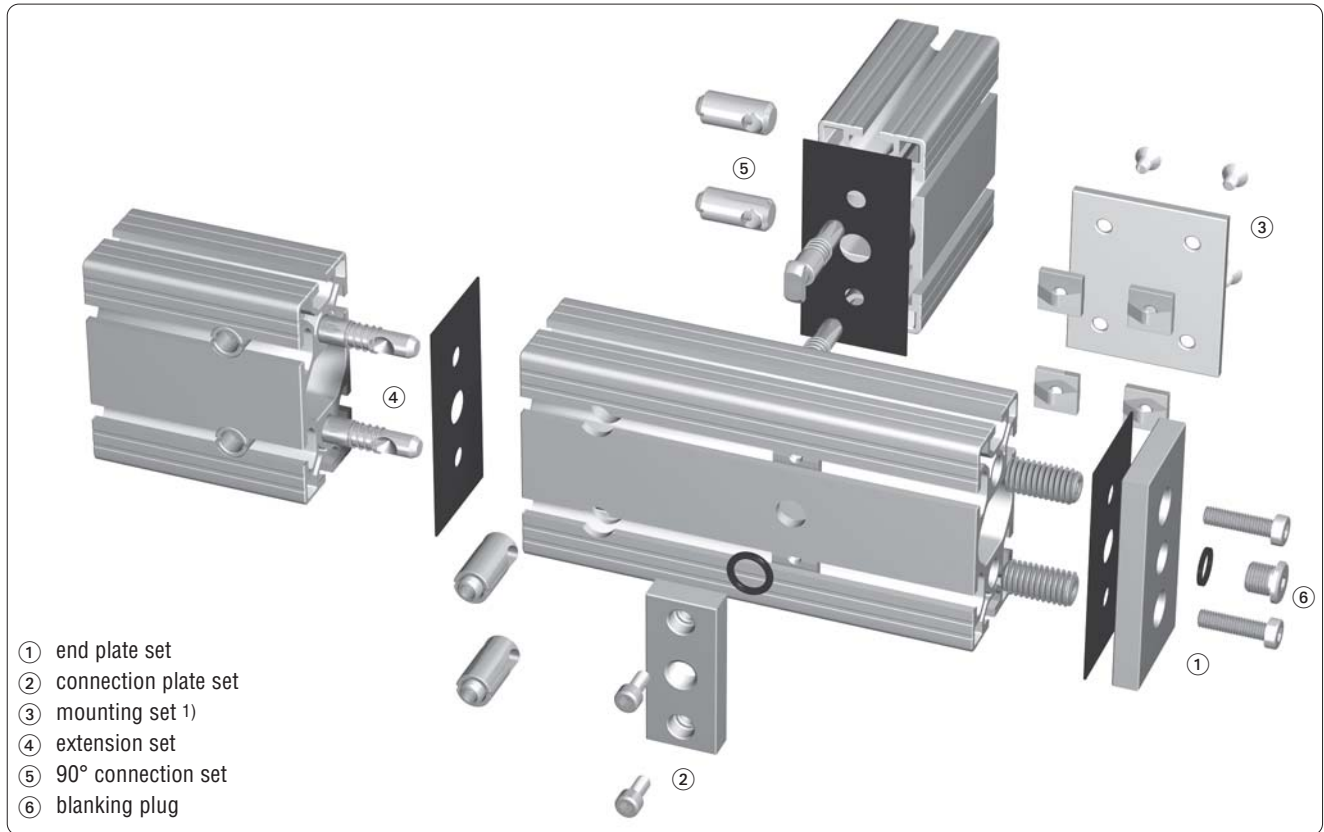

**Corner pieces sphere**

16 20 30 40 45 50 60

Description	a	Slot	b	c	Weight	Article-No.
Corner piece sphere 20, anodised	20	H	6.2	4.6	7 g	1.48.228
Corner piece sphere 30, anodised	30	F	8.2	6.2	24 g	1.48.338
Corner piece sphere 40, anodised	40	E3	8.2	9.0	57 g	1.48.448
Corner piece sphere 50, anodised	50	E4	8.2	10.0	135 g	1.48.558
Corner piece sphere 20, black	20	H	6.2	4.6	7 g	1.48.228.2
Corner piece sphere 30, black	30	F	8.2	6.2	24 g	1.48.338.2
Corner piece sphere 40, black	40	E3	8.2	9.0	57 g	1.48.448.2
Corner piece sphere 50, black	50	E4	8.2	10.0	135 g	1.48.558.2

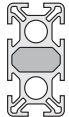

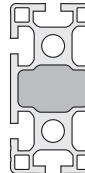
1) for mounting set ⇔ connection plate 1.47.50...

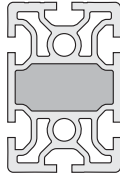
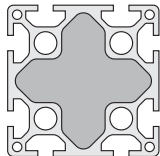
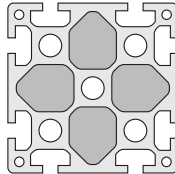
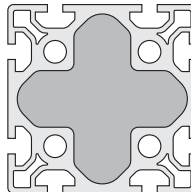
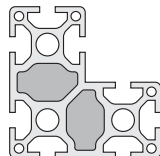
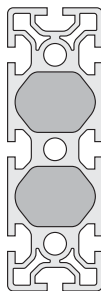
Profiles for pneumatic applications				
PG 30	PG 40	PG 45	PG 50	PG 60
 Profile 30×60, 6F (pneumatic) cross-sectional area: 1) 299.8 mm <sup>2</sup>	 Profile 40×80, 6E 1) 521.8 mm <sup>2</sup>	 Profile 45×90, 6E 1) 816.2 mm <sup>2</sup>	 Profile 50×100, 6E 1) 1,043.3 mm <sup>2</sup>	 Profile 60×90, 6E 1) 1,203.0 mm <sup>2</sup>
	 Profile 80×80, 8E 1) 2,454.1 mm <sup>2</sup>	 Profile 90×90, 8E 1) 635.2 mm <sup>2</sup> (4×)	 Profile 100×100, 8E 1) 4,080.4 mm <sup>2</sup>	<div style="border: 1px solid black; padding: 5px;"> <p><b>Comments</b>                              Any profile with closed interior chambers can also be used as pressure line</p> <p>max. pressure: 10 bar</p> </div>
	 Profile 80×80, 8E, angle 1) 505.7 mm <sup>2</sup> (2×)		 Profile 50×150, 8E 1) 1,115.8 mm <sup>2</sup> (2×)	



**Pneumatic end plates**

**Application**

- for the closing of profile ends
- vent disconnection thread

**Comments**

Blanking plug and reducing nipple

➔ *Pneumatic accessories 1.59*  
Article-No. 1.59.010□□ and  
1.59.020□□

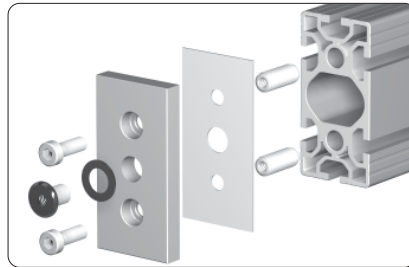
**Technical data**

End plate

- material: aluminium
- strength: F22
- surface: black powder-coated

Seal

- material: NBR

**Comments**

Counterbore DIN 74 - M6 / M8  
cap-screw DIN 912 - M6 / M8

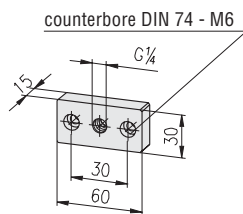
**30×60**

**Description**

Pneumatic end plate set 30×60

**Weight**

110 g

**Article-No.**

1.51.13060

**Single parts**
**Pcs.**

Pneumatic end plate 30×60	1	53 g	1.51.13061
Pneumatic seal 30×60	1	3 g	1.51.13062
Threaded insert M14/M6	2	22 g	1.35.1140615
Cap-screw DIN 912 - M6×16	2	5 g	0.63.D00912.06016

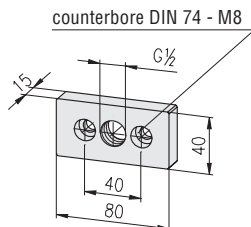
**40×80**

**Description**

Pneumatic end plate set 40×80

**Weight**

153 g

**Article-No.**

1.51.14080

**Single parts**
**Pcs.**

Pneumatic end plate 40×80	1	94 g	1.51.14081
Pneumatic seal 40×80	1	5 g	1.51.14082
Threaded insert M14/M8	2	18 g	1.35.1140815
Cap-screw DIN 912 - M8×16	2	9 g	0.63.D00912.08016

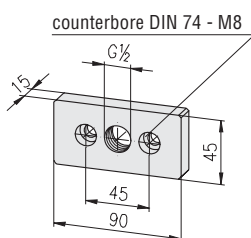
**45×90**

**Description**

Pneumatic end plate set 45×90

**Weight**

179 g

**Article-No.**

1.51.14590

**Single parts**
**Pcs.**

Pneumatic end plate 45×90	1	119 g	1.51.14591
Pneumatic seal 45×90	1	6 g	1.51.14592
Threaded insert M14/M8	2	18 g	1.35.1140815
Cap-screw DIN 912 - M8×16	2	9 g	0.63.D00912.08016

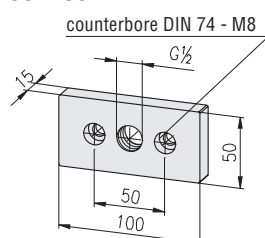
**50×100**

**Description**

Pneumatic end plate set 50×100

**Weight**

206 g

**Article-No.**

1.51.15100

**Single parts**
**Pcs.**

Pneumatic end plate 50×100	1	145 g	1.51.15101
Pneumatic seal 50×100	1	7 g	1.51.15102
Threaded insert M14/M8	2	18 g	1.35.1140815
Cap-screw DIN 912 - M8×16	2	9 g	0.63.D00912.08016

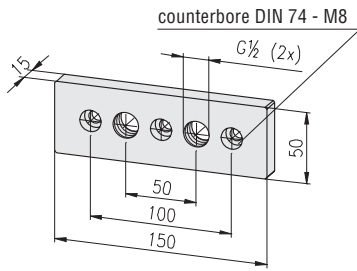
**50x150**

Description	Weight	Article-No.
Pneumatic end plate set 50x150	322 g	1.51.15150

**Single parts**

	Pcs.		
Pneumatic end plate 50x150	1	231 g	1.51.15151
Pneumatic seal 50x150	1	10 g	1.51.15152
Threaded insert M14/M8	3	18 g	1.35.1140815
Cap-screw DIN 912 - M8x16	3	9 g	0.63.D00912.08016

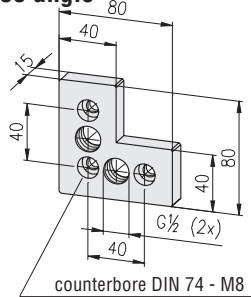
**80x80 angle**

Description	Weight	Article-No.
Pneumatic end plate set 80x80 W	271 g	1.51.18080W

**Single parts**

	Pcs.		
Pneumatic end plate 80x80 W	1	182 g	1.51.18081W
Pneumatic seal 80x80 W	1	8 g	1.51.18082W
Threaded insert M14/M8	3	18 g	1.35.1140815
Cap-screw DIN 912 - M8x16	3	9 g	0.63.D00912.08016

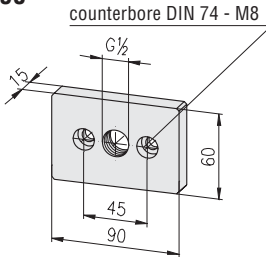
**60x90**

Description	Weight	Article-No.
Pneumatic end plate set 60x90	217 g	1.51.16090

**Single parts**

	Pcs.		
Pneumatic end plate 60x90	1	156 g	1.51.16091
Pneumatic seal 60x90	1	7 g	1.51.16092
Threaded insert M14/M8	2	18 g	1.35.1140815
Cap-screw DIN 912 - M8x16	2	9 g	0.63.D00912.08016

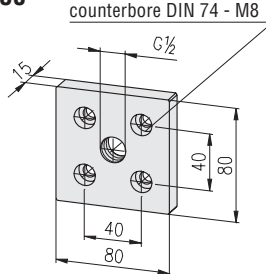
**80x80**

Description	Weight	Article-No.
Pneumatic end plate set 80x80	251 g	1.51.18080

**Single parts**

	Pcs.		
Pneumatic end plate 80x80	1	136 g	1.51.18081
Pneumatic seal 80x80	1	7 g	1.51.18082
Threaded insert M14/M8	4	18 g	1.35.1140815
Cap-screw DIN 912 - M8x16	4	9 g	0.63.D00912.08016

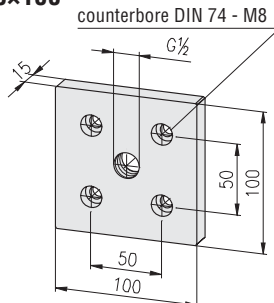
**100x100**

Description	Weight	Article-No.
Pneumatic end plate set 100x100	416 g	1.51.20100

**Single parts**

	Pcs.		
Pneumatic end plate 100x100	1	296 g	1.51.20101
Pneumatic seal 100x100	1	12 g	1.51.20102
Threaded insert M14/M8	4	18 g	1.35.1140815
Cap-screw DIN 912 - M8x16	4	9 g	0.63.D00912.08016

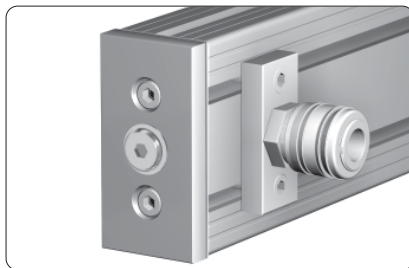
**Pneumatic connection plates**

**Application**

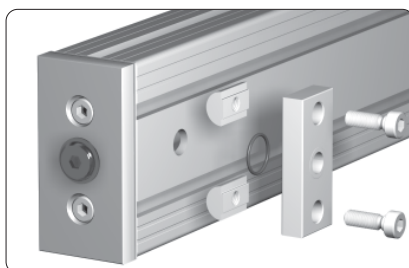
Pneumatic connection for inlet and exhaust of air pressure

**Technical data**
**End plate**

- material: aluminium
- strength: F22
- surface: black powder-coated

**O-Ring**

- material: NBR

**Comments**

Counterbore DIN 74 - M6 / M8 for cap-screw DIN 912 - M6 / M8

**30×60**

counterbore DIN 74 - M6

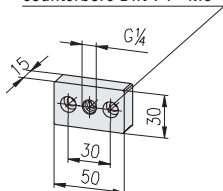
**Description**

Pneumatic connection plate set 30×60

**Weight**

59.2 g

**Article-No.**

1.52.03061

**Single parts**
**Pcs.**

Pneumatic connection plate 30×60	1	40.0 g	1.52.03062
O-Ring 14×3	1	0.6 g	1.59.11403
T-Nut for subs. insertion F, M6	2	4.3 g	1.324.FM6
Cap-screw DIN 912 - M6×12	2	5.0 g	0.63.D00912.06012

**40×80**

counterbore DIN 74 - M6

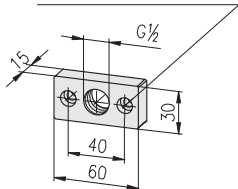
**Description**

Pneumatic connection plate set 40×80

**Weight**

80.6 g

**Article-No.**

1.52.14081

**Single parts**
**Pcs.**

Pneumatic connection plate 40×80	1	50.0 g	1.52.14082
O-Ring 20×3	1	0.6 g	1.59.12003
T-Nut for subs. insertion E, M6	2	10.0 g	1.324.EM6
Cap-screw DIN 912 - M6×16	2	5.0 g	0.63.D00912.06016

**45×90**

counterbore DIN 74 - M6

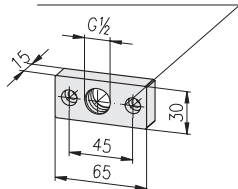
**Description**

Pneumatic connection plate set 45×90

**Weight**

84.6 g

**Article-No.**

1.52.04591

**Single parts**
**Pcs.**

Pneumatic connection plate 45×90	1	5.0 g	1.52.04592
O-Ring 20×3	1	0.6 g	1.59.12003
T-Nut for subs. insertion E, M6	2	10.0 g	1.324.EM6
Cap-screw DIN 912 - M6×16	2	5.0 g	0.63.D00912.06016

**50×100**

counterbore DIN 74 - M6

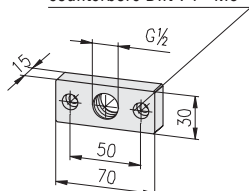
**Description**

Pneumatic connection plate set 50×100

**Weight**

90.6 g

**Article-No.**

1.52.15101

**Single parts**
**Pcs.**

Pneumatic connection plate 50×100	1	60.0 g	1.52.15102
O-Ring 20×3	1	0.6 g	1.59.12003
T-Nut for subs. insertion E, M6	2	10.0 g	1.324.EM6
Cap-screw DIN 912 - M6×16	2	5.0 g	0.63.D00912.06016

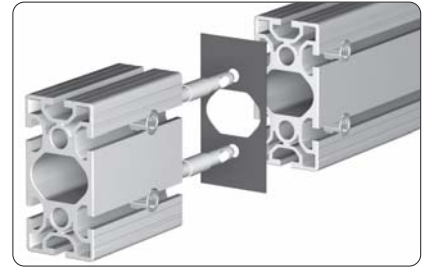
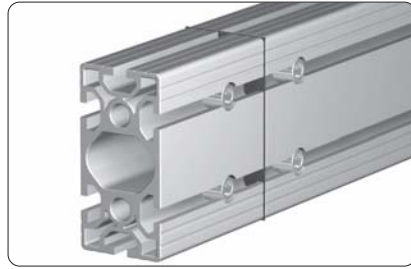
**Pneumatic extension sets**

For the extension of air pressurised profiles

**for profile 30×60**

Description	Pcs.	Weight	Article-No.
Pneumatic extension set 30×60		177 g	1.54.03061
<b>Single parts</b>			
Pneumatic seal 30×60	1	3 g	1.51.13062
Connector, profile extension	2	87 g	1.21.3V0

**for profile 40×80**

Pneumatic extension set 40×80		193 g	1.54.04081
<b>Single parts</b>			
Pneumatic seal 40×80	1	5 g	1.51.14082
Connector, profile extension	2	94 g	1.21.4V0

**for profile 45×90**

Pneumatic extension set 45×90		204 g	1.54.04591
<b>Single parts</b>			
Pneumatic seal 45×90	1	6 g	1.51.14592
Connector, profile extension	2	99 g	1.21.45V0

**for profile 50×100**

Pneumatic extension set 50×100		211 g	1.54.05101
<b>Single parts</b>			
Pneumatic seal 50×100	1	7 g	1.51.15102
Connector, profile extension	2	102 g	1.21.5V0

**for profile 50×150**

Pneumatic extension set 50×150		316 g	1.54.05151
<b>Single parts</b>			
Pneumatic seal 50×150	1	10 g	1.51.15152
Connector, profile extension	3	102 g	1.21.5V0

**for profile 60×90**

Pneumatic extension set 60×90		239 g	1.54.06091
<b>Single parts</b>			
Pneumatic seal 60×90	1	7 g	1.51.16092
Connector, profile extension	2	116 g	1.21.6V0

**for profile 80×80 angle**

Pneumatic extension set 80×80 W		289 g	1.54.08081W
<b>Single parts</b>			
Pneumatic seal 80×80 W	1	7 g	1.51.18082W
Connector, profile extension	3	94g	1.21.4V0

**for profile 80×80**

Pneumatic extension set 80×80		384 g	1.54.08081
<b>Single parts</b>			
Pneumatic seal 80×80	1	8 g	1.51.18082
Connector, profile extension	4	94 g	1.21.4V0

**for profile 100×100**

Pneumatic extension set 100×100		420 g	1.54.10101
<b>Single parts</b>			
Pneumatic seal 100×100	1	12 g	1.51.20102
Connector, profile extension	4	102 g	1.21.5V0

Pneumatic 90° connection sets

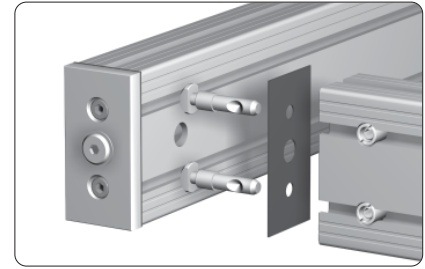
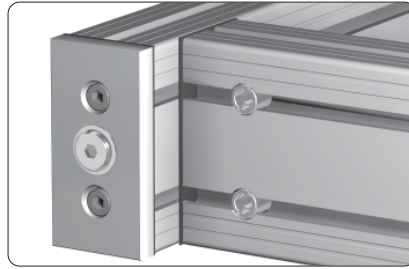

For 90° connections of air pressurised profiles

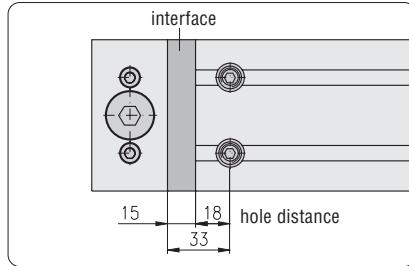

For the connection of profile 80×80, 100×100 a pneumatic connecting plate must be inserted to seal the chamber inside

for profile 30×60

Description	Pcs.	Weight	Article-No.
Pneumatic 90° connection set 30×60		99 g	1.55.03061
<b>Single parts</b>			
Pneumatic seal 30×60	1	3 g	1.51.13062
Connector, standard 90°	2	48 g	1.21.3F2

for profile 40×80

Pneumatic 90° connection set 40×80		115 g	1.55.04081
<b>Single parts</b>			
Pneumatic seal 40×80	1	5 g	1.51.14082
Connector, standard 90°	2	55 g	1.21.4E2

for profile 45×90

Pneumatic 90° connection set 45×90		63 g	1.55.04591
<b>Single parts</b>			
Pneumatic seal 45×90	1	6 g	1.51.14592
Connector, standard 90°	2	57 g	1.21.45E2

for profile 50×100

Pneumatic 90° connection set 50×100		125 g	1.55.05101
<b>Single parts</b>			
Pneumatic seal 50×100	1	7 g	1.51.15102
Connector, standard 90°	2	59 g	1.21.5E2

for profile 50×150

Pneumatic 90° connection set 50×150		187 g	1.55.05151
<b>Single parts</b>			
Pneumatic seal 50×150	1	10 g	1.51.15152
Connector, standard 90°	3	59 g	1.21.5E2

for profile 60×90

Pneumatic 90° connection set 60×90		70 g	1.55.06091
<b>Single parts</b>			
Pneumatic seal 60×90	1	7 g	1.51.16092
Connector, standard 90°	2	63 g	1.21.6E2

for profile 80×80

Pneumatic 90° connection set 80×80		446 g	1.55.08081
<b>Single parts</b>			
Pneumatic seal 80×80	1	8 g	1.51.18082
Connector, standard 90°	4	55 g	1.21.4E2
Pneumatic connecting plate	1	217 g	1.55.08084
O-Ring 20×3	1	0.6 g	1.59.12003

## for profile 100×100

Pneumatic 90° connection set 100×100		618 g	1.55.10101
<b>Single parts</b>			
Pneumatic seal 100×100	1	12 g	1.51.20102
Connector, standard 90°	4	55 g	1.21.5E2
Pneumatic connecting plate	1	369 g	1.55.10104
O-Ring 20×3	1	0.6 g	1.59.12003

## Pneumatic accessories

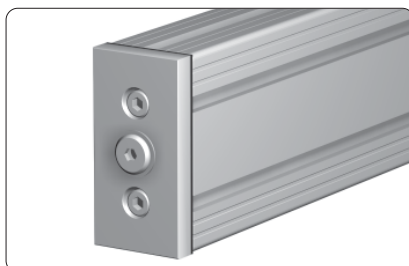
**Application**

Blanking plug for the connection thread

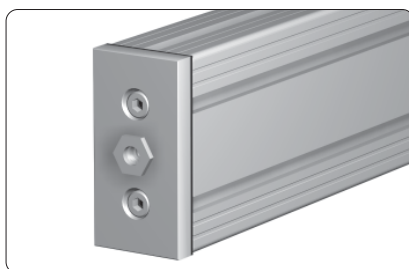
**Application**

Reducing nipple to reduce the connection thread

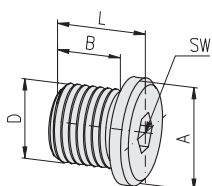
**Blanking plug**

**Technical data**

material:

- blanking plug: steel, galvanised
- sealing: NBR

**Comments**

Including sealing

Description	D	A	B	L	SW	Weight	Article-No.
Blanking plug,	B-1/4"	18	12	15	6	15 g	1.59.01030
Blanking plug,	B-1/2"	26	14	18	10	43 g	1.59.01050

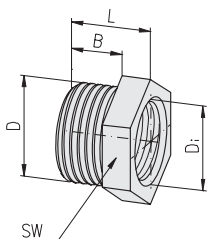
**Reducing nipple**

**Technical data**

material: brass

Description	Di	D	B	L	SW	Weight	Article-No.
Reducing nipple,	1/4" i - 3/8" a		9	14	19	14 g	1.59.02040
Reducing nipple,	3/8" i - 1/2" a		10	14	22	25 g	1.59.02050

**Sealing ring**

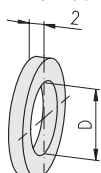
for reducing nipple

**Technical data**

material: PA, white

Description	D	Weight	Article-No.
Sealing ring	Ø1/4"	1 g	1.59.03030
Sealing ring	Ø3/8"	1 g	1.59.03040
Sealing ring	Ø1/2"	2 g	1.59.03050

**Handles light PA**



**Application**

For doors and drawers of light material

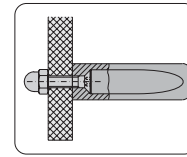

Mounting on panel elements

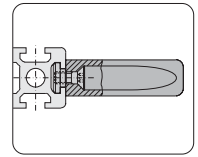

Mounting on profiles

**Technical data**

material: PA

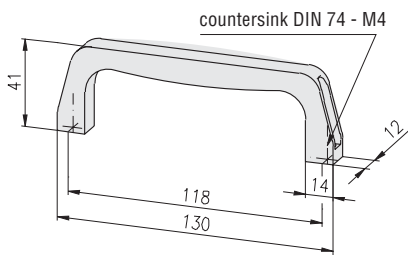

Description	Colour	Weight	Article-No.
Handle light PA	grey	30 g	1.61.20.1
Handle light PA	black	30 g	1.61.20.2

**Handle light Alu**



**Application**

For doors and drawers of light material

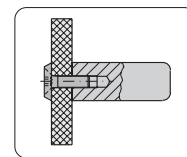

Mounting on panel elements

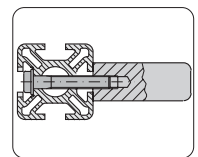

Mounting on profiles

**Technical data**

material: aluminium  
surface: neutral anodised

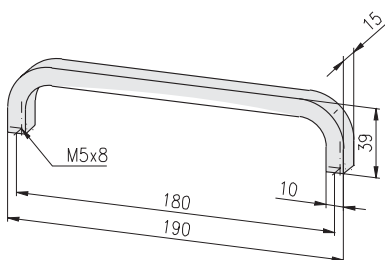

Description	Weight	Article-No.
Handle light Alu	85 g	1.61.210

**Handle PA**

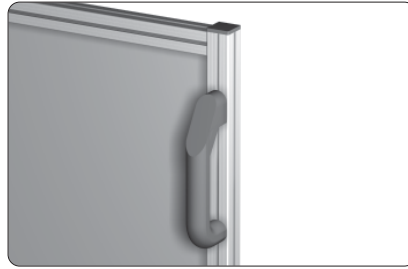

**Application**

Ergonomical designed handle

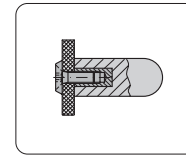

Mounting on panel elements

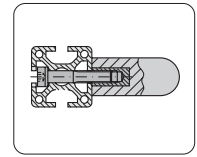

Mounting on profiles

**Technical data**

material: PA  
colour: black

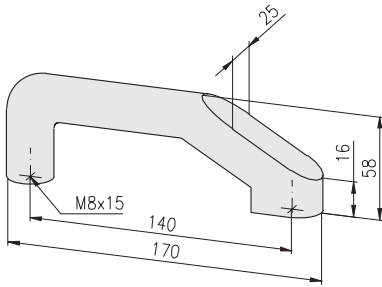

**Description**

Handle PA, with thread M8

**Weight**

166 g

**Article-No.**

1.61.230

**Handles PA**

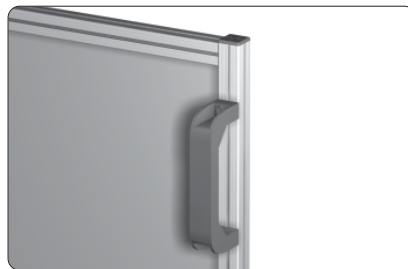

**Application**

Handle with fixing possibilities from the front and the rear

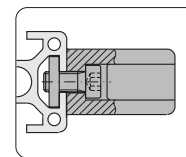

Handle with bore

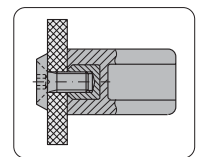

Handle with thread

**Technical data**

material: PA  
colour: black

**with bore**

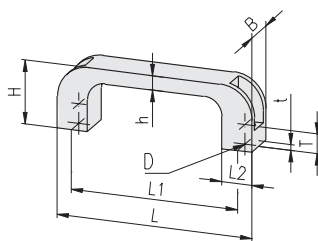

**Description**

Description	D	L	Weight	Article-No.
Handle PA, with bore	Ø6.5	110	24 g	1.61.24110
Handle PA, with bore	Ø6.5	139	44 g	1.61.24139
Handle PA, with bore	Ø8.5	151	64 g	1.61.24151
Handle PA, with bore	Ø8.5	200	74 g	1.61.24200
Handle PA, with bore	Ø10.5	260	114 g	1.61.24260

**with thread**

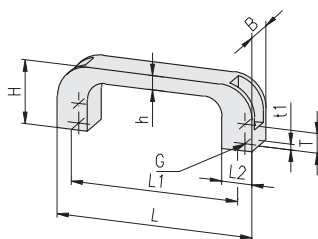

**Description**

Description	G	L	Weight	Article-No.
Handle PA, with thread	M6	110	30 g	1.61.25110
Handle PA, with thread	M6	139	50 g	1.61.25139
Handle PA, with thread	M8	151	70 g	1.61.25151
Handle PA, with thread	M8	200	88 g	1.61.25200
Handle PA, with thread	M10	260	125 g	1.61.25260

L	L1	L2	H	h	T	t	t1	B
110	94	17	37	8	13	6	10	21
139	120	20	40	10	15	6	10	24
151	132	22	43	10	16	6	15	26
200	180	25	50	11	20	9	15	28
260	235	28	53	12	21	11	15	32



### Handle system round design



#### Application

Handle system for making handles of any length

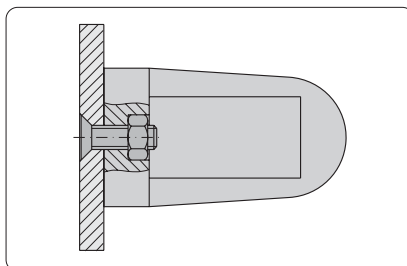

Mounting on panel elements

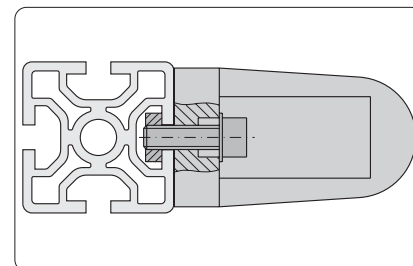

Mounting on profiles

### Corner piece PA-GF

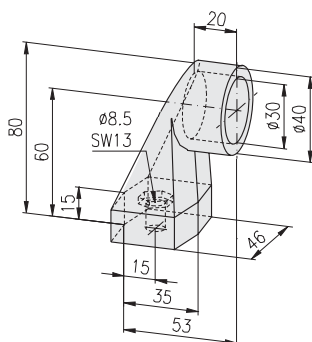

#### Technical data

material: PA-GF  
colour: black

#### Description

Corner piece PA-GF

#### Weight

76 g

#### Article-No.

1.61.280

### Centre piece PA-GF

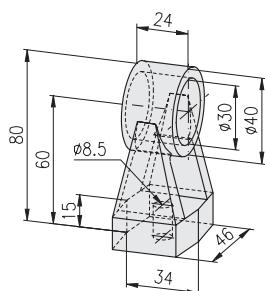

#### Technical data

material: PA-GF  
colour: black

#### Description

Centre piece PA-GF

#### Weight

53 g

#### Article-No.

1.61.281

### Tube Ø30x3

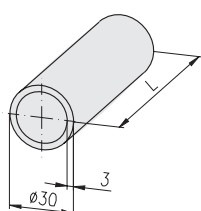

#### Technical data

material: aluminium  
surface: neutral anodised  
tube length: 6 m

#### Description

Tube Ø30x3

bar

**Weight**  
4.2 kg

#### Article-No.

1.19.16130.60



Tube Ø30x3

cut to length

0.7 kg/m

1.19.16130-A00A00/...

/... = length in mm

**Handle system  
oval design**



**Application**

Handle system for making handles of any length

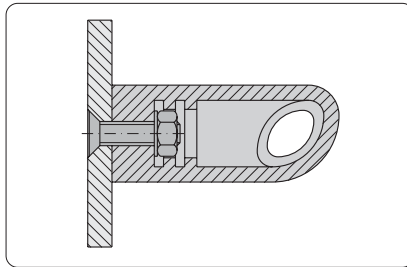

Mounting on panel elements

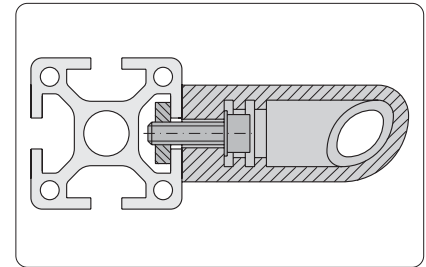

Mounting on profiles

**Oval corner piece right**

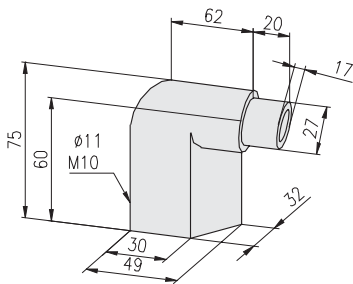

**Technical data**

material: PA-GF  
colour: black

**Description**

Oval corner piece right

**Weight**

65 g

**Article-No.**

1.61.290

**Oval corner piece left**

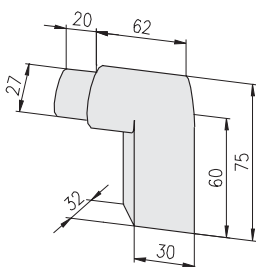

**Technical data**

material: PA-GF  
colour: black

**Description**

Oval corner piece left

**Weight**

65 g

**Article-No.**

1.61.291

**Oval tube 35x4**

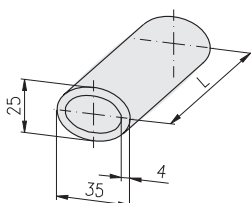

**Technical data**

material: aluminium  
surface: neutral anodised  
tube length: 3 m

**Description**

Oval tube 35x4

bar

**Weight**

2.5 kg

**Article-No.**

1.61.292.30



Oval tube 35x4

cut to length

0.83 kg/m

1.61.292-A00A00/...

/... = length in mm

**Grab handles**



**Application**

Alu grip handles for customer's assembly from standard profiles

**Comments**

Grab handles increase the rigidity of panels without profile frames

**Profile 20x30, 1F, LP**

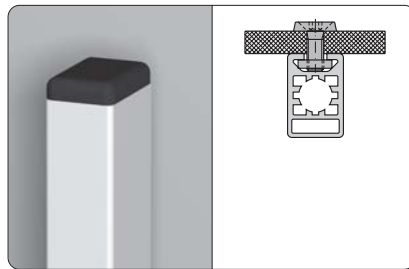
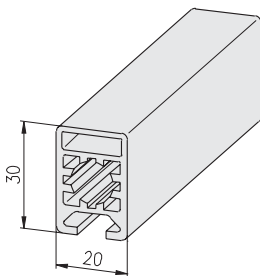

Fixing of the profile directly on the panel element

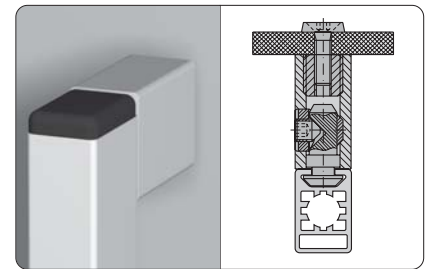

Fixing of the profile with a connecting piece on the panel element

**Description**

Profile 20x30, 1F, LP	cut to length	0.66 kg/m	1.11.020030.14LP-A00A00/...
-----------------------	---------------	-----------	-----------------------------

/... = length in mm

**Weight**

**Article-No.**

**Grab handle profiles**

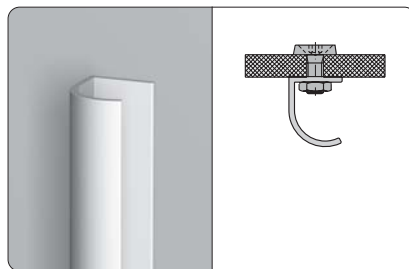
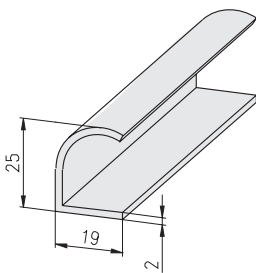

**Description**

Grab handle profile	cut to length	0.3 kg/m	1.19.14319-A00A00/...
---------------------	---------------	----------	-----------------------

/... = length in mm

**Weight**

**Article-No.**

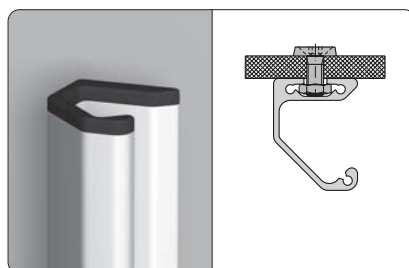
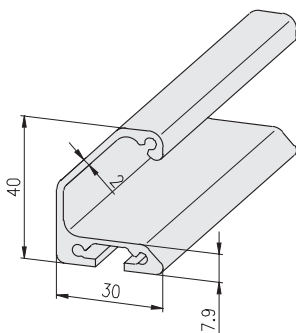

**Description**

Grab handle profile	cut to length	0.73 kg/m	1.19.14330-A00A00/...
---------------------	---------------	-----------	-----------------------

/... = length in mm

**Weight**

**Article-No.**

**Technical data**

material: PA-GF  
colour: black

**Description**

Cover cap kit left/right for grab handle profile		3.6 g	1.19.14330A
--	--	-------	-------------

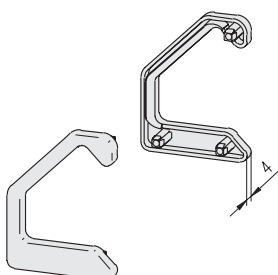

**Hinges**



**Application**

Hinge for doors and flaps of light material

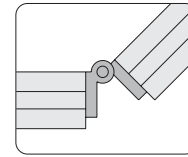

Face-sided connection of 2 profiles

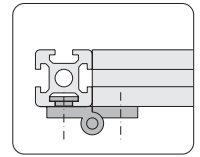

Connection of 2 profiles in rectangular position

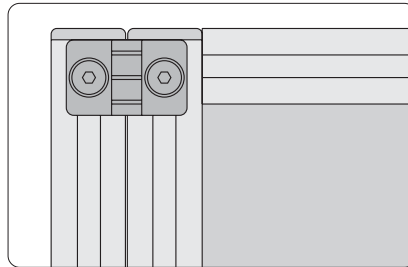

Doors with profile frames

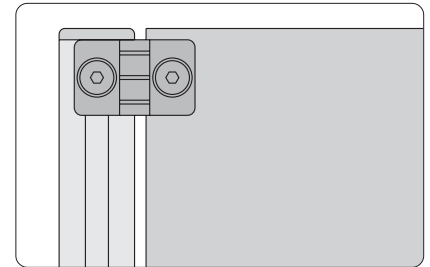

Doors made of panel elements without profile frames

Technical data			
Hinge	20x32	30x39	40x40
material:	PA-GF	PA-GF	GD-Zn, coated
colour:	black		
max. static load:	50 N	100 N	150 N

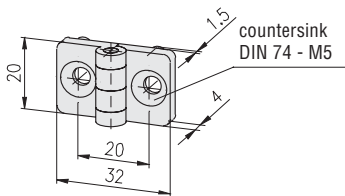

- 16
- 20
- 30
- 40
- 45
- 50
- 60

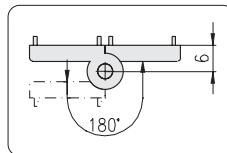

Swivel angle

**Comments**

Countersink DIN 74 - M5 for countersunk screw DIN 7991 - M5

Description	Weight	Article-No.
Hinge 20x32	6 g	1.62.12032

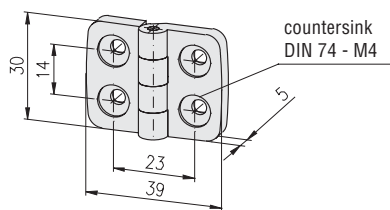

- 16
- 20
- 30
- 40
- 45
- 50
- 60

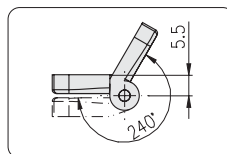

Swivel angle

**Comments**

Countersink DIN 74 - M4 for countersunk screw DIN 7991 - M4

Description	Weight	Article-No.
Hinge 30x39	7.6 g	1.62.23039

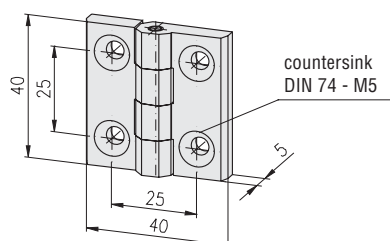

- 16
- 20
- 30
- 40
- 45
- 50
- 60

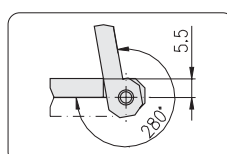

Swivel angle

**Comments**

Countersink DIN 74 - M5 for countersunk screw DIN 7991 - M5

Description	Weight	Article-No.
Hinge 40x40	55 g	1.62.24040

**Lift-off hinges**



**Application**

Enables the connection of different profile widths in parallel as well as in rectangular arrangement

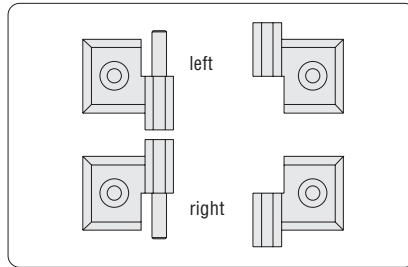

Non-liftable door with one right- and one left-sided hinge

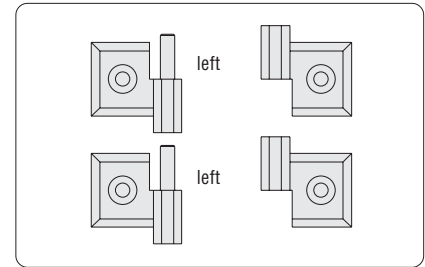

Liftable door with two similar hinges

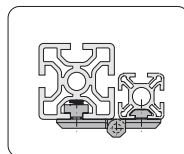

1 profile 30x30  
1 profile 50x50

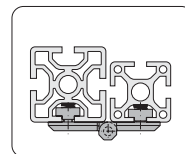

1 profile 40x40  
1 profile 50x50

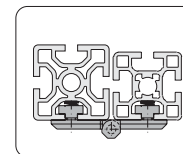

1 profile 45x45  
1 profile 50x50

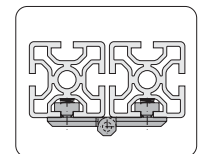

2 profiles 50x50

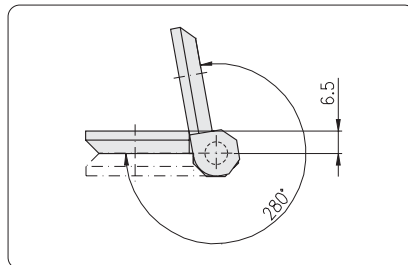

Swivel angle

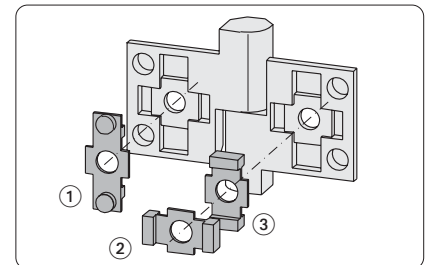

Application of locking device:

- ① for panel element
- ② for profile slot, horizontal
- ③ for profile slot, vertical

**Technical data**

material: GD-Zn  
 surface: black coated  
 hinge bolt: stainless steel  
 max. static load: 250 N

**Comments**

Countersink DIN 74 - M6 for  
 countersunk screw DIN 7991 - M6

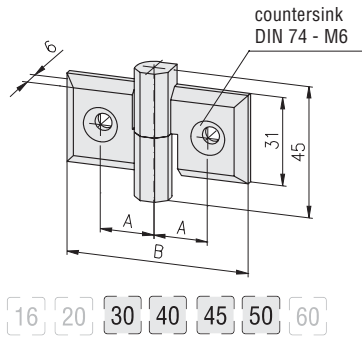

Description	A	B	Weight	Article-No.
Hinge 31,	A16.5 left	59	68 g	1.62.331.16/16L
Hinge 31,	A19.0 left	64	72 g	1.62.331.19/19L
Hinge 31,	A21.5 left	69	76 g	1.62.331.21/21L
Hinge 31,	A24.0 left	74	81 g	1.62.331.24/24L
Hinge 31,	A26.5 left	79	86 g	1.62.331.26/26L

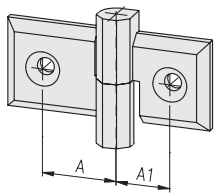

**Combinations**

Description	A <sup>1)</sup>	A1 <sup>1)</sup>	Article-No.
Hinge 31 × □□/□□	left		1.62.331.□□/□□L

<sup>1)</sup> Data without decimal places

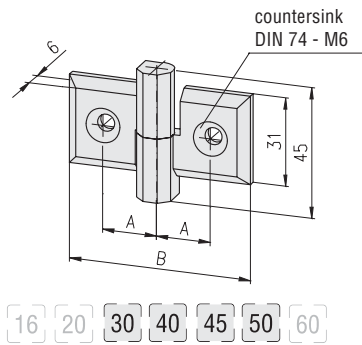

Description	A	B	Weight	Article-No.
Hinge 31,	A16.5 right	59	68 g	1.62.331.16/16R
Hinge 31,	A19.0 right	64	72 g	1.62.331.19/19R
Hinge 31,	A21.5 right	69	76 g	1.62.331.21/21R
Hinge 31,	A24.0 right	74	81 g	1.62.331.24/24R
Hinge 31,	A26.5 right	79	86 g	1.62.331.26/26R

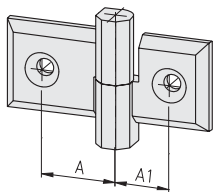

**Combinations**

Description	A <sup>1)</sup>	A1 <sup>1)</sup>	Article-No.
Hinge 31 × □□/□□	right		1.62.331.□□/□□R

<sup>1)</sup> Data without decimal places

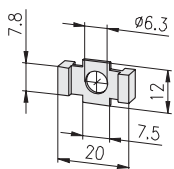

**Technical data**

material: GD-Zn  
surface: rough

Description	Weight	Article-No.
Anti-twist device for slot 8 mm	4 g	1.62.331x1

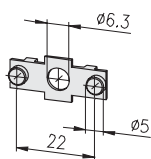

**Technical data**

material: GD-Zn  
surface: rough

Description	Weight	Article-No.
Anti-twist device for panel element	4 g	1.62.331x2

**Lift-off hinges**



**Application**

The hinges enable the connection of profiles with different widths

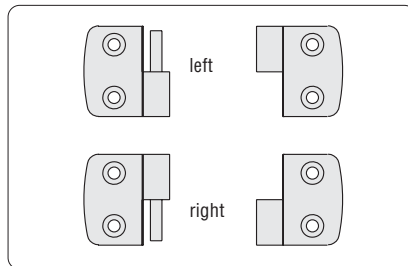

Non-liftable door with one right- and one left-sided hinge

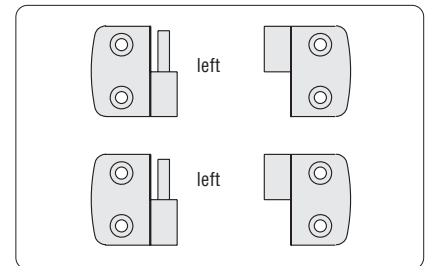

Liftable door with two similar hinges

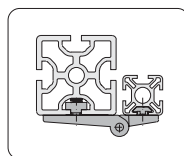

1 profile 60x60  
1 profile 30x30

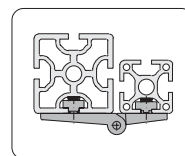

1 profile 60x60  
1 profile 40x40

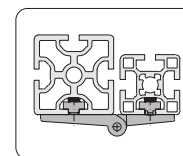

1 profile 60x60  
1 profile 45x45

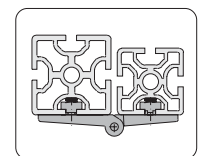

1 profile 60x60  
1 profile 50x50

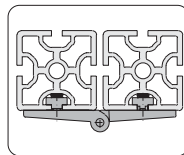

2 profiles 60x60

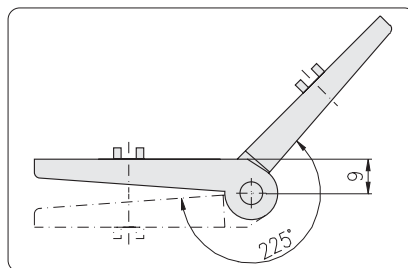

Swivel angle

**Technical data**

material: PA-GF  
 surface: black  
 hinge bolt: stainless steel  
 max. static load: 150 N

**Comments**

Countersink DIN 74 - M6 for  
 countersunk screw DIN 7991 - M6

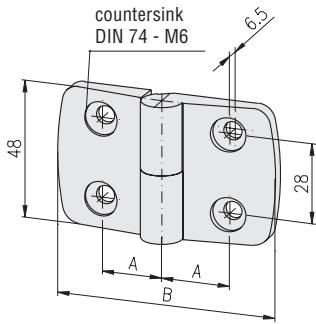

16 20 30 40 45 50 60

Description	A	B	Weight	Article-No.
Lift-off hinge 48	A17.5, left	59	8 g	1.62.348.17/17L
Lift-off hinge 48	A22.5, left	77	10 g	1.62.348.22/22L
Lift-off hinge 48	A25.0, left	87	15 g	1.62.348.25/25L
Lift-off hinge 48	A27.5, left	97	25 g	1.62.348.27/27L
Lift-off hinge 48	A32.5, left	115	35 g	1.62.348.32/32L

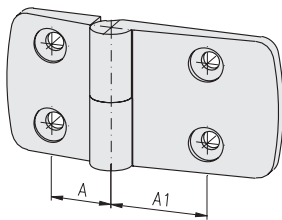

**Combinations**

Description	A <sup>1)</sup> A1 <sup>1)</sup>	Article-No.
Lift-off hinge 48 × □□/□□ left		1.62.348.□□/□□L

<sup>1)</sup> Data without decimal places

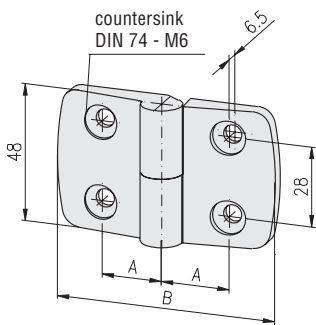

16 20 30 40 45 50 60

Description	A	B	Weight	Article-No.
Lift-off hinge 48	A17.5, right	59	8 g	1.62.348.17/17R
Lift-off hinge 48	A22.5, right	77	10 g	1.62.348.22/22R
Lift-off hinge 48	A25.0, right	87	15 g	1.62.348.25/25R
Lift-off hinge 48	A27.5, right	97	25 g	1.62.348.27/27R
Lift-off hinge 48	A32.5, right	115	35 g	1.62.348.32/32R

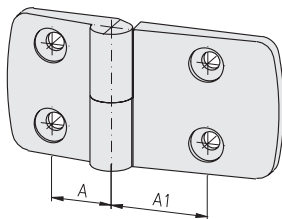

**Combinations**

Description	A <sup>1)</sup> A1 <sup>1)</sup>	Article-No.
Lift-off hinge 48 × □□/□□ right		1.62.348.□□/□□R

<sup>1)</sup> Data without decimal places



**Hinges**



**Application**

Hinge for doors and flaps of light material

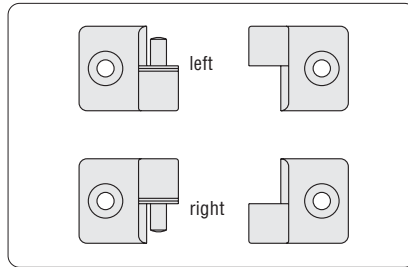

Non-liftable door with one right- and one left-sided hinge

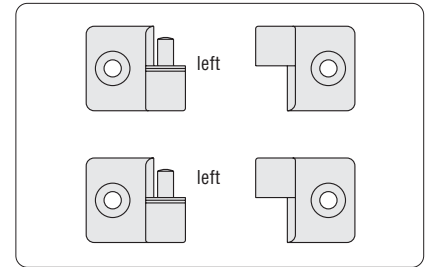

Liftable door with two similar hinges

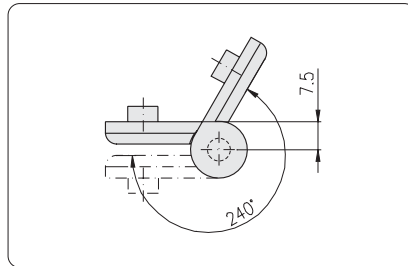

Swivel angle

**Technical data**

material: PA-GF  
 colour: black  
 max. static load: 100 N

**Comments**

Countersink DIN 74 - M6 for countersunk screw DIN 7991 - M6

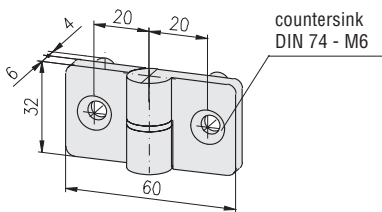

- 16
- 20
- 30
- 40
- 45
- 50
- 60

**Description**

Hinge 32x60 left

**Weight**

21 g

**Article-No.**

1.62.41L

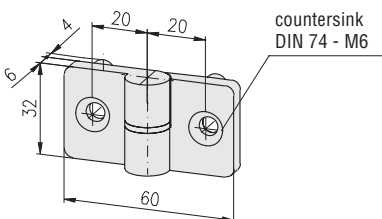

- 16
- 20
- 30
- 40
- 45
- 50
- 60

**Description**

Hinge 32x60 right

**Weight**

21 g

**Article-No.**

1.62.41R

**Double hinge**



**Application**

Hinge for doors and flaps of light material

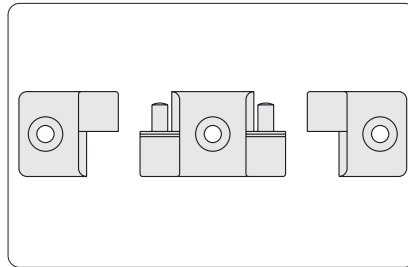

Liftable doors

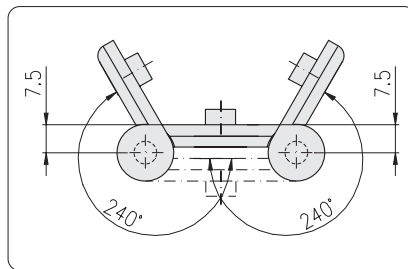

Swivel angle

**Technical data**

material: PA-GF  
max. static load: 100 N

**Comments**

Countersink DIN 74 - M6 for countersunk screw DIN 7991 - M6

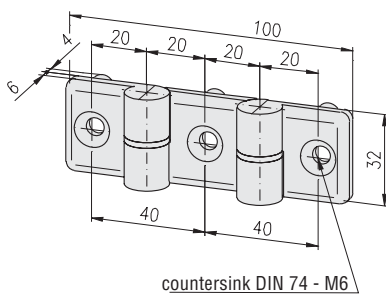

Description	Colour	Weight	Article-No.
Double hinge	grey	40 g	1.62.420.1
Double hinge	black	40 g	1.62.420.2

**Hinges**



**Application**

The hinges enable the connection of profiles with different widths

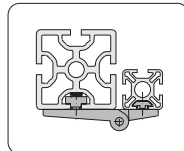

1 profile 60x60  
1 profile 30x30

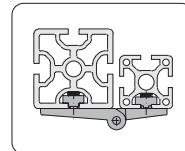

1 profile 60x60  
1 profile 40x40

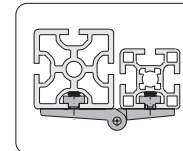

1 profile 60x60  
1 profile 45x45

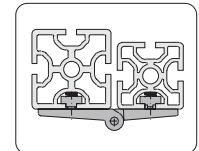

1 profile 60x60  
1 profile 50x50

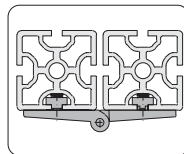

2 profiles 60x60

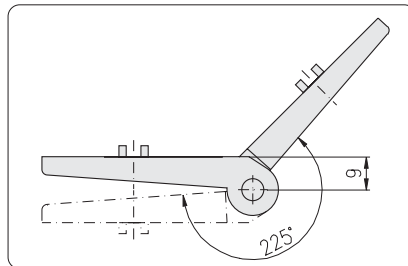

Swivel angle

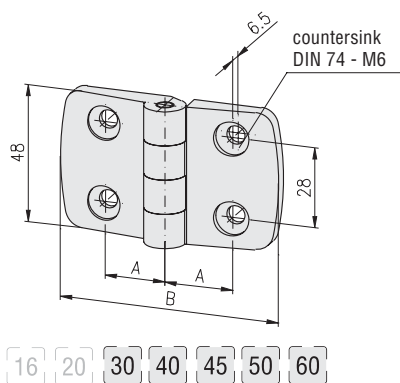

**Technical data**

material: PA-GF  
colour: black  
hinge bolt: stainless steel  
max. static load: 200 N

**Comments**

Countersink DIN 74 - M6 for  
countersunk screw DIN 7991 - M6

Description	A	B	Weight	Article-No.
Hinge 48 fixed	A17.5	59	8 g	1.62.448.17/17
Hinge 48 fixed	A22.5	77	10 g	1.62.448.22/22
Hinge 48 fixed	A25.0	87	15 g	1.62.448.25/25
Hinge 48 fixed	A27.5	97	25 g	1.62.448.27/27
Hinge 48 fixed	A32.5	115	35 g	1.62.448.32/32

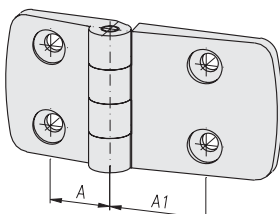

**Combinations**

Description	A <sup>1)</sup>	A1 <sup>1)</sup>	Article-No.
Hinge 48 fixed × □□/□□			1.62.448.□□/□□

<sup>1)</sup> Data without decimal places

**Hinge  
30x60**

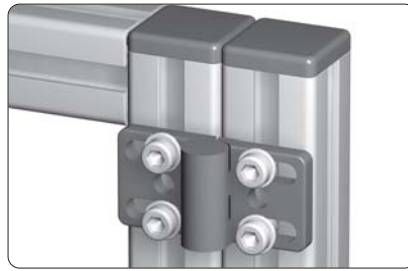

**Application**

Hinge or higher loads such as doors with profile frames

**Technical data**

material: GD-Zn  
 colour: black  
 surface: coated  
 max. static load: 400 N

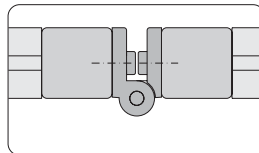

Connection of 2 vertical profiles, all anti-twist safety devices removed

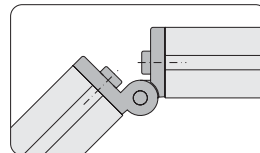

Face-sided connection of 2 profiles, with anti-twist safety device

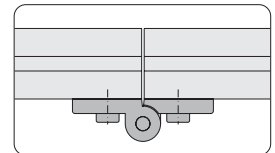

Connection of 2 horizontal profiles, with anti-twist safety device

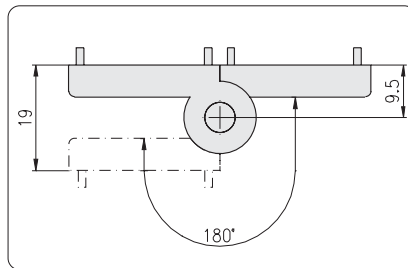
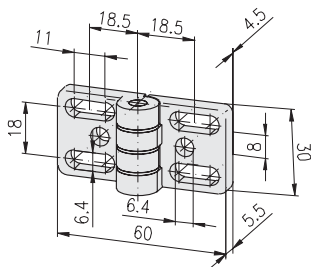

Swivel angle

- 16
- 20
- 30
- 40
- 45
- 50
- 60

**Description**

Hinge 30x60

**Weight**

68.8 g

**Article-No.**

1.62.51030060

**Hinge  
40x80**



**Application**

Hinge or higher loads such as doors with profile frames

**Technical data**

material: GD-Zn  
colour: black  
surface: coated  
max. static load: 750 N

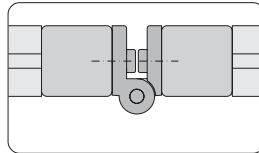

Connection of 2 vertical profiles, all anti-twist safety devices removed

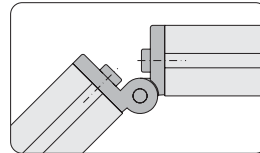

Face-sided connection of 2 profiles, with anti-twist safety device

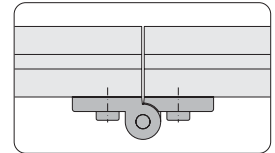

Connection of 2 horizontal profiles, with anti-twist safety device

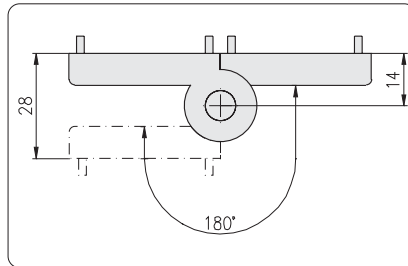
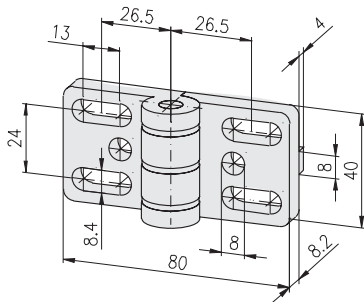

Swivel angle

- 16 20 30 40 45 50 60

**Description**

Hinge 40x80

**Weight**

180 g

**Article-No.**

1.62.520

**Hinges  
40x80**

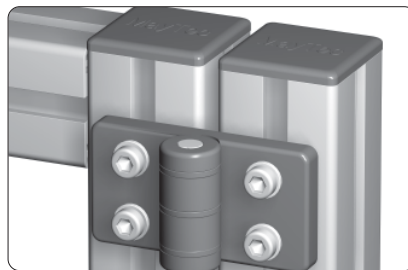

**Application**

Hinge or higher loads such as doors with profile frames

**Technical data**

material: GD-Zn  
colour: black  
surface: powder-coated  
max. static load: 750 N

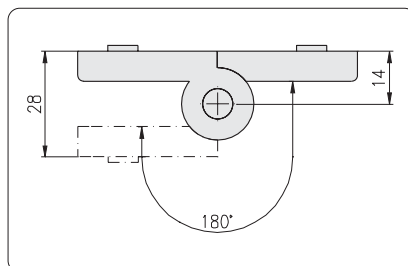

Swivel angle

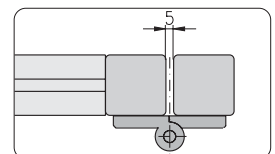

Connection of 2 vertical profiles

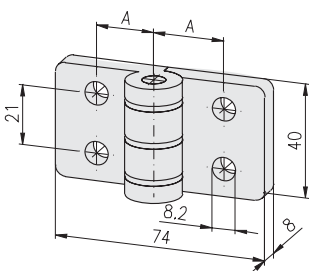

**Fastening elements:**

PG 40: T-Nut for subs. insertion E, M8 1.324.EM8  
PG 45: T-Nut E, M8 1.32.EM8  
PG 40/45: Threaded plate E, M8 1.31.EM8

- 16 20 30 40 45 50 60

**Description**

Hinge 40x80 for PG 40

**A**

22.5

**Weight**

194 g

**Article-No.**

1.62.53045

Hinge 40x80 for PG 45

25.0

194 g

1.62.53050

**Hinges**

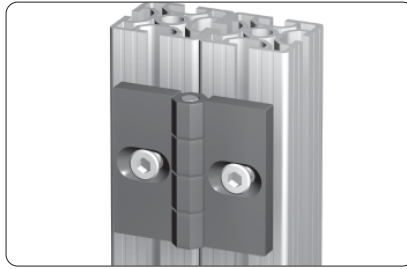

**Application**

Hinge with detachable fixing plug for different slot distances

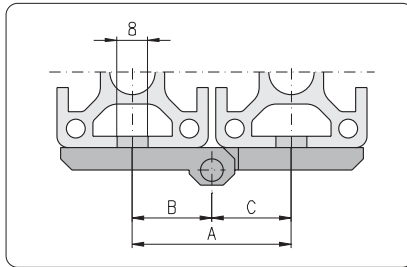

Doors with profile frames

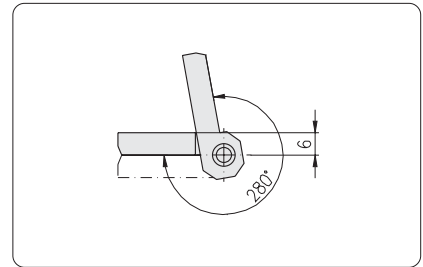

Swivel angle

**Technical data**

material: GD-Zn  
 surface: coated  
 colour: black  
 max. static load: 250 N

**Comments**

Countersink DIN 74 - M6 for countersunk screw DIN 7991 - M6

**Delivery unit**

Including 4 plugs for F- and E-slot

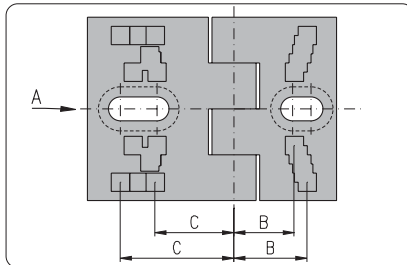

Distances for positioning plugs

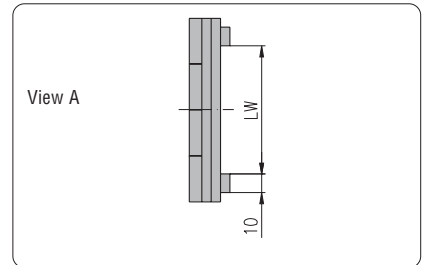

View A

**Possibilities of fastening**

**Legend**

LW = width  
 G = threaded plate 1.31.□□□  
 T = T-Nut 1.324.□□□

		short flange					
		slots					
		F		E3		E4	
B	LW	G	T	G	T	G	T
16.5	11	-	-	x	-	x	x
17.5	14.75	x	x	x	-	x	x
18.5	20.5	x	x	x	x	x	x
19	25.25	x	x	x	x	x	x
20	30	x	x	x	x	x	x

		long flange					
		slots					
		F		E3		E4	
C	LW	G	T	G	T	G	T
21	11	-	-	x	-	x	x
21.5	30	x	x	x	x	x	x
23.5	19	x	x	x	-	x	x
26	30	x	x	x	x	x	x
27.5	11	-	-	x	-	x	x
31	30	x	x	x	x	x	x

**Hinge 50x56**

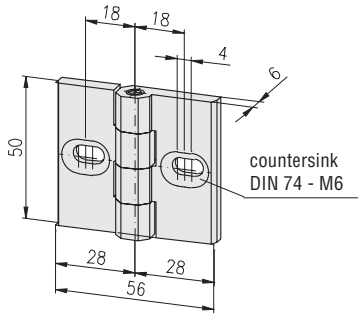

- 16 20 30 40 45 50 60

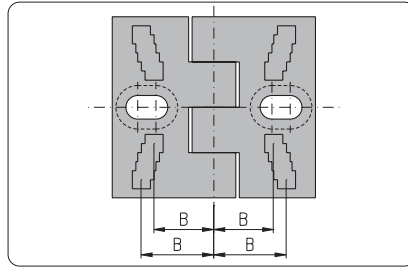

Rear view: plug assignment

**2 short flanges**

B
16.5
17.5
18.5
19
20

**Description**

Hinge 50x56

**Weight**

112 g

**Article-No.**

1.62.65056

**Hinge 50x68**

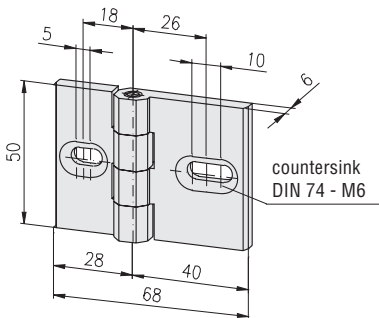

- 16 20 30 40 45 50 60

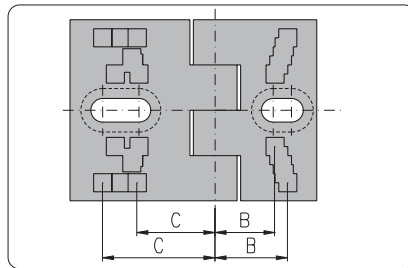

Rear view: plug assignment

**1 short flange, 1 long flange**

B	C
16.5	21
17.5	21.5
18.5	23.5
19	26
20	27.5
	31

**Description**

Hinge 50x68

**Weight**

130 g

**Article-No.**

1.62.65068

**Hinge 50x80**

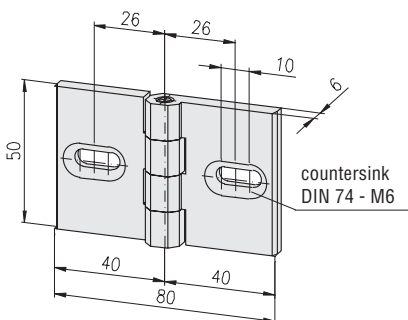

- 16 20 30 40 45 50 60

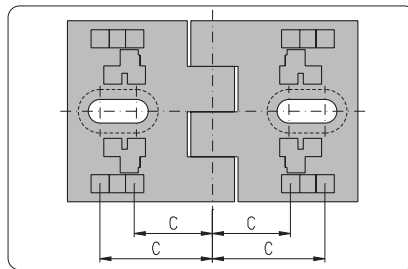

Rear view: plug assignment

**2 long flanges**

C
21
21.5
23.5
26
27.5
31

**Description**

Hinge 50x80

**Weight**

130 g

**Article-No.**

1.62.65080

**Alu hinges**

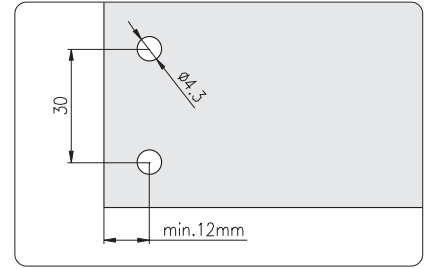

Distance of drill holes for panel elements of acrylic glass

**Application**

For doors of light material with or without profile frame, each hinge element can be combined

**Technical data**

material: aluminium Al Mg Si 0.5  
 strength: F 25  
 surface: neutral anodised  
 max. static load: 100 N

**Comments**

Countersink DIN 74 - M4 for countersunk screw DIN 7991 - M4

**Type A**

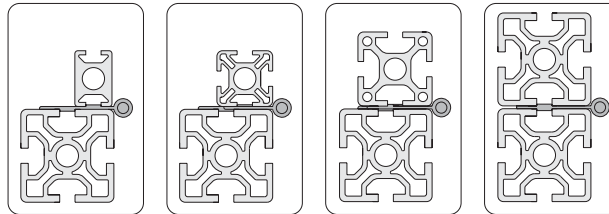

1 profile 20x30 1 profile 30x30 1 profile 40x40 2 profiles 50x50  
 1 profile 50x50 1 profile 50x50 1 profile 50x50

**Connection:**

- profile to profile
- leg built-in covered
- hinge elements:  
 Type A  
 Type A

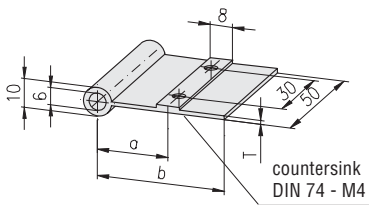

- 16 20 30 40 45 50 60

**Description**

	T	a	b	Weight	Article-No.
Hinge element Type A, PG 20, F	1.5	15.3	21	10 g	1.62.7120
Hinge element Type A, PG 30	1.5	20.3	29	11 g	1.62.7130
Hinge element Type A, PG 30	3.0	20.3	29	15 g	1.62.7130.030
Hinge element Type A, PG 40	1.5	25.3	37	13 g	1.62.7140
Hinge element Type A, PG 40	3.0	25.3	37	19 g	1.62.7140.030
Hinge element Type A, PG 50	1.5	30.3	45	14 g	1.62.7150
Hinge element Type A, PG 50	3.0	30.3	45	21 g	1.62.7150.030

**Type B**

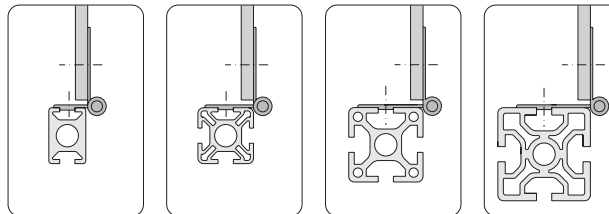

profile 20x30 profile 30x30 profile 40x40 profile 50x50

**Connection:**

- profile to panel element
- leg one side visible
- hinge elements:  
 Type A  
 Type B

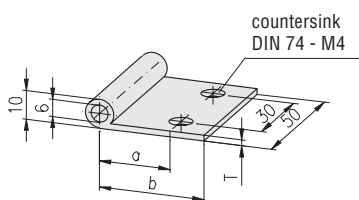

- 16 20 30 40 45 50 60

**Description**

	T	a	b	Weight	Article-No.
Hinge element Type B, PG 20	2.0	15.3	21	11 g	1.62.7220
Hinge element Type B, PG 20	3.0	15.3	21	13 g	1.62.7220.030
Hinge element Type B, PG 30	2.0	20.3	29	11 g	1.62.7230
Hinge element Type B, PG 30	3.0	20.3	29	13 g	1.62.7230.030
Hinge element Type B, PG 40	2.0	25.3	37	13 g	1.62.7240
Hinge element Type B, PG 40	3.0	25.3	37	16 g	1.62.7240.030
Hinge element Type B, PG 50	2.0	30.3	45	14 g	1.62.7250
Hinge element Type B, PG 50	3.0	30.3	45	18 g	1.62.7250.030



**Type C**

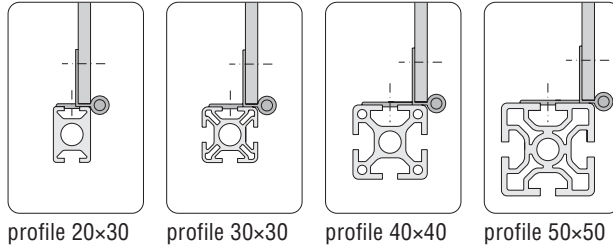

- Connection:**
- Profile to panel element
  - leg built-in covered
  - hinge elements:
    - Type A
    - Type C

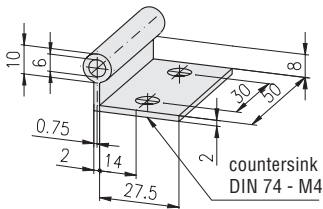

Description	Weight	Article-No.
Hinge element Type C, 30 mm	15 g	1.62.7330

**Press-fit pins**  
for alu hinges



Press-fit pin for one sided installation

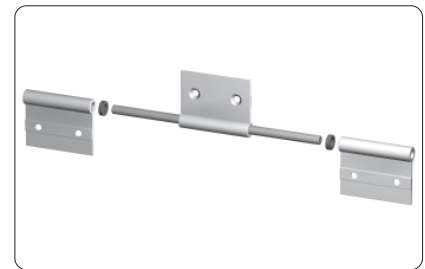

Press-fit pin for two sided installation

**Technical data**  
material: steel  
surface: galvanised

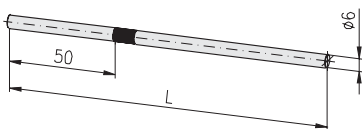

Description	L	Weight	Article-No.
Press-fit pin Ø6	100	29 g	1.62.7910
Press-fit pin Ø6	150	33 g	1.62.7915

**Spacer**

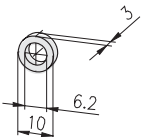

**Technical data**  
material: PE  
colour: black

Description	Weight	Article-No.
Spacer	1 g	1.62.7810

**Alu hinges, heavy**



**Application**

Hinge for higher loads such as doors with profile frames

**Technical data**

hinge  
 material: aluminium  
 strength: F25  
 surface: neutral anodised

**bolt**

Design steel  
 material: steel  
 Design stainless  
 material: stainless steel

**Comments**

Countersink DIN 74 - M8 for  
 countersunk screw DIN 7991 - M8

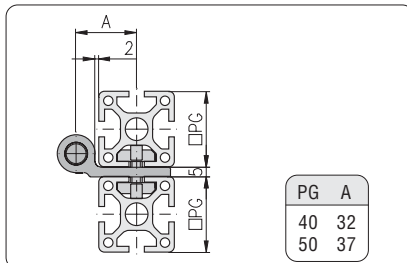

Application: Type 20

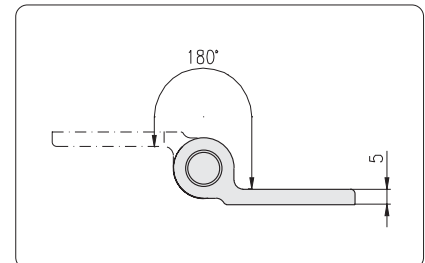

Swivel angle: Type 20

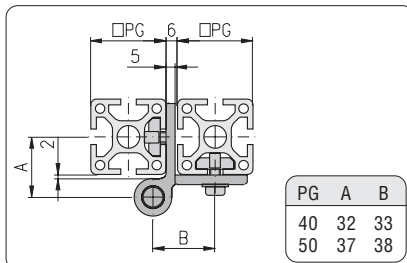

Application: Type 21, 22, 23, 31  
 with profiles PG 40/50

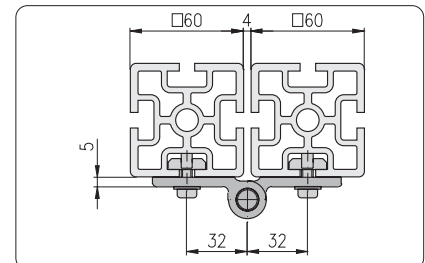

Application: Type 21, 22, 23, 31  
 with profiles PG 60

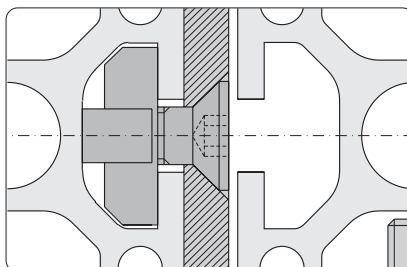

Application: Type 21, 22, 23, 31  
 with profiles PG 40/50

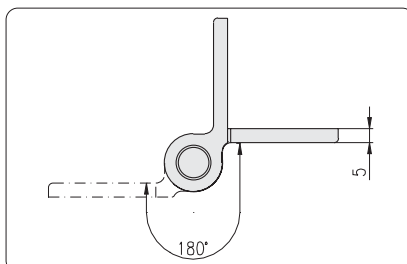

Swivel angle: Type 21, 22, 23, 31  
 at application with profiles PG 40/50

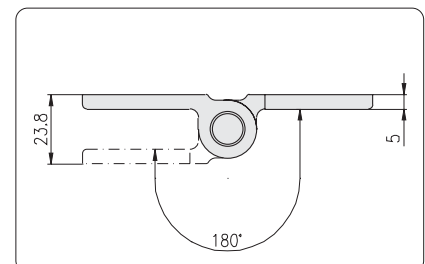

Swivel angle: Type 21, 22, 23, 31  
 at application with profiles PG 60

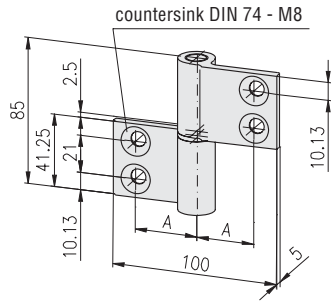

Description	Design	A	Weight	Article-No.
Alu hinge, heavy, type 20, PG 40	steel	32	166 g	1.62.842032085
Alu hinge, heavy, type 20, PG 50	steel	37	166 g	1.62.842037085
Alu hinge, heavy, type 20, PG 40	stainless	32	166 g	1.62.842032085V
Alu hinge, heavy, type 20, PG 50	stainless	37	166 g	1.62.842037085V

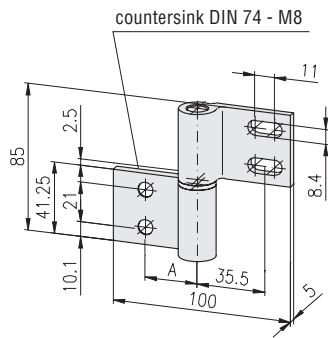

Description	Design	A	Weight	Article-No.
Alu hinge, heavy, type 21, PG 40/60	steel	32	159 g	1.62.842132085
Alu hinge, heavy, type 21, PG 50	steel	37	159 g	1.62.842137085
Alu hinge, heavy, type 21, PG 40/60	stainless	32	159 g	1.62.842132085V
Alu hinge, heavy, type 21, PG 50	stainless	37	159 g	1.62.842137085V

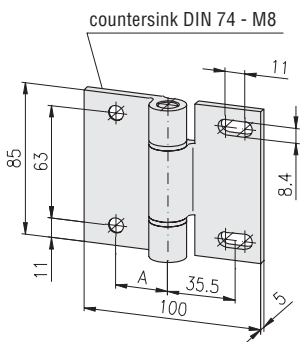

Description	Design	A	Weight	Article-No.
Alu hinge, heavy, type 22, PG 40/60	steel	32	261 g	1.62.842232085
Alu hinge, heavy, type 22, PG 50	steel	37	261 g	1.62.842237085
Alu hinge, heavy, type 22, PG 40/60	stainless	32	261 g	1.62.842232085V
Alu hinge, heavy, type 22, PG 50	stainless	37	261 g	1.62.842237085V

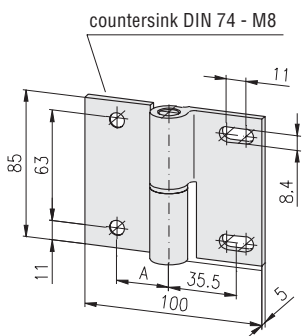

Description	Design	A	Weight	Article-No.
Alu hinge, heavy, type 23, PG 40/60	steel	32	258 g	1.62.842332085
Alu hinge, heavy, type 23, PG 50	steel	37	258 g	1.62.842337085
Alu hinge, heavy, type 23, PG 40/60	stainless	32	258 g	1.62.842332085V
Alu hinge, heavy, type 23, PG 50	stainless	37	258 g	1.62.842337085V

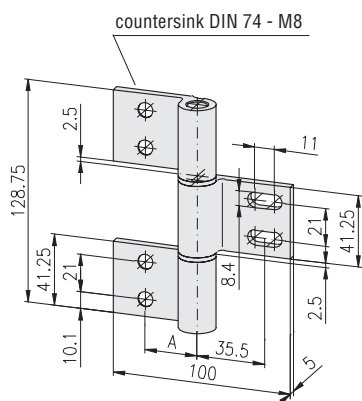

Description	Design	A	Weight	Article-No.
Alu hinge, heavy, type 31, PG 40/60	steel	32	245 g	1.62.843132128
Alu hinge, heavy, type 31, PG 50	steel	37	245 g	1.62.843137128
Alu hinge, heavy, type 31, PG 40/60	stainless	32	245 g	1.62.843132128V
Alu hinge, heavy, type 31, PG 50	stainless	37	245 g	1.62.843137128V

**Joints**  
with / without clamping lever

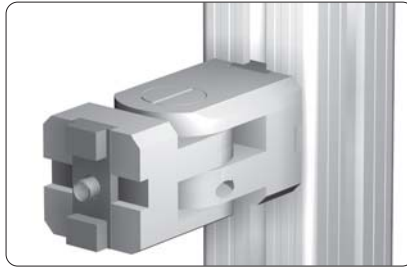

The MayTec clamping system allows backlash free adjusting and clamping



The joint can be locked with the adjustable clamping lever

**Application**

To enable infinitely variable adjusting and swivelling of profiles

**Technical data**

material: steel  
surface: galvanised

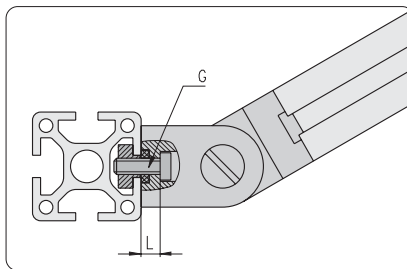

Mounting on profile side

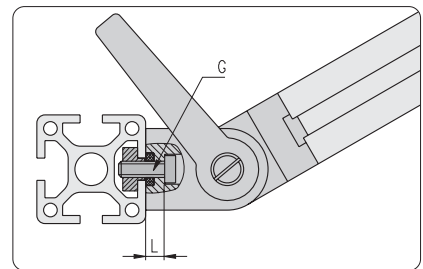

Mounting on profile side

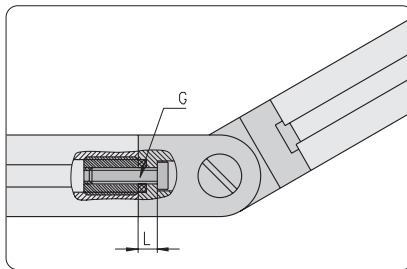

Mounting on profile end

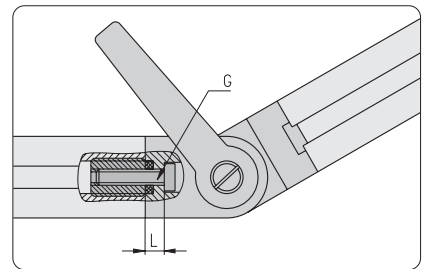

Mounting on profile end

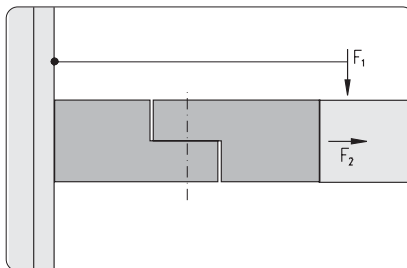

max. loads		
Joint	F1 <sub>max</sub>	F2 <sub>max</sub>
20×20	10 Nm	2,000 N
30×30	30 Nm	4,000 N
30×50	50 Nm	4,000 N
30×100	100 Nm	8,000 N
30×100 <sup>1)</sup>	200 Nm	8,000 N
40×40	50 Nm	6,000 N
50×50	60 Nm	10,000 N

<sup>1)</sup> with fastening plate

**Comments**

Mounting with:

- cap-screw DIN 6912
- washer DIN 433

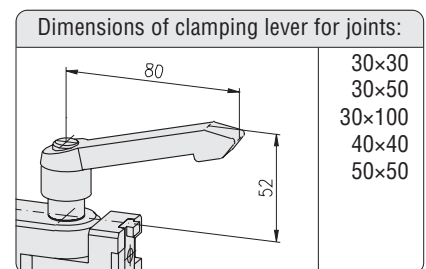
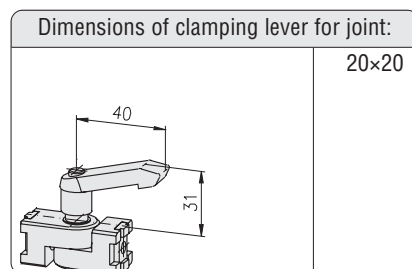

**20x20**

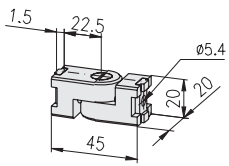

Description	G	L	Weight	Article-No.
Joint 20x20	M5	6.5	97 g	1.63.02021
Joint 20x20 with clamping lever	M5	6.5	114 g	1.63.12021
Anti-twist device for joint, H, L20			8 g	1.63.02022
Anti-twist device for joint, F, L20			8 g	1.63.02023

**30x30**

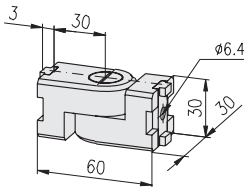

Description	G	L	Weight	Article-No.
Joint 30x30	M6	7.5	315 g	1.63.03031
Joint 30x30 with clamping lever	M6	7.5	380 g	1.63.13031
Anti-twist device for joint, L30			28 g	1.63.03032

**30x50**

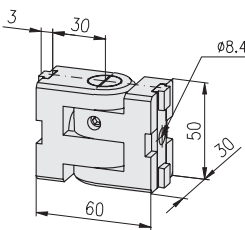

Description	G	L	Weight	Article-No.
Joint 30x50	M8	7.5	533 g	1.63.03051
Joint 30x50 with clamping lever	M8	7.5	600 g	1.63.13051
Anti-twist device for joint, L30			28 g	1.63.03032
Anti-twist device for joint, L50			33 g	1.63.03052

**30x100**

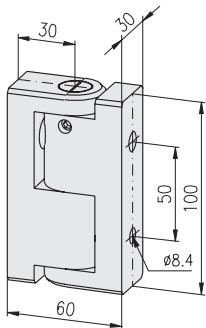

**Comments**

To increase the load capacity on hinge 30x100  
 ➔ fastening plate 30x150, 1.47.60315

Description	G	L	Weight	Article-No.
Joint 30x100	M8	7.5	1,098 g	1.63.03101
Joint 30x100 with clamping lever	M8	7.5	1,160 g	1.63.13101

**40x40**

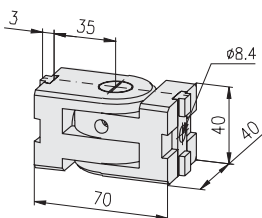

Description	G	L	Weight	Article-No.
Joint 40x40	M8	7.5	674 g	1.63.04041
Joint 40x40 with clamping lever	M8	7.5	739 g	1.63.14041
Anti-twist device for joint, L40			28 g	1.63.04042

**50x50**

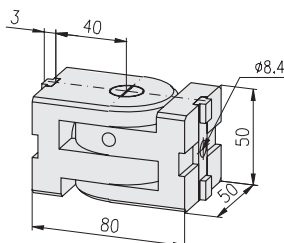

Description	G	L	Weight	Article-No.
Joint 50x50	M8	7.5	1,244 g	1.63.05051
Joint 50x50 with clamping lever	M8	7.5	1,300 g	1.63.15051
Anti-twist device for joint, L50			33 g	1.63.03052

**Joints Zn  
with / without clamping lever**



The MayTec clamping system allows backlash free adjusting and clamping



The joint can be locked with the adjustable clamping lever

**Application**

To enable infinitely variable adjusting and swivelling of profiles

**Technical data**

material: GD-Zn  
surface: aluminium coloured powder-coated

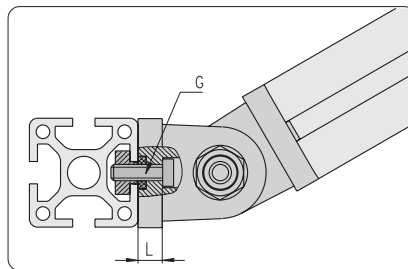

Mounting on profile side

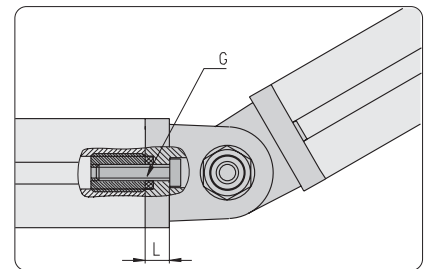

Mounting on profile end

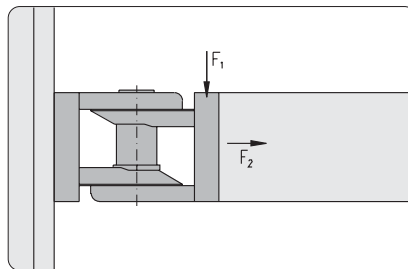

max. loads		
Joint	F1 <sub>max</sub>	F2 <sub>max</sub>
30×30	500 N	500 N
40×40	750 N	750 N
45×45	750 N	750 N

**Comments**

- Mounting with:
- cap screw DIN 6912
  - washer DIN 433

**30×30**

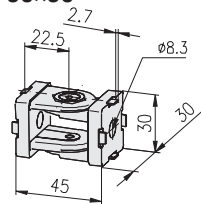

**40×40**

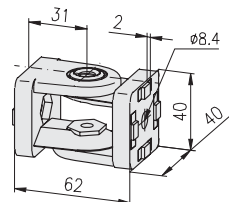

**45×45**

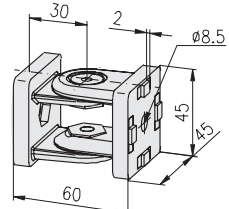

**Description**

	G	L	Weight	Article-No.
Joint Zn 30×30	M8	7.0	124 g	1.63.51030030
Joint Zn 30×30 with clamping lever	M8	7.0	147 g	1.63.52030030

**Description**

	G	L	Weight	Article-No.
Joint Zn 40×40	M8	9.0	300 g	1.63.51040040
Joint Zn 40×40 with clamping lever	M8	9.0	344 g	1.63.52040040

**Description**

	G	L	Weight	Article-No.
Joint Zn 45×45	M8	8.0	320 g	1.63.51045045
Joint Zn 45×45 with clamping lever	M8	8.0	366 g	1.63.52045045

**Mounting blocks  
screw-type**

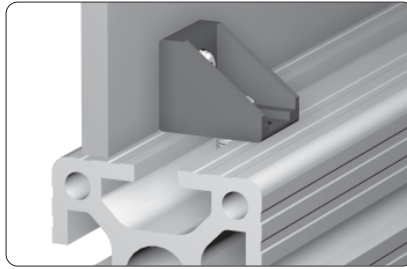

**Application**

For mounting of panels

**Technical data**

Mounting block  
material: PA-GF  
colours: grey, black  
Threaded plate  
material: steel  
surface: galvanised

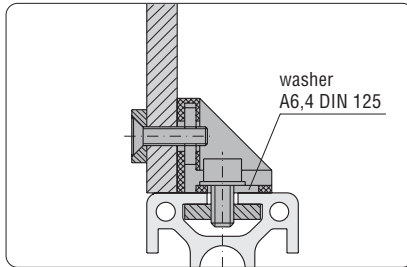

Mounting on the profile with threaded plate or T-Nut

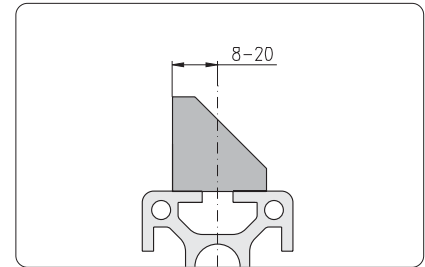

Adjustable position

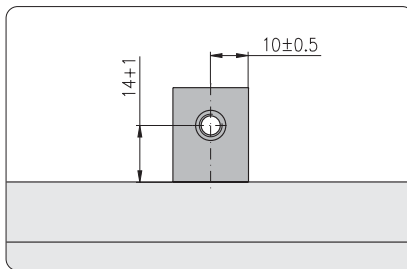

**Comments**

A 'floating' nut allows additional tolerance in the panel mounting holes.

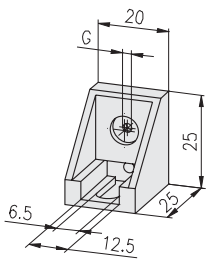

Description	G	Colour	Weight	Article-No.
Mounting block screw type M3	M3	grey	9 g	1.64.10M3.1
Mounting block screw type M3	M3	black	9 g	1.64.10M3.2
Mounting block screw type M4	M4	grey	9 g	1.64.10M4.1
Mounting block screw type M4	M4	black	9 g	1.64.10M4.2
Mounting block screw type M5	M5	grey	9 g	1.64.10M5.1
Mounting block screw type M5	M5	black	9 g	1.64.10M5.2
Mounting block screw type M6	M6	grey	9 g	1.64.10M6.1
Mounting block screw type M6	M6	black	9 g	1.64.10M6.2

**Mounting block GD-Zn**

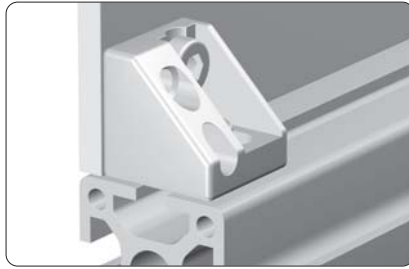

**Application**

For mounting of panels

**Technical data**

material: GD-Zn

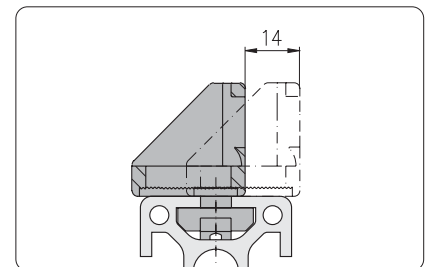
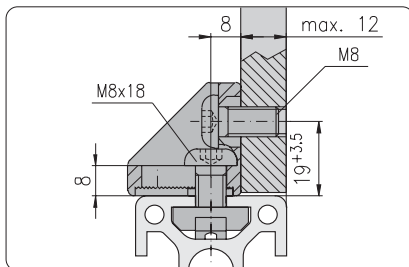
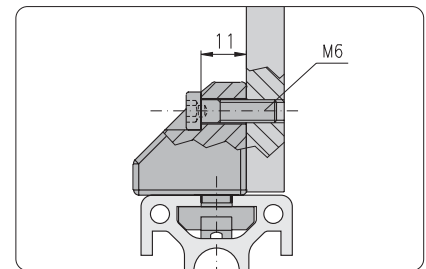
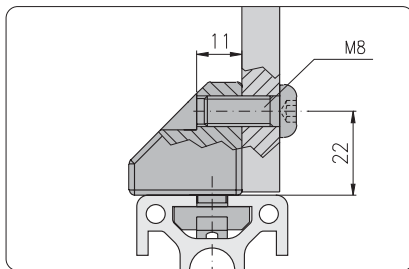
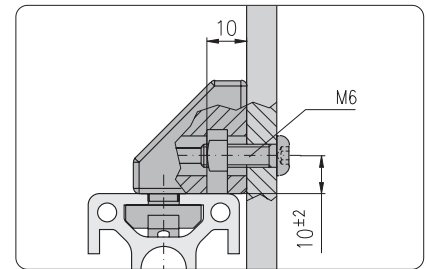
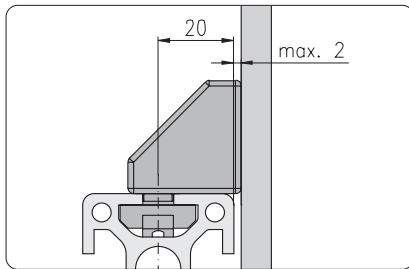

Anti-twistable mounting in steps of 1 mm

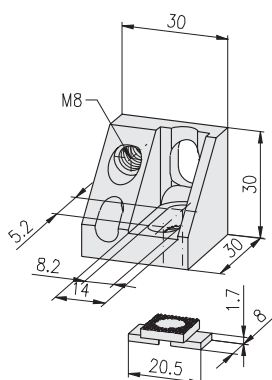
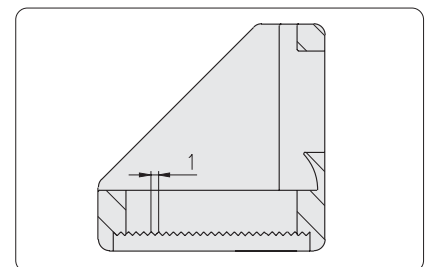

Description	G	Surface	Weight	Article-No.
Mounting block GD-Zn	M8	natural	68 g	1.64.153030.1
Mounting block GD-Zn	M8	black	68 g	1.64.153030.2



**Mounting blocks for subsequent insertion**

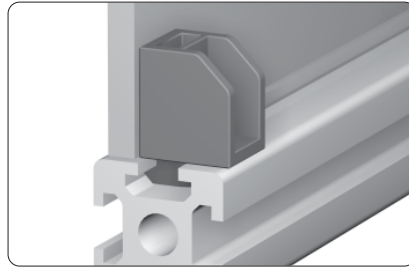

**Application**

For the mounting of panels with subsequent insertion  
Variable mounting position of panels with distancing plate

**Mounting block H**

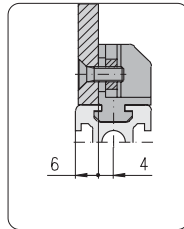
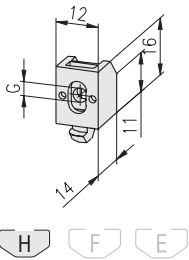

H-slot

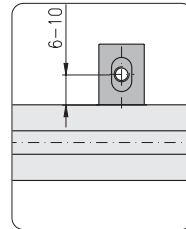

Tolerance equalisation: 4 mm

**Technical data**

material: PA-GF  
colour: black  
square nut: steel, galvanised  
max. static load: 100 N, rectangular to slot

Description	G	Weight	Article-No.
Mounting block H	M4	2.6 g	1.64.2H2M4.2

**Technical data**

material: PA-GF  
colour: black

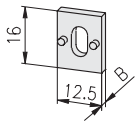

Description	B	Weight	Article-No.
Distancing plate for mounting block H	1	0.2 g	1.64.xH01
Distancing plate for mounting block H	2	0.4 g	1.64.xH02
Distancing plate for mounting block H	3	0.6 g	1.64.xH03
Distancing plate for mounting block H	4	0.8 g	1.64.xH04

**Mounting blocks F and E**

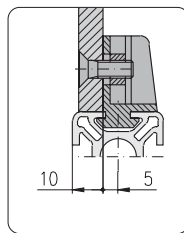

F-slot

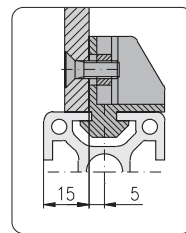

E3-slot

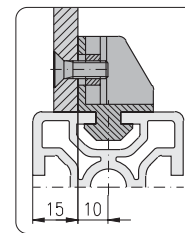

E4-slot

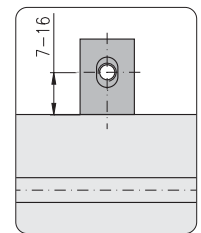

Tolerance equalisation: 9 mm

**Technical data**

material: PA-GF  
colours: grey, black  
square nut: steel, galvanised  
max. static load: 250 N, rectangular to slot

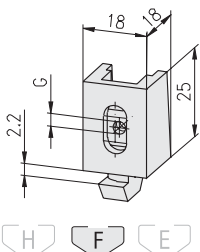

Description	G	Colour	Weight	Article-No.
Mounting block F	M4	grey	9 g	1.64.2F2M4.1
Mounting block F	M4	black	9 g	1.64.2F2M4.2
Mounting block F	M5	grey	9 g	1.64.2F2M5.1
Mounting block F	M5	black	9 g	1.64.2F2M5.2
Mounting block F	M6	grey	9 g	1.64.2F2M6.1
Mounting block F	M6	black	9 g	1.64.2F2M6.2

**Mounting blocks E**

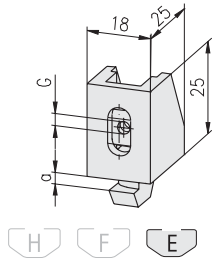

Description	G	Colour	a	Weight	Article-No.
Mounting block E3	M4	grey	3.0	10.5 g	1.64.2E3M4.1
Mounting block E3	M4	black	3.0	10.5 g	1.64.2E3M4.2
Mounting block E3	M5	grey	3.0	10.1 g	1.64.2E3M5.1
Mounting block E3	M5	black	3.0	10.1 g	1.64.2E3M5.2
Mounting block E3	M6	grey	3.0	9.6 g	1.64.2E3M6.1
Mounting block E3	M6	black	3.0	9.6 g	1.64.2E3M6.2
Mounting block E4	M4	grey	4.0	10.6 g	1.64.2E4M4.1
Mounting block E4	M4	black	4.0	10.6 g	1.64.2E4M4.2
Mounting block E4	M5	grey	4.0	10.2 g	1.64.2E4M5.1
Mounting block E4	M5	black	4.0	10.2 g	1.64.2E4M5.2
Mounting block E4	M6	grey	4.0	9.9 g	1.64.2E4M6.1
Mounting block E4	M6	black	4.0	9.9 g	1.64.2E4M6.2

**Technical data**

material: PA-GF  
colours: grey, black

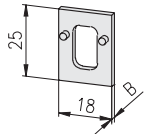

Description	B	Colour	Weight	Article-No.
Distancing plate for mounting block FE	2	grey	0.5 g	1.64.2x02.1
Distancing plate for mounting block FE	2	black	0.5 g	1.64.2x02.2
Distancing plate for mounting block FE	3	grey	0.8 g	1.64.2x03.1
Distancing plate for mounting block FE	3	black	0.8 g	1.64.2x03.2
Distancing plate for mounting block FE	5	grey	1.3 g	1.64.2x05.1
Distancing plate for mounting block FE	5	black	1.3 g	1.64.2x05.2

**Distancing plate, thin**

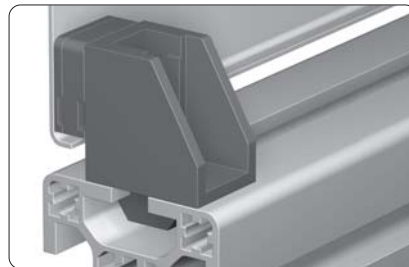

**Application**

For the mounting of folded panels

**Technical data**

material: PA-GF  
colours: grey, black

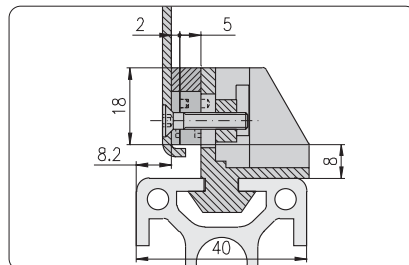

Description	B	Colour	Weight	Article-No.
Distancing plate, thin, for mounting block FE	2	grey	0.3 g	1.64.2x102.1
Distancing plate, thin, for mounting block FE	2	black	0.3 g	1.64.2x102.2
Distancing plate, thin, for mounting block FE	3	grey	0.6 g	1.64.2x103.1
Distancing plate, thin, for mounting block FE	3	black	0.6 g	1.64.2x103.2
Distancing plate, thin, for mounting block FE	5	grey	0.9 g	1.64.2x105.1
Distancing plate, thin, for mounting block FE	5	black	0.9 g	1.64.2x105.2

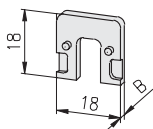

**Mounting clamp blocks for subsequent insertion**

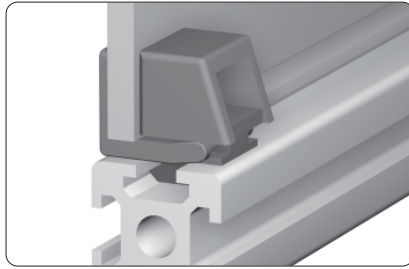

**Application**

Mounting of panels with clamps, without drilling and screwing  
 For subsequent insertion:  
 Variable mounting position of panels with distance plates

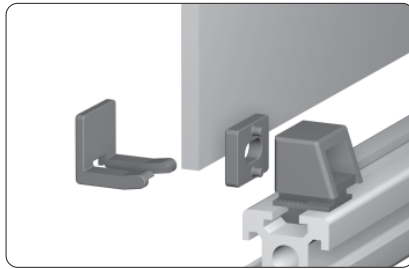

The distance plates are positioned and fastened by pins, it is possible to mount several distance plates in series

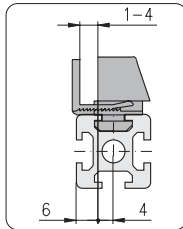

H-slot

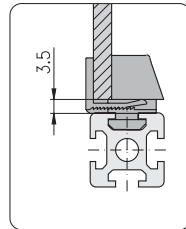

Installation dimensions

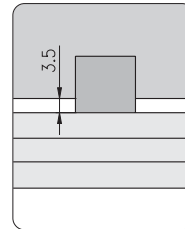

Installation dimensions

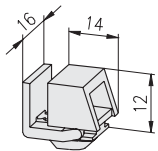

**Technical data**

- material: PA-GF
- colour: black
- max. static load:
  - towards clamp block: 110 N
  - towards slider: 30 N

**Description**

Mounting clamp block H

**Weight**

3.4 g

**Article-No.**

1.64.3H2

**Technical data**

- material: PA-GF
- colour: black

**Description**

Description	B	Weight	Article-No.
Distancing plate for mounting clamp block H 1	1	0.2 g	1.64.xH01
Distancing plate for mounting clamp block H 2	2	0.4 g	1.64.xH02
Distancing plate for mounting clamp block H 3	3	0.6 g	1.64.xH03
Distancing plate for mounting clamp block H 4	4	0.8 g	1.64.xH04

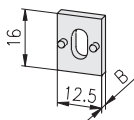

**Mounting clamp blocks for subsequent insertion**

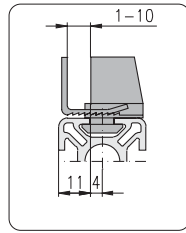

F-slot

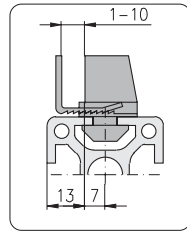

E3-slot

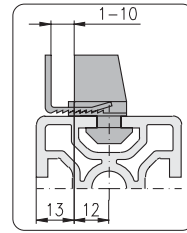

E4-slot

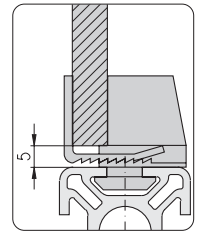

Installation dimensions

**Technical data**

material: PA-GF

colour: black

max. static load:

- towards clamp block: 250 N
- towards slider: 50 N

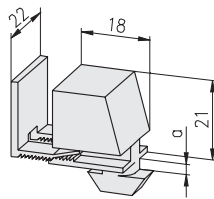
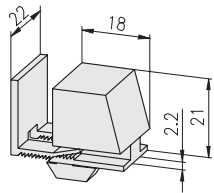

**Description**

Mounting clamp block F

**Weight**

7.5 g

**Article-No.**

1.64.3F2

**Description**

Mounting clamp block E3

**a**

3.0

**Weight**

8.0 g

**Article-No.**

1.64.3E3

Mounting clamp block E4

4.0

8.0 g

1.64.3E4

**Technical data**

material: PA-GF

colour: black

**Description**

Distancing plate for mounting clamp block FE 2

**B**

2

**Weight**

0.6 g

**Article-No.**

1.64.3x02

Distancing plate for mounting clamp block FE 3

3

0.9 g

1.64.3x03

Distancing plate for mounting clamp block FE 5

5

1.4 g

1.64.3x05

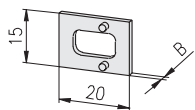

**Mounting clamp blocks SL for subsequent insertion**

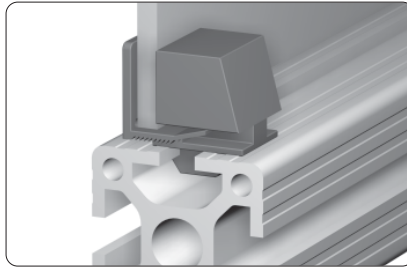

**Application**

As mounting clamp block, however: For safety's sake it is only possible to be opened with special tools

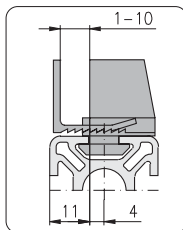
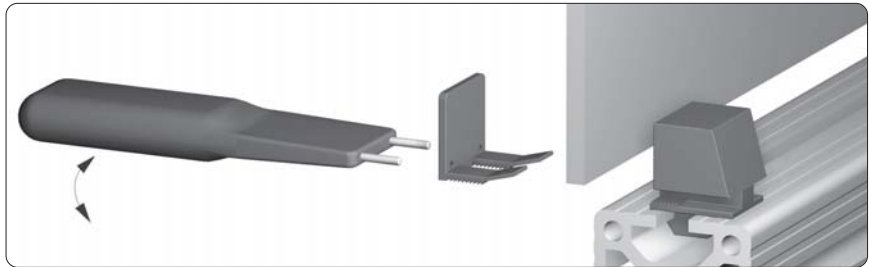

F-slot

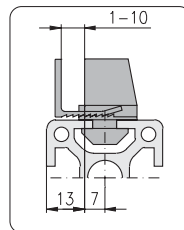

E3-slot

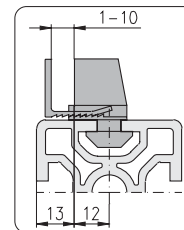

E4-slot

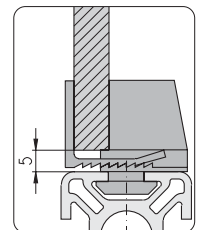

Installation dimensions

**Technical data**

- material: PA-GF
- colour: black
- max. static load:
  - towards clamp block: 250 N
  - towards slider: 50 N

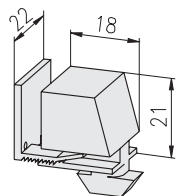

**Description**

Description	Weight	Article-No.
Mounting clamp block F, SL	7.5 g	1.64.4F2
Mounting clamp block E3, SL	8.0 g	1.64.4E3
Mounting clamp block E4, SL	8.0 g	1.64.4E4

**Technical data**

- material: PA-GF
- colour: black

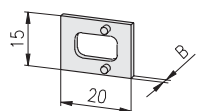

**Description**

Description	B	Weight	Article-No.
Distancing plate for mounting clamp block FE 2		0.6 g	1.64.3x02
Distancing plate for mounting clamp block FE 3		0.9 g	1.64.3x03
Distancing plate for mounting clamp block FE 5		1.4 g	1.64.3x05

**Technical data**

- material: PA-GF
- colour: red
- steel bolt: hardened

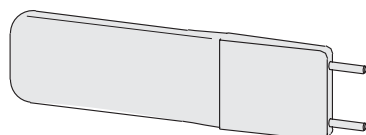

**Description**

Description	Weight	Article-No.
Tool for mounting clamp block SL	23 g	1.64.4W

**Quick locks**

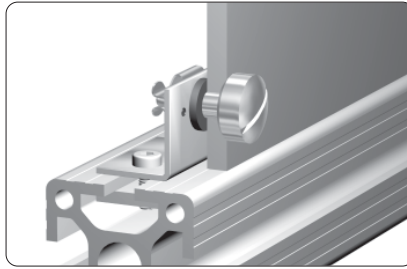

**Application**

Mounting element for quick mounting and dismounting of covers

**Comments**

open: by 1/4-turn  
close: by push in

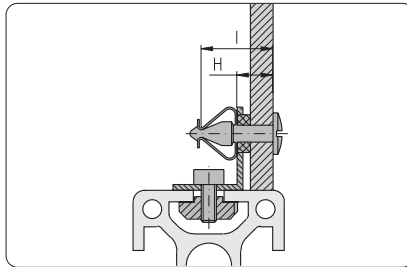

Fastening without washer  
 $H_{max} = S_{retaining\ ring} + \text{panel thickness}$

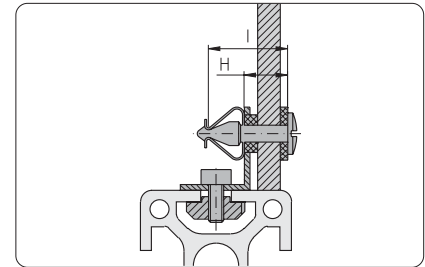

Fastening with washer  
 $H_{max} = S_{retaining\ ring} + \text{panel thickness} + S_{washer}$

**Technical data (assembly)**

drilling diameter  
in the covers: 7 mm  
max. static load: 900 N  
life time: ca. 10.000 operations

**Mounting angle**

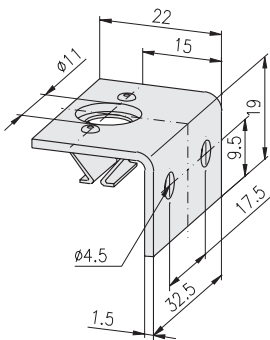

**Technical data**

material: steel  
surface: galvanised

**Mounting elements:**

- F-slot:
- T-Nut, with leaf spring F, 2xM4 1.324.F2M4.25
  - threaded plate F, M4 1.31.FM4
  - spring nut F, M4 1.33.FM4
  - T-slot nut F, M4 1.34.10FM4
- E-slot:
- T-Nut, with leaf spring E, 2xM4 1.324.E2M4.25
  - spring nut E, M4 1.33.EM4
  - T-slot nut E, M4 1.34.10EM4
  - rhomboid T-slot nut E, M4 1.34.20EM4

Description	Weight	Article-No.
Mounting angle	14 g	1.64.5101

**Retaining rings**

**Technical data**

material: neoprene  
hardness: 55 Shore A  
temperature range: - 50°C to + 90°C

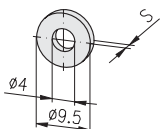

Description	S	Weight	Article-No.
Retaining ring	1.7	1.3 g	1.64.5217
Retaining ring	2.5	1.8 g	1.64.5225
Retaining ring	4.0	3.5 g	1.64.5240
Retaining ring	5.0	4.0 g	1.64.5250
Retaining ring	6.0	4.5 g	1.64.5260

**Sealing washers**

**Technical data**

material: neoprene  
 hardness: 55 Shore A  
 temperature range: - 50°C to + 90°C

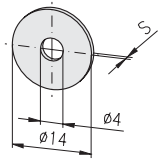

Description	S	Weight	Article-No.
Sealing washer	0.5	0.8 g	1.64.5305
Sealing washer	1.0	1.7 g	1.64.5310
Sealing washer	1.5	2.5 g	1.64.5315
Sealing washer	2.0	3.3 g	1.64.5320

**Round head bolts**

**Technical data**

material: brass  
 surface: nickel-plated

**Comments**

Mounting dimension "H" see mounting sketch

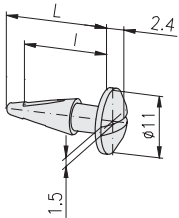

Description	H <sub>max</sub>	L	I	Weight	Article-No.
Round head bolt	3.7	16.6	14.4	4.0 g	1.64.5416
Round head bolt	4.7	17.6	15.4	4.0 g	1.64.5417
Round head bolt	5.7	18.6	16.4	4.0 g	1.64.5418
Round head bolt	6.9	19.8	17.6	4.5 g	1.64.5419
Round head bolt	7.7	20.6	18.4	5.0 g	1.64.5420
Round head bolt	8.9	21.8	19.6	5.0 g	1.64.5421
Round head bolt	9.7	22.6	20.4	6.0 g	1.64.5422
Round head bolt	10.7	23.6	21.4	6.0 g	1.64.5423

**Knurled head bolts**

**Technical data**

material: brass  
 surface: nickel-plated

**Comments**

Mounting dimension "H" see mounting sketch

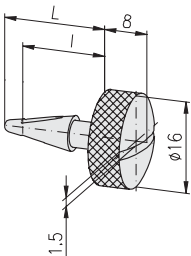

Description	H <sub>max</sub>	L	I	Weight	Article-No.
Knurled head bolt	3.7	16.6	14.4	14.0 g	1.64.5516
Knurled head bolt	4.7	17.6	15.4	14.0 g	1.64.5517
Knurled head bolt	5.7	18.6	16.4	14.0 g	1.64.5518
Knurled head bolt	6.9	19.8	17.6	14.0 g	1.64.5519
Knurled head bolt	7.7	20.6	18.4	15.0 g	1.64.5520
Knurled head bolt	8.9	21.8	19.6	15.0 g	1.64.5521
Knurled head bolt	10.7	23.6	21.4	15.0 g	1.64.5523

**Wing head bolts**

**Technical data**

material: brass  
 surface: nickel-plated

**Comments**

Mounting dimension "H" see mounting sketch

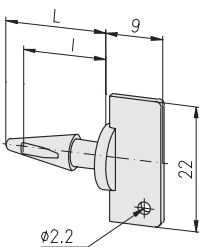

Description	H <sub>max</sub>	L	I	Weight	Article-No.
Wing head bolt	3.7	16.6	14.4	5.8 g	1.64.5616
Wing head bolt	4.7	17.6	15.4	5.8 g	1.64.5617
Wing head bolt	5.7	18.6	16.4	5.8 g	1.64.5618
Wing head bolt	6.9	19.8	17.6	5.8 g	1.64.5619
Wing head bolt	7.7	20.6	18.4	6.3 g	1.64.5620
Wing head bolt	8.9	21.8	19.6	6.3 g	1.64.5621
Wing head bolt	9.7	22.6	20.4	6.3 g	1.64.5622
Wing head bolt	10.7	23.6	21.4	6.3 g	1.64.5623

**Bullet catches**

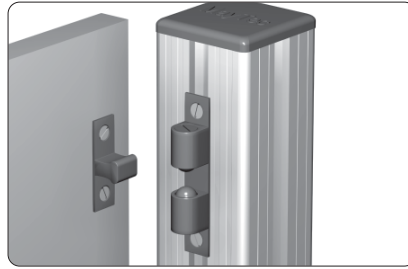

**Application**

Lock for swinging and sliding doors

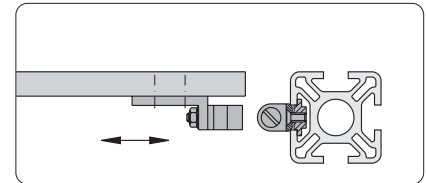
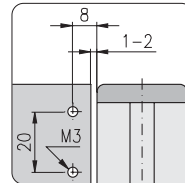
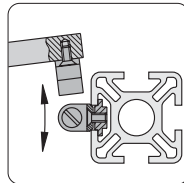

**Technical data**

material: brass  
 colour: natural  
 retention force: adjustable

**Comments**

Countersink DIN 74 - M4 for countersunk screw DIN 7991 - M4

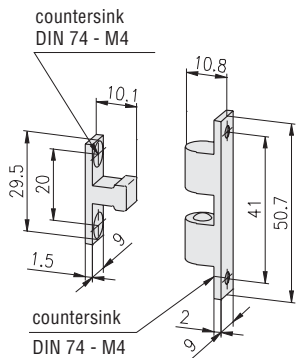

**Description**

Bullet catch 9x50

**Weight**

25.0 g

**Article-No.**

1.65.1101

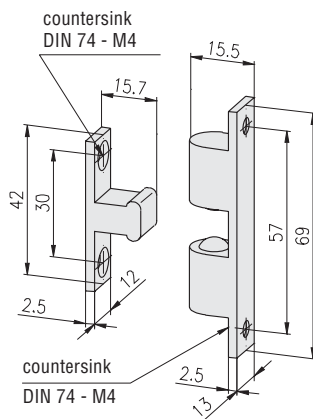

**Comments**

Countersink DIN 74 - M4 for countersunk screw DIN 7991 - M4

**Description**

Bullet catch 13x69

**Weight**

72.0 g

**Article-No.**

1.65.1102



**Bullet catch PA**

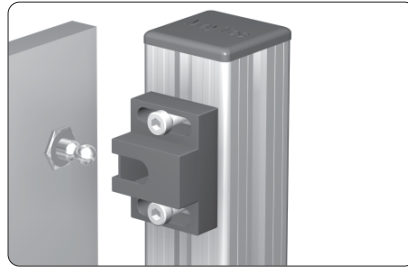

**Application**

Lock for swinging and sliding doors

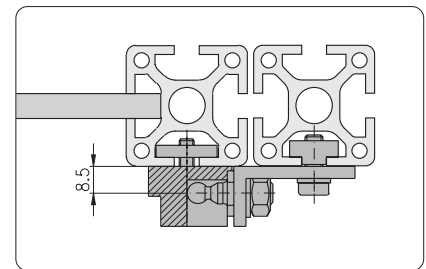
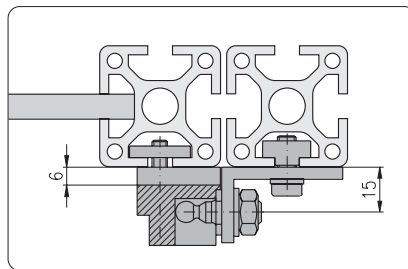
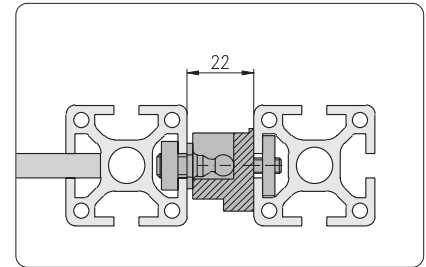
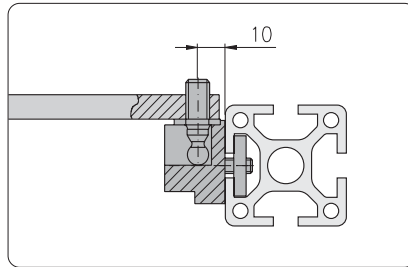

Fastening of the bolt with angle 25x40, Ø8.7 ↗ 1.46.115

Fastening of the bolt with angle 20x47, M8 ↗ 1.65.1301

**Bullet catch PA**

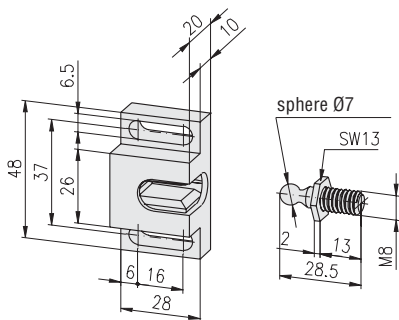

**Technical data**

capsule: PA-GF, black  
bolt: steel, galvanised  
retention force: 45 N

**Description**

Bullet catch PA

**Weight**

23.0 g

**Article-No.**

1.65.1201

**Angle**

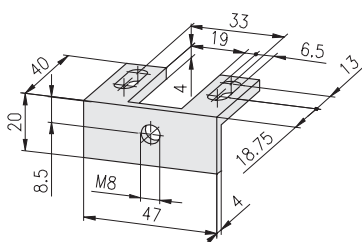

**Technical data**

material: aluminium  
strength: F22  
surface: natural anodised

**Description**

Angle 20x47, M8

**Weight**

16.0 g

**Article-No.**

1.65.1301

**Magnetic lock PA**

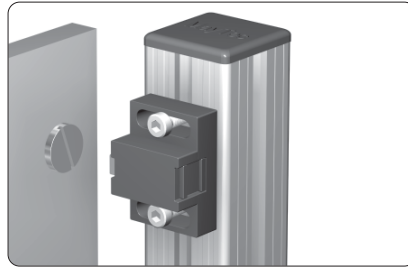

**Application**

Lock for swinging and sliding doors

**Technical data**

capsule: PA-GF, black  
 flat head screw: steel, galvanised  
 retention force: y = 40 N  
 x = 25 N

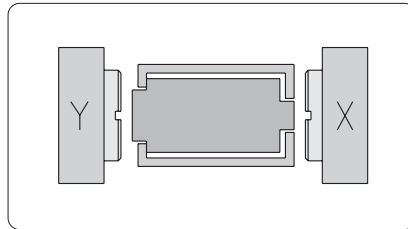

**Comments**

Different force  
 y = large force  
 x = small force

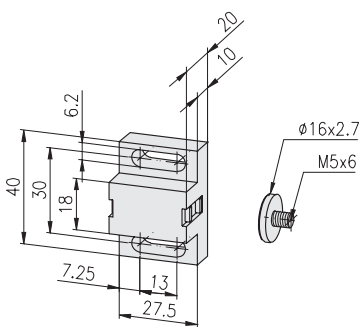
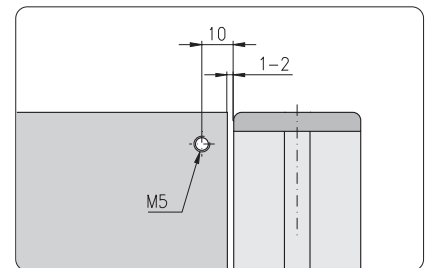
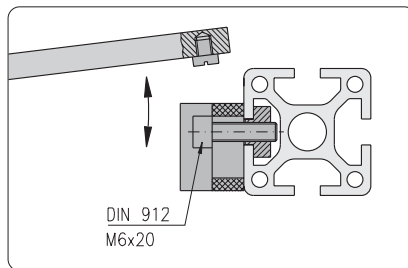

**Description**

Magnetic lock PA

**Weight**

38.0 g

**Article-No.**

1.65.2101

**Angle bracket  
 for magnetic lock PA**

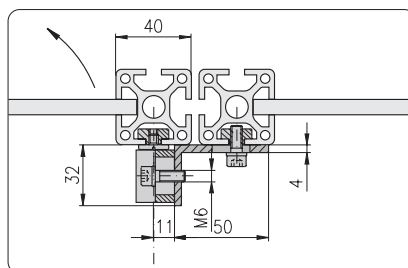

**Technical data**

material: aluminium  
 strength: F22  
 surface: natural anodised

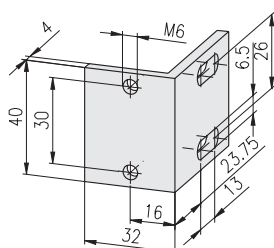

**Description**

Angle bracket for magnetic lock PA

**Weight**

32.0 g

**Article-No.**

1.65.2301

**Lock GD-Zn**



**Application**

Lock with sprung bolt for easy closing of doors and panels, including separate slot fastening capability

**Technical data**

capsule: GD Zn, painted silver  
 handle: PA, black  
 bolt: stainless steel

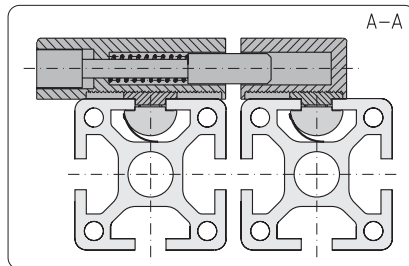

Slot fastening capability

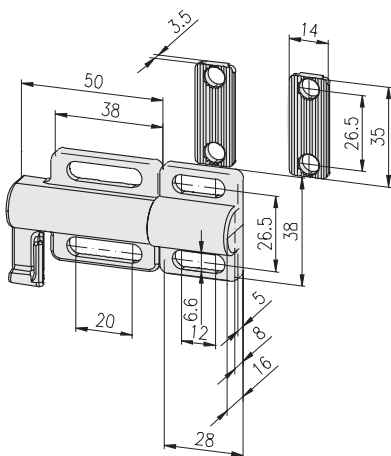
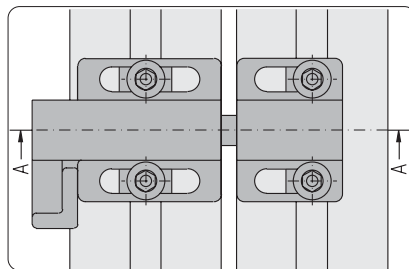

**Description**

Lock GD-Zn

**Weight**

120,0 g

**Article-No.**

1.65.2538078

**Cylinder locks**

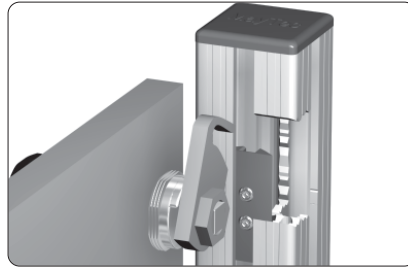

**Application**

Locking system for swinging and sliding doors

**Comments**

By turning the lock body the cylinder lock is insertable left or right

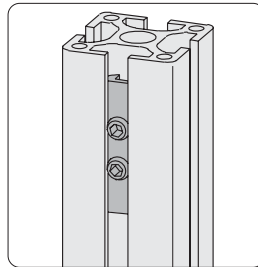

Insertion of the latch

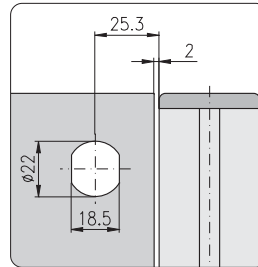

Fixing dimensions for the cylinder lock

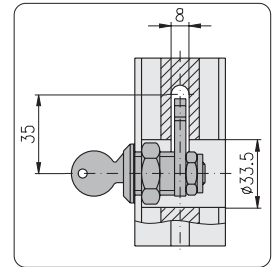

Fixing dimensions for the cylinder lock

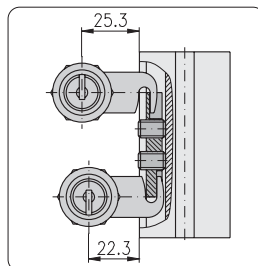

Latch for two different bore spaces

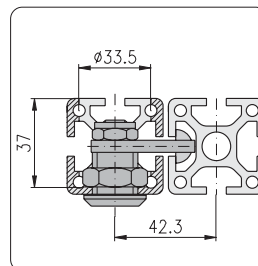

Swinging door with profile frame made of profile 40x40

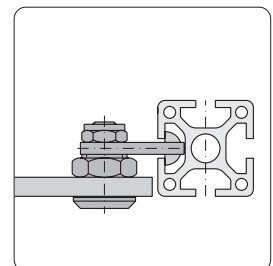

Swinging door without profile frame

**Technical data**

capsule: GD Zn, galvanised  
tongue, nut, screw: steel, galvanised

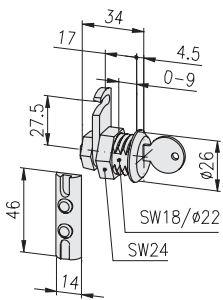

**Description**

Cylinder lock with 2 keys

**Weight**

82.0 g

**Article-No.**

1.65.3101

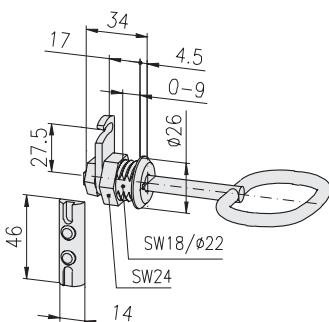

**Comments**

Key with double beard  $\phi 8$  mm

**Description**

Cylinder lock with double beard insert

**Weight**

150.0 g

**Article-No.**

1.65.3102

**Cylinder locks with security latch**

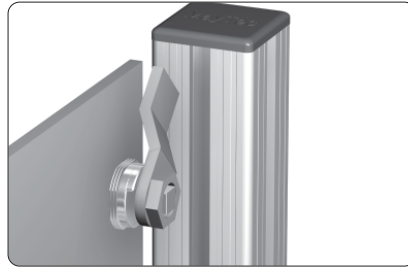

**Application**  
Lock for swinging door

**Comments**  
Security latch  
Jolting- and vibrationless by integral lock

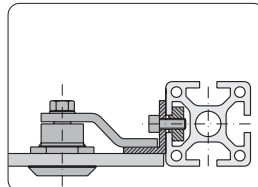

Installation variant with mounting angle

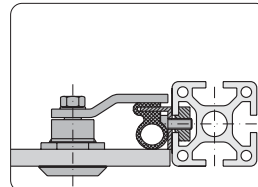

Installation variant with seal

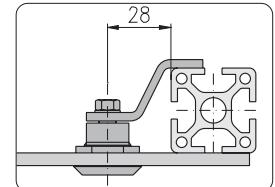

Installation variant

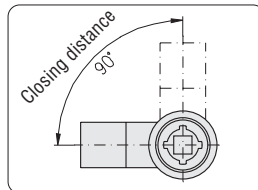

Closing distance

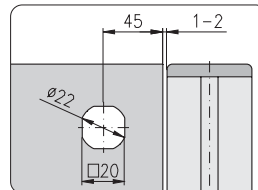

Drilling pattern

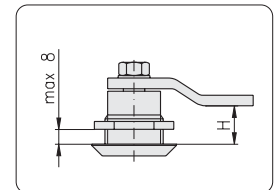

Security latch dimension H

**Cylinder locks**

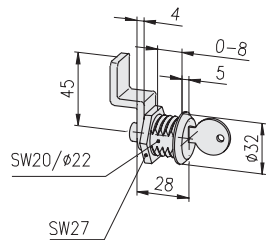

**Technical data**

capsule: GD Zn, galvanised  
tongue, nut, screw: steel, galvanised

Description	Weight	Article-No.
Cylinder lock with 2 keys, without security latch	66 g	1.65.3201

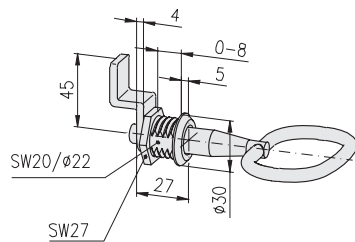

**Comments**

Socket wrench / square 8 mm

Description	Weight	Article-No.
Cylinder lock with 1 square key, without security latch	100 g	1.65.3202

**Security latch**

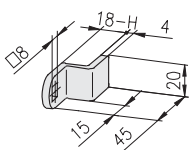

Description	Weight	Article-No.
Security latch for cylinder lock	30 g	1.65.32...

H	Article-No.	H	Article-No.	H	Article-No.	H	Article-No.
4	1.65.3204	18	1.65.3218	30	1.65.3230	42	1.65.3242
6	1.65.3206	20	1.65.3220	32	1.65.3232	44	1.65.3244
8	1.65.3208	22	1.65.3222	34	1.65.3234	45	1.65.3245
10	1.65.3210	24	1.65.3224	35	1.65.3235	47	1.65.3247
13	1.65.3213	25	1.65.3225	36	1.65.3236	50	1.65.3250
14	1.65.3214	26	1.65.3226	38	1.65.3238		
16	1.65.3216	28	1.65.3228	40	1.65.3240		

**Flap-lock countersunk for sliding door**

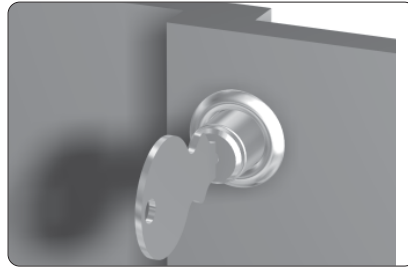

**Application**

Lock for sliding door

**Technical data**

capsule: GD Zn, chrome-plated  
tongue and nut: steel, galvanised

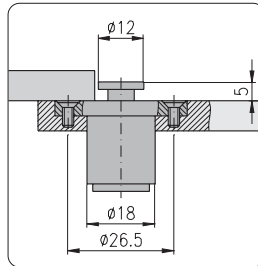
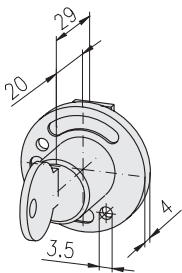

Locked

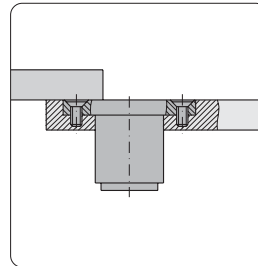

Open

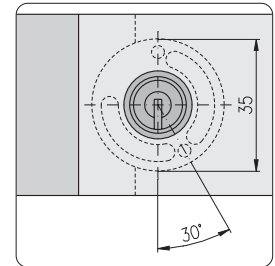

**Description**

Flap-lock countersunk, for sliding door

**Weight**

52 g

**Article-No.**

1.65.3301

**Cylinder locks flush**



**Application**

Locking system for swinging doors

**Technical data**

locking:  $90^\circ$   
material:  
• capsule: GD Zn, chrome-plated  
• fixing plate: steel, chrome-plated

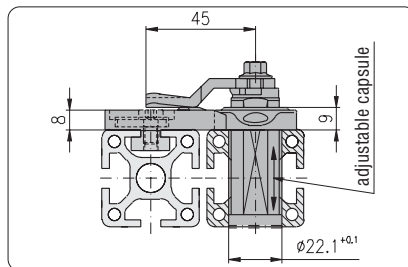

Outside: flush  
(without jutout of lock parts)

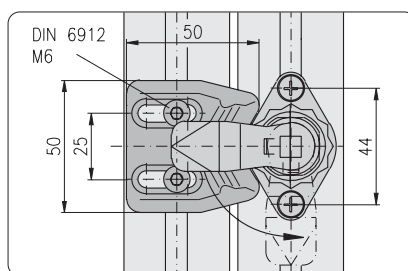
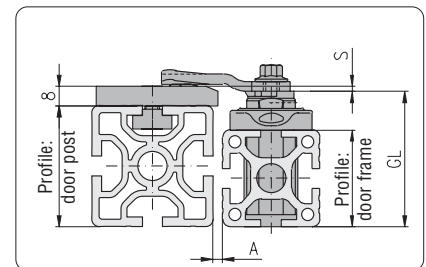

Inside: with fixing plate

Profile		Latch		
Door post	Door frame	GL	A	S
40	40	56	1.6	-8
	45	66	1.8	-12
50	40	56	1.6	2
	45	66	1.8	-8
	50	66	2.0	-8
60	40	56	1.6	12
	45	66	1.8	2
	50	66	2.0	2
	60	76	3.0	-8

**Cylinder locks flush**

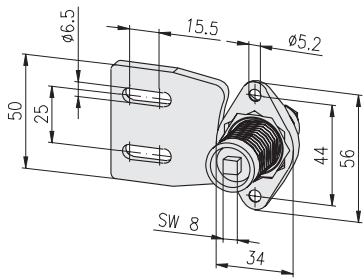

**Delivery unit**

- cylinder lock with fixing plate

**Separate order**

- key
- security latch

Description	GL	Weight	Article-No.
Cylinder lock flush, square	56	194.0 g	1.65.34156
Cylinder lock flush, square	66	212.8 g	1.65.34166
Cylinder lock flush, square	76	231.6 g	1.65.34176

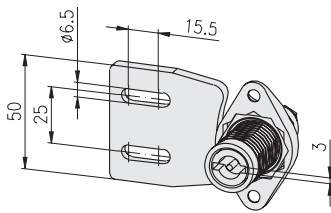

**Delivery unit**

- cylinder lock with fixing plate

**Separate order**

- key
- security latch

Description	GL	Weight	Article-No.
Cylinder lock flush, double beard	56	193.8 g	1.65.34356
Cylinder lock flush, double beard	66	204.1 g	1.65.34366
Cylinder lock flush, double beard	76	214.4 g	1.65.34376

**Square keys**

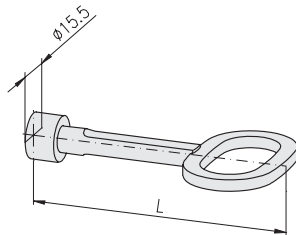

Description	L	Material	Weight	Article-No.
Square key 8, 40 mm		PA-GF	7.5 g	1.65.34540
Square key 8, 81 mm		GD Zn	41.6 g	1.65.34581

**Double beard keys**

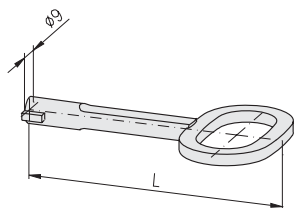

Description	L	Material	Weight	Article-No.
Double beard key 3, 40 mm		PA-GF	6.4 g	1.65.34740
Double beard key 3, 89 mm		GD Zn	35.8 g	1.65.34789

**Security latches**

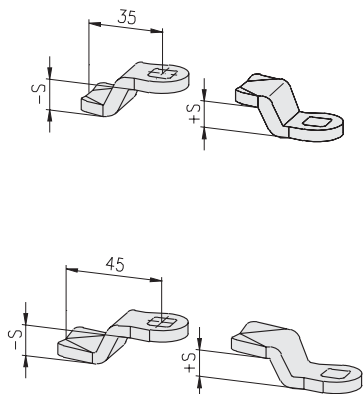

Description	S	Weight	Article-No.
Security latch 35	2	20.4 g	1.65.3493502.1
Security latch 35	-2	20.1 g	1.65.3493502.2
Security latch 35	-8	22.5 g	1.65.3493508.2
Security latch 35	12	22.9 g	1.65.3493512.1
Security latch 35	-12	22.9 g	1.65.3493512.2

Description	S	Weight	Article-No.
Security latch 45	2	26.8 g	1.65.3494502.1
Security latch 45	-2	27.4 g	1.65.3494502.2
Security latch 45	-8	27.3 g	1.65.3494508.2
Security latch 45	12	30.3 g	1.65.3494512.1
Security latch 45	-12	30.3 g	1.65.3494512.2

**Mortise deadlocks**



**Application**

Door locks for doors with profile frames made from profiles 40×40 and 45×45

**Technical data**

mortise deadlock: steel, galvanised  
 screws and threaded plates: steel, galvanised  
 lock insert: GD-Zn, galvanised  
 rosette: LM, neutral anodised  
 case: Al Mg Si 0.5 F25, neutral anodised



Door lock without lock insert and handles both sides



Door lock with cylinder lock and handles both sides



Door lock with lock insert, one handle and one fixed knob

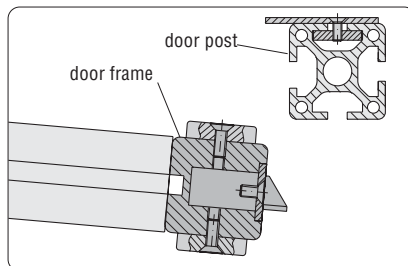

Mounting position left

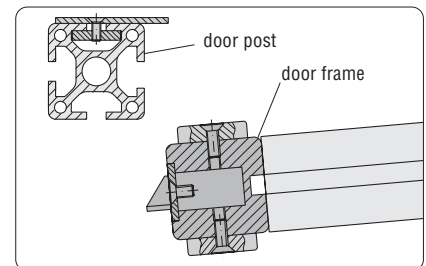

Mounting position right

**Profile machining**  
for door post

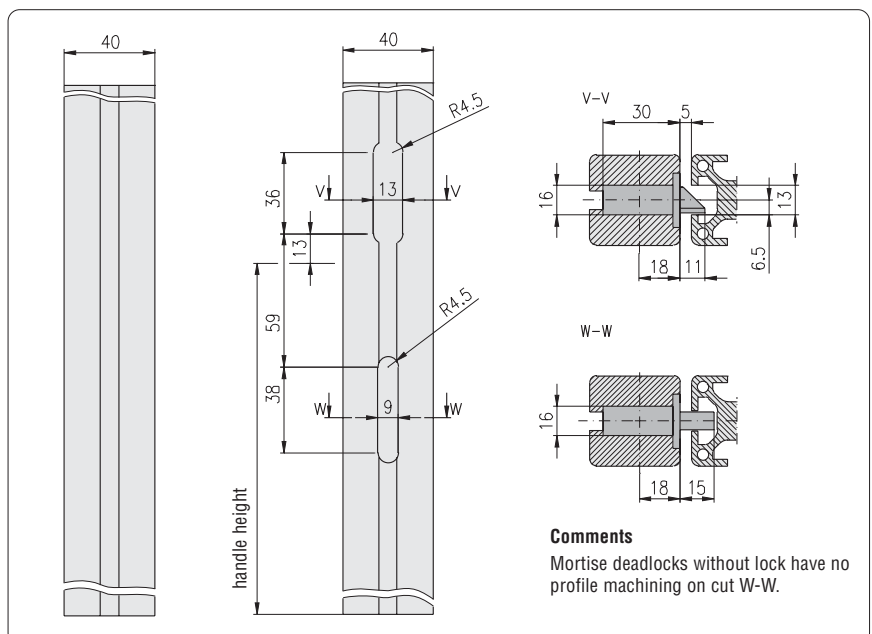

**Comments**

Mortise deadlocks without lock have no profile machining on cut W-W.



**Mortise deadlock installation sets**  
without lock

**Comments**

Drawing shows mounting position left,  
mirror image mounting position right

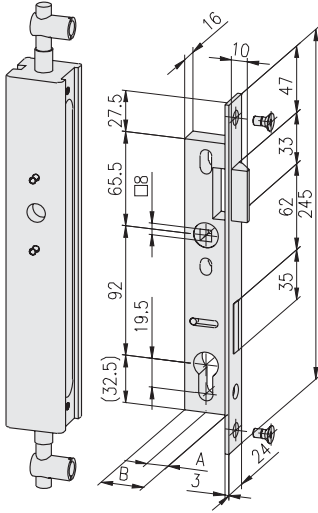

Description	Weight	Article-No.
Mortise deadlock installation set without lock, left, PG 40	1,191 g	1.65.4001L40
Mortise deadlock installation set without lock, right, PG 40	1,191 g	1.65.4001R40
Mortise deadlock installation set without lock, left, PG 45	1,352 g	1.65.4001L45
Mortise deadlock installation set without lock, right, PG 45	1,352 g	1.65.4001R45

**Single parts**

Description	Pcs.	Weight	Article-No.
Mortise deadlock case without lock PG 40	1	665 g	1.65.4101x40
Mortise deadlock case without lock PG 45	1	790 g	1.65.4101x45
Mortise deadlock left, PG 40	1	412 g	1.65.4211L40
Mortise deadlock right, PG 40	1	412 g	1.65.4211R40
Mortise deadlock left, PG 45	1	430 g	1.65.4211L45
Mortise deadlock right, PG 45	1	430 g	1.65.4211R45
Screw connector PG 40	2	55 g	1.21.4S1M8/11
Screw connector PG 45	2	64 g	1.21.4S1M8/11
Countersunk screw DIN 7991 - M5x12	2	2 g	0.63.D07991.05012

**Mortise deadlock cases**  
without lock

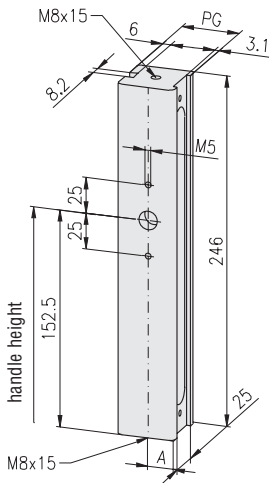

Description	A	B	Weight	Article-No.
Mortise deadlock case without lock				
mounting position le/ri, PG 40	18	30	665 g	1.65.4101x40
mounting position le/ri, PG 45	20	32	790 g	1.65.4101x45

**Mortise deadlock installation sets**  
with lock

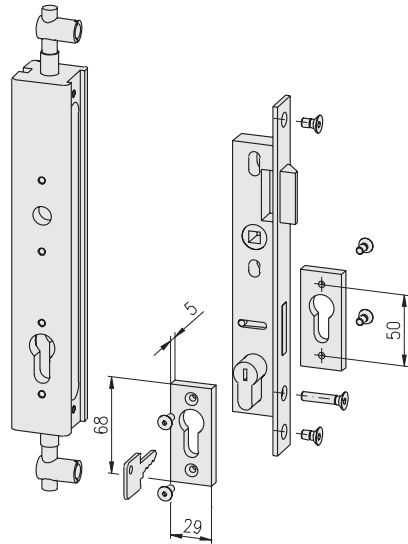

Dimensions → 263, drawing „Mortise deadlock installation sets without lock“

**Comments**

Drawing shows mounting position left, mirror image mounting position right

Description	Weight	Article-No.
Mortise deadlock installation set with lock, left, PG 40	1,371 g	1.65.4002L40
Mortise deadlock installation set with lock, right, PG 40	1,371 g	1.65.4002R40
Mortise deadlock installation set with lock, left, PG 45	1,535 g	1.65.4002L45
Mortise deadlock installation set with lock, right, PG 45	1,535 g	1.65.4002R45

**Single parts**

Description	Pcs.	Weight	Article-No.
Mortise deadlock case with lock PG 40	1	620 g	1.65.4102x40
Mortise deadlock case with lock PG 45	1	740 g	1.65.4102x45
Mortise deadlock left, PG 40	1	412 g	1.65.4211L40
Mortise deadlock right, PG 40	1	412 g	1.65.4211R40
Mortise deadlock left, PG 45	1	430 g	1.65.4211L45
Mortise deadlock right, PG 45	1	430 g	1.65.4211R45
Screw connector PG 40	2	55 g	1.21.4S1M8/11
Screw connector PG 45	2	64 g	1.21.4S1M8/11
Lock insert with 2 keys, PG 40	1	188 g	1.65.421240
Lock insert with 2 keys, PG 45	1	196 g	1.65.421245
Countersunk screw DIN 7991 - M5x12	2	2 g	0.63.D07991.05012
Rosette, set	1	25 g	1.65.4213
Countersunk screw DIN 7991 - M5x14	4	2 g	0.63.D07991.05014
Countersunk screw DIN 7991 - M5x30	1	4 g	0.63.D07991.05030

**Mortise deadlock cases**  
with lock

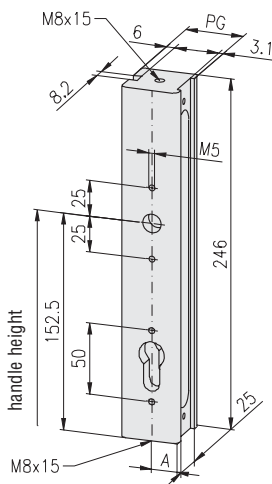

Description	A	B	Weight	Article-No.
Mortise deadlock case with lock				
mounting position L/R, PG 40	18	30	620 g	1.65.4102x40
mounting position L/R, PG 45	20	32	740 g	1.65.4102x45

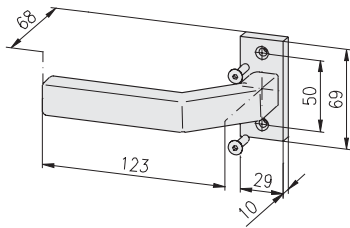
**Door handle**

**Technical data**

material: LM  
surface: neutral anodised

Description	Weight	Article-No.
Door handle set	166 g	1.65.4220

**Single parts**

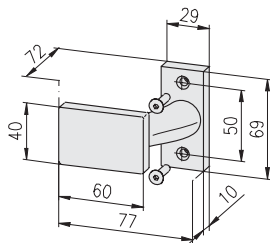
Description	Pcs.	Weight	Article-No.
Handle with rosette	1	160 g	1.65.4221
Countersunk screw DIN 7991 - M5x20	2	3 g	0.63.D07991.05020

**Door knob**

**Technical data**

material: LM  
surface: neutral anodised

**Comments**

Door knob fixed

Description	Weight	Article-No.
Door knob set	178 g	1.65.4230

**Single parts**

Description	Pcs.	Weight	Article-No.
Door knob with rosette	1	172 g	1.65.4231
Countersunk screw DIN 7991 - M5x20	2	3 g	0.63.D07991.05020

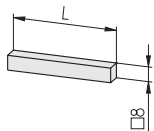
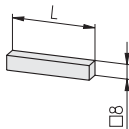
**Push pins**

**Technical data**

material: steel  
surface: galvanised

**Comments**

Stop pin for 1 door handle variant only

Description	L	Weight	Article-No.
Push pin for 1 door handle, PG 40	56	28 g	1.65.425140
Push pin for 1 door handle, PG 45	58.5	29 g	1.65.425145

Description	L	Weight	Article-No.
Push pin for 2 door handles, PG 40	94	54 g	1.65.425240
Push pin for 2 door handles, PG 45	99	57 g	1.65.425245

Bar locks



Bar lock with olive

**Application**

Lock for large doors made of profile 30×60 or 40×80, with pin arrest on top and bottom side



Bar lock with socket wrench

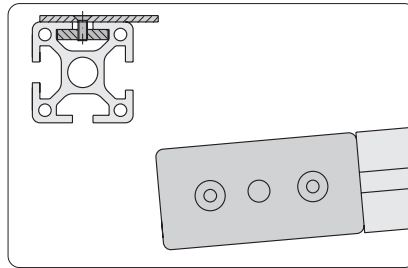

Mounting position right

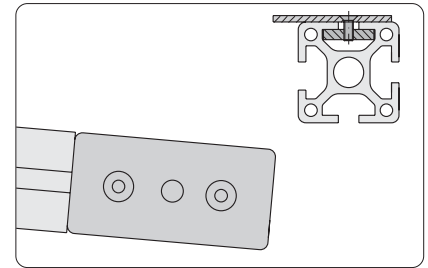

Mounting position left

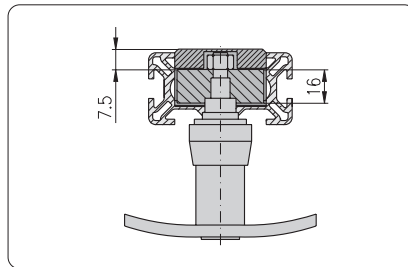

Mounting in profile 30×60

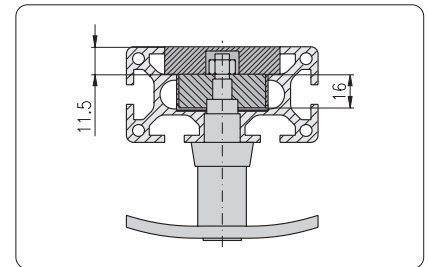

Mounting in profile 40×80

**Profile machining 30x60**  
for bar lock

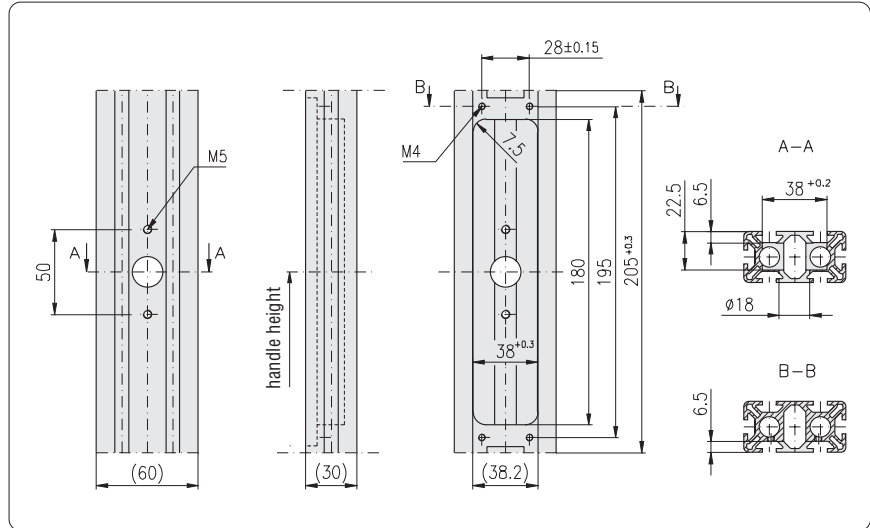
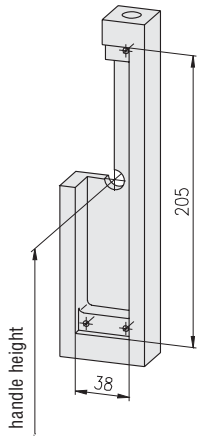

**Description**

Profile machining 30x60 for bar lock

**Article-No.**

1.65.5110

**Profile machining 40x80**  
for bar lock

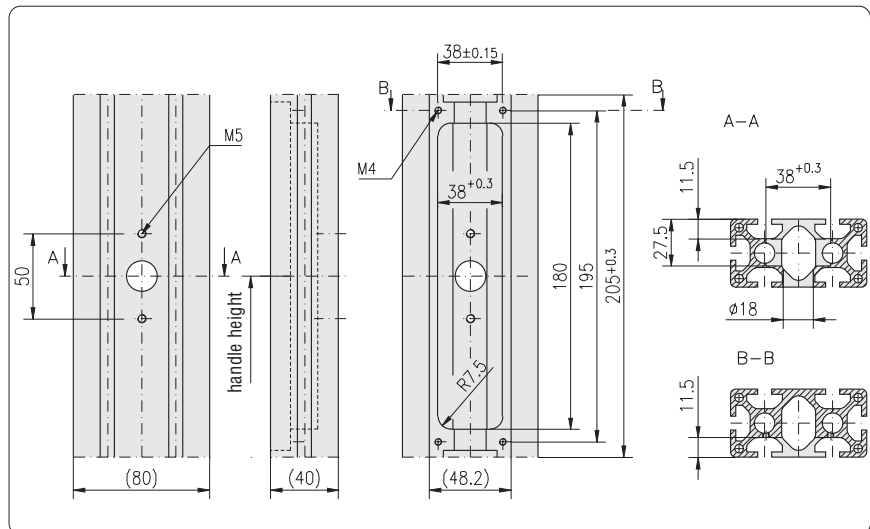
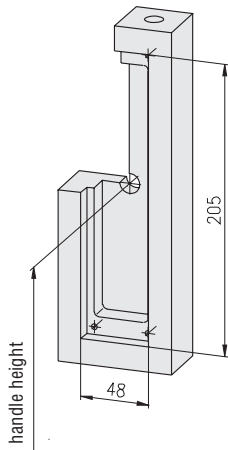

**Description**

Profile machining 40x80 for bar lock

**Article-No.**

1.65.5120

**Bar locks**

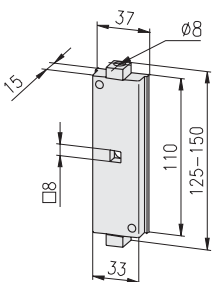

**Technical data**

material: steel  
surface: galvanised

**Description**

Bar lock, left side

Bar lock, right side

**Weight**

230 g

230 g

**Article-No.**

1.65.5210L

1.65.5210R

**Bar locks**
**Technical data**

cover plate: alu, neutral anodised  
 face plate: alu, neutral anodised  
 bar: steel, galvanised  
 screws: steel, galvanised

**Assembly accessories 30×60**

for bar lock

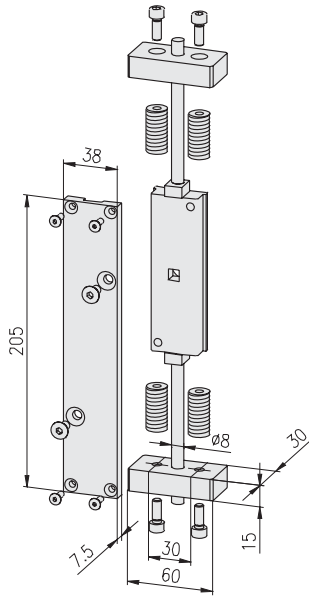

Description	Weight	Article-No.
Assembly accessories 30×60 for bar lock	590 g	1.65.5310

**Single parts**

Description	Pcs.	Weight	Article-No.
Cover plate 30×60	1	100 g	1.65.5311
Countersunk screw DIN 7991 - M4×12	4	1 g	0.63.D07991.04012
Countersunk screw DIN 7991 - M6×12	2	3 g	0.63.D07991.06012
Front plate 30×60	2	50 g	1.65.5312
Threaded insert M14/M6	4	22 g	1.35.1140615
Cap-screw DIN 912 - M6×16	4	5 g	0.63.D00912.06016
Bar, L1000	2	136 g	1.65.5313

**Assembly accessories 40×80**

for bar lock

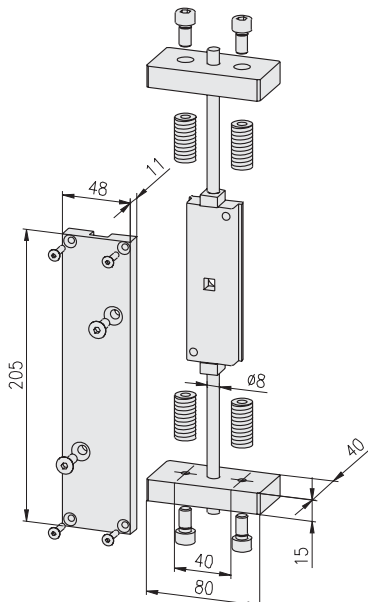

Description	Weight	Article-No.
Assembly accessories 40×80 for bar lock	800 g	1.65.5320

**Single parts**

Description	Pcs.	Weight	Article-No.
Cover plate 40×80	1	225 g	1.65.5321
Countersunk screw DIN 7991 - M4×16	4	2 g	0.63.D07991.04016
Countersunk screw DIN 7991 - M6×16	2	4 g	0.63.D07991.06016
Front plate 40×80	2	90 g	1.65.5322
Threaded insert M14/M8	4	18 g	1.35.1140815
Cap-screw DIN 912 - M8×16	4	9 g	0.63.D00912.08016
Bar, L1000	2	136 g	1.65.5313

**Olive installation set**

for bar lock

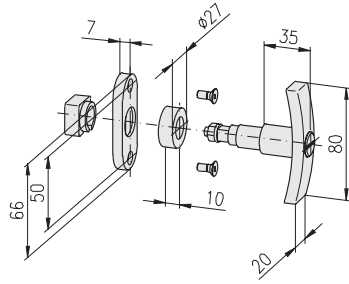
**Technical data**

material: GD-Zn, chrome-plated

**Comments**

Execution for profile 30x60 = with rosette

Execution for profile 40x80 = without rosette

Description	Weight	Article-No.
Olive installation set for bar lock without lock, for profile 30x60	134 g	1.65.5410
for profile 40x80	122 g	1.65.5420
Olive installation set for bar lock with lock, for profile 30x60	134 g	1.65.5510
for profile 40x80	120 g	1.65.5520

**Single parts**

Description	Pcs.	Weight	Article-No.
Olive without lock	1	122 g	1.65.5431
Olive with lock, incl. 2 keys	1	120 g	1.65.5531
Rosette	1	8 g	1.65.5432
Countersunk screw DIN 7991 - M5x12	2	2 g	0.63.D07991.05012

**Lock mounting set**
**with square key**

for bar lock

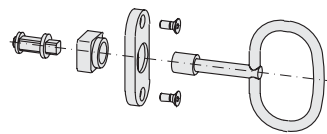
**Technical data**

lock insert: GD-Zn, galvanised

key: GD-Zn, galvanised

rosette: LM, neutral anodised

key catch: PVC, grey

Description	Weight	Article-No.
Lock mounting set with square key for bar lock	73 g	1.65.5600

**Single parts**

Description	Pcs.	Weight	Article-No.
Lock insert	1	16 g	1.65.5601
Key catch	1	3 g	1.65.5602
Rosette	1	8 g	1.65.5432
Square key 8 mm	1	42 g	1.65.5604
Countersunk screw DIN 7991 - M5x12	2	2 g	0.63.D07991.05012

**with double beard key**

for bar lock

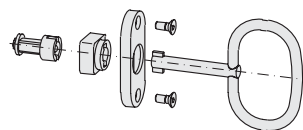

Description	Weight	Article-No.
Lock mounting set with double beard key for bar lock	73 g	1.65.5700

**Single parts**

Description	Pcs.	Weight	Article-No.
Lock insert	1	16 g	1.65.5701
Key catch	1	3 g	1.65.5702
Rosette	1	8 g	1.65.5432
Double beard key Ø5	1	42 g	1.65.5704
Countersunk screw DIN 7991 - M5x12	2	2 g	0.63.D07991.05012

**Latch locks**



**Application**

Door lock with small jutout

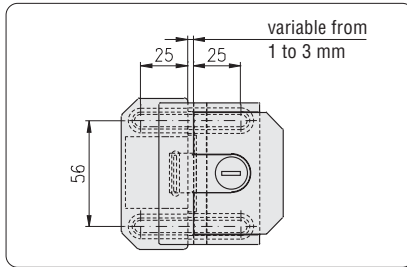

Installation dimensions

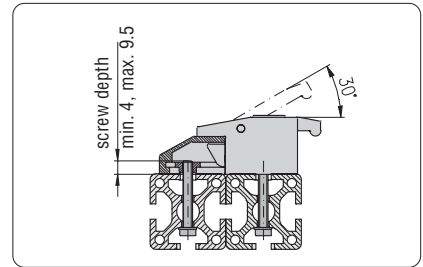

Installation dimensions

**Technical data**

material:

- capsule: GDZn black coated
- trap: GDZn rough
- nut: steel galvanised

**Mounting elements**

- cap-screw DIN 6913, M6
- washer DIN 433-6.4

**Delivery unit**

- latch lock
- 4 nuts M6
- 2 keys (by variant with lock)
- cover plug (by variant without lock)

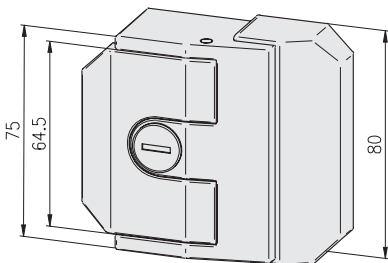

**Description**

Description	Weight	Article-No.
Latch lock without lock	560 g	1.65.6010
Latch lock with lock, all keyed alike	560 g	1.65.6020
Latch lock with lock, keyed different	560 g	1.65.6030



**Roller 39.5**

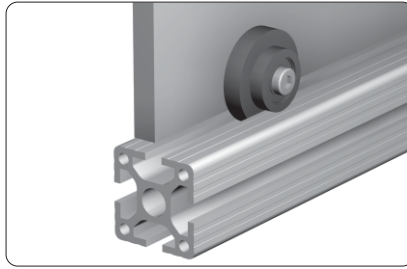

**Application**

Roller for guiding in the 8 mm profile slot for sliding doors

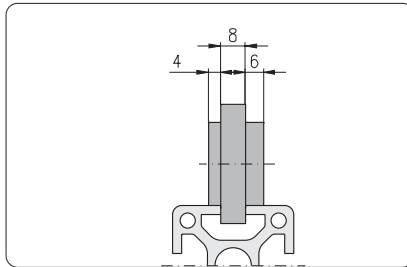

Asymmetric mount

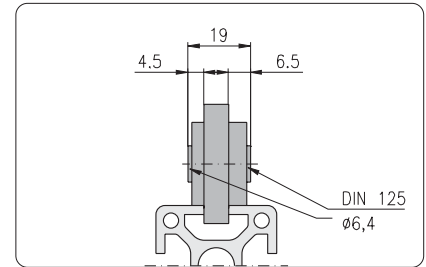

Mounting measure incl. washer DIN 125

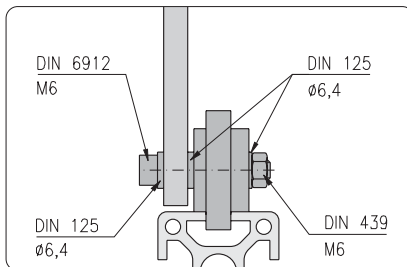

Mounting with threaded pillar

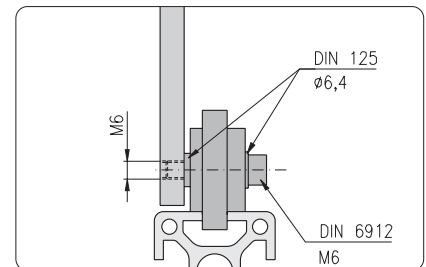

Mounting with thread in panel element

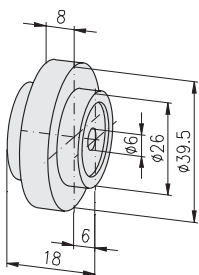
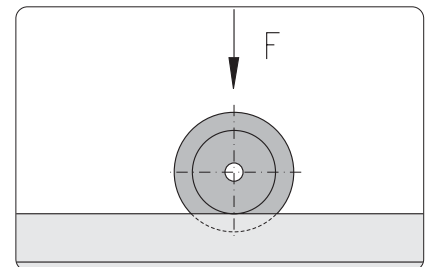

**Technical data**

material: PA-GF  
 colour: black  
 max. static load: F = 150 N

**Comments**

2 deep grooved ball bearings with 2 cover discs

**Description**

Roller 39.5

**Weight**

32 g

**Article-No.**

1.66.1395



**Roller fastening sets type A**



Roller fastening set type A, one-sided

**Application**

The roller fastening set allows the mounting of the roller into the panel element. Thus the panel element fits in the slot and fills the frame completely

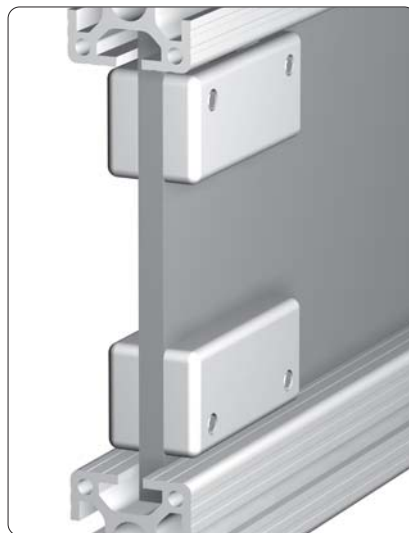

Roller fastening set type A, double-sided

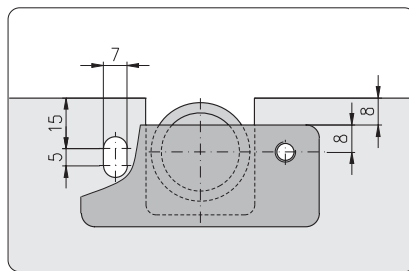

Mounting on top side

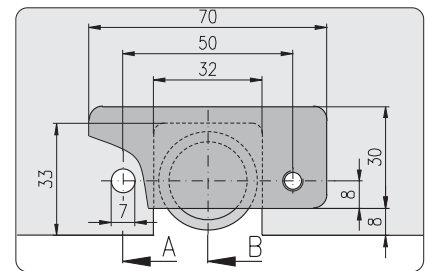

Mounting on bottom side

**Comments**

The elongated hole in the panel element allows the adjustment of the height tolerance

Roller fastening sets  
type A

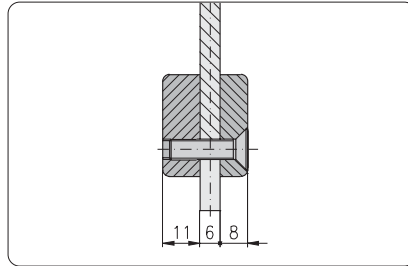

Panel element 6 mm  
View A - A

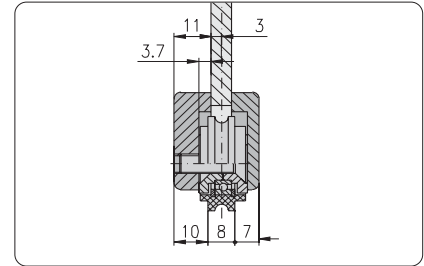

Panel element 6 mm  
View B - B

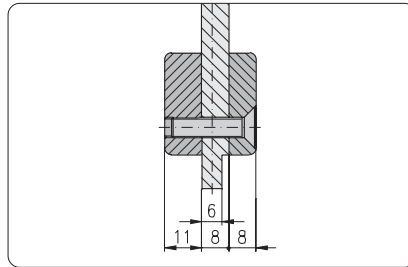

Panel element 8 mm  
View A - A

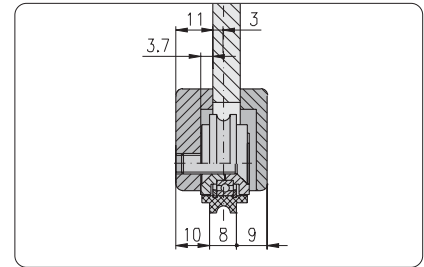

Panel element 8 mm  
View B - B

**Technical data**

base body  
material: aluminium  
surface: neutral anodised

**one sided**

Description	Weight	Article-No.
Roller fastening set type A, one sided, complete	55.5 g	1.66.5160

**Single parts**



Description	Pcs.	Weight	Article-No.
Roller bracket type A, left	1	21.0 g	1.66.5299
Roller 29	1	12.0 g	1.66.2290
Countersunk screw DIN 7991 - M6x20	1	4.5 g	0.63.D07991.06020
Cap-screw DIN 6912 - M6x20	2	5.0 g	0.63.D06912.06020
Washer DIN 6340 - 6.4	2	4.0 g	0.62.D06340.A06,4

**double sided**

Description	Weight	Article-No.
Roller fastening set type A, double sided, complete	64.5 g	1.66.5260

**Single parts**



Description	Pcs.	Weight	Article-No.
Roller bracket type A, right	1	16.0 g	1.66.5298
Roller bracket type A, left	1	21.0 g	1.66.5299
Roller 29	1	12.0 g	1.66.2290
Countersunk screw DIN 7991 - M6x20	1	4.5 g	0.63.D07991.06020
Countersunk screw DIN 7991 - M6x25	2	5.5 g	0.63.D07991.06025

**Roller fastening sets type B**



Guidance in profile slot

**Application**

The roller fastening set allows the mounting of the roller into the panel element

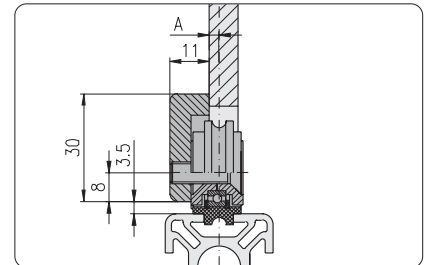

Guidance in twin track guide

**Comments**

Mounting position of roller optional

A = 1.7 mm  
2.7 mm

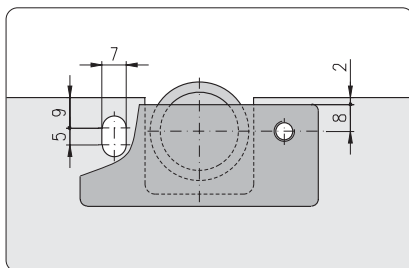

Mounting on top side

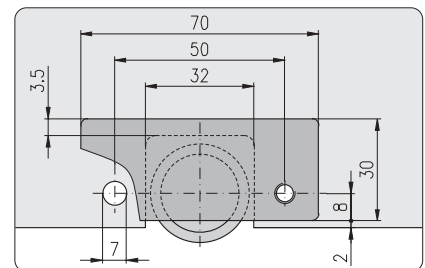

Mounting on bottom side

**Comments**

The elongated hole in the panel element allows to adjust the height tolerance and to unhinge the sliding door

**Roller fastening sets type B**



**Application**

Guidance of sliding door  
 on top: sliding profile 30x14  
 on bottom: twin track guide with profile

The slot in the panel element allows:

- adjustment of height tolerance
- removal of the sliding door

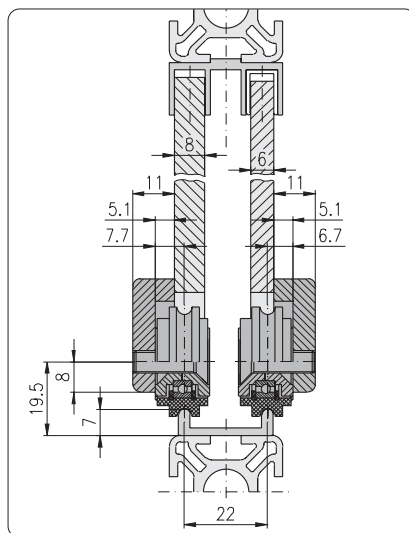

Mounting position of roller:  
 dimension 6.7 = panel element 6 mm  
 dimension 7.7 = panel element 8 mm

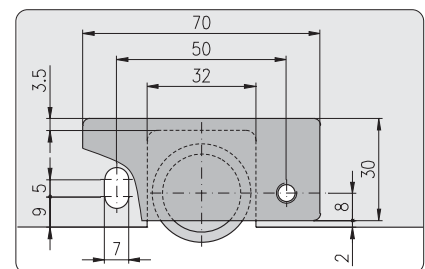

**Technical data**

base body  
 material: aluminium  
 surface: neutral anodised

Description	Weight	Article-No.
Roller fastening set type B, complete	62 g	1.66.5360



**Single parts**

Description	Pcs.	Weight	Article-No.
Roller bracket type B	1	21.0 g	1.66.5399
Roller 29	1	12.0 g	1.66.2290
Countersunk screw DIN 7991 - M6x20	1	4.5 g	0.63.D07991.06020
Cap-screw DIN 6912 - M6x20	2	5.0 g	0.63.D06912.06020
Washer DIN 6340 - 6.4	2	4.0 g	0.62.D06340.A06,4

**Mounting adaptor for roller**



**Application**  
For fastening of rollers

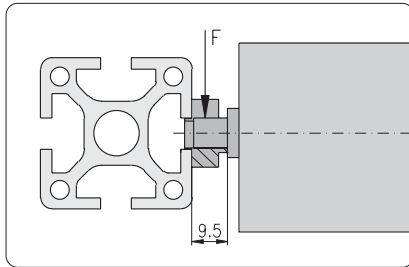

**Comments**  
Simple mounting, enables installation without dismounting of frame  
 $F_{max} = 1.000 \text{ N}$

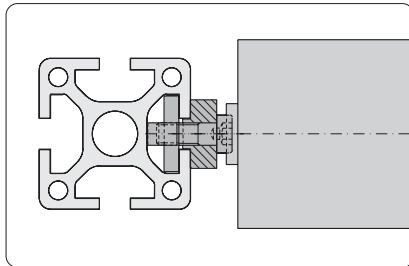

**Technical data**  
material: PA, black

**Mounting elements**  
F-slot: threaded plate F M6                    1.31.FM6  
E-slot: threaded plate E M6                    1.31.EM6  
          threaded plate, heavy E M6        1.316.EM6  
cap-screw DIN 6912, M6

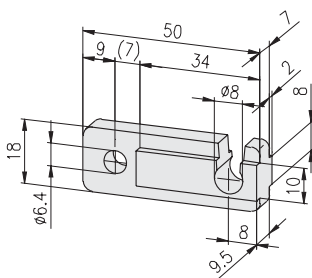

Description	Weight	Article-No.
Mounting adaptor for roller Ø8	9 g	1.66.70808

**Edge roller**



**Application**

Roller conveyors for transporting boxes and containers

- low noise
- low friction operation due to double ball bearings
- simple assembly

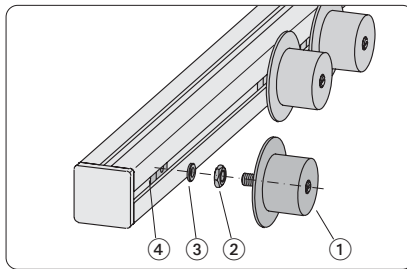

**Single parts**

- ① edge roller
- ② hexagon nut
- ③ shim
- ④ threaded plate

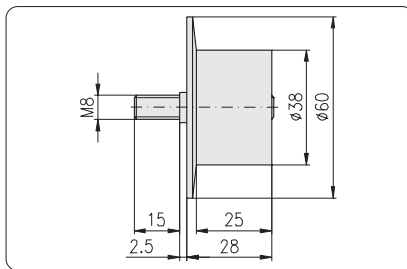

**Technical data**

material:

- roller: impact resistant plastic
- axle: galvanised

colour:

- roller: black

bearings: steel or stainlessball bearings on galvanised steel bolt

loading capacity:

- static: 50 N
- dynamic: 100 N

**Mounting elements**

threaded plate E M8	1.31.EM8
hexagon nut DIN 934 - M8	0.61.D00934.M08
washer DIN 125 - 8.4	0.62.D00125.A08,4

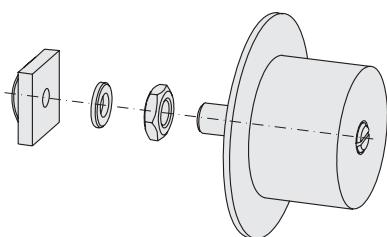

**Description**

Edge roller E

**Weight**

51.0 g

**Article-No.**

1.66.7523860



**Roller fitting  
for suspended doors**

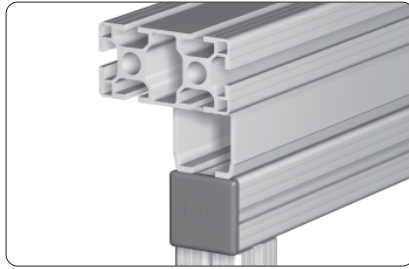

**Application**

Sliding suspended doors made of profile frames for large openings and heavy doors

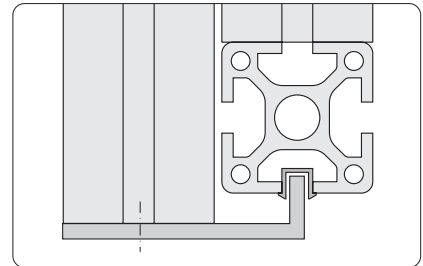
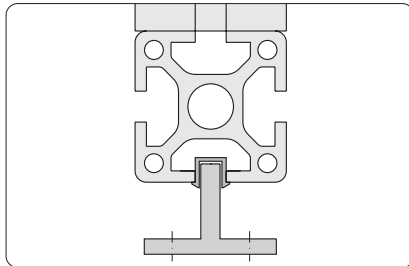
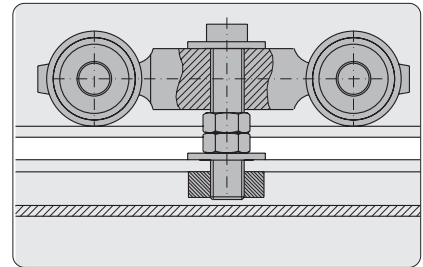
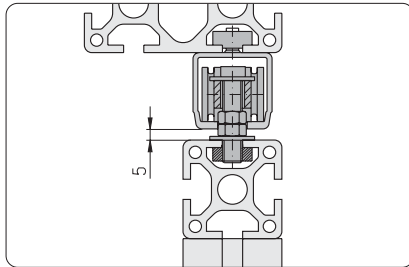

Guidance for mounting on the floor

Guidance for mounting on the profile frame

**Alu C-track  
for suspended doors**

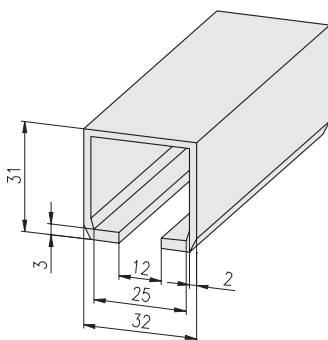

**Technical data**

bar length: 6 m  
material: aluminium  
surface: neutral anodised

**Description**

Description	Weight	Article-No.
Alu C-track bar	3.6 kg	1.19.14532.60
Alu C-track cut to length	0.6 kg	1.19.14532-A00A00/... /... = length in mm

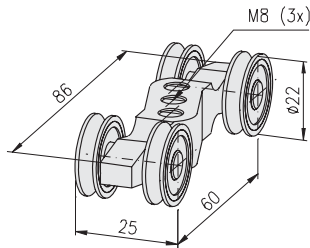
**Runner**  
for suspended door

**Technical data**

material: steel  
 surface: galvanised  
 4 ball bearing rollers  
 max. load capacity: 70 kg

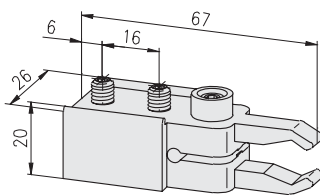
Description	Weight	Article-No.
Runner for suspended door	91 g	1.66.8020

**Stopper**  
for suspended door

**Technical data**

material: plastic  
 colour: grey

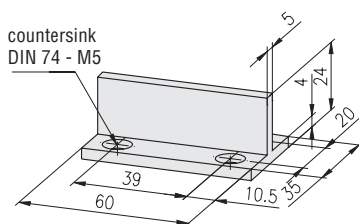
Description	Weight	Article-No.
Stopper for suspended door	21 g	1.66.8030

**Bottom guide**  
for suspended door

**Technical data**

material: plastic  
 colour: grey

**Comments**

Countersink DIN 74 - M5 for  
 countersunk screw DIN 7991 - M5

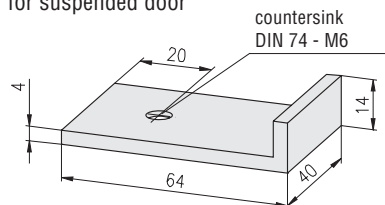
Description	Weight	Article-No.
Bottom guide for suspended door	9 g	1.66.8040

**Frame guide**  
for suspended door

**Technical data**

material: aluminium  
 surface: neutral anodised

**Comments**

Countersink DIN 74 - M6 for  
 countersunk screw DIN 7991 - M6

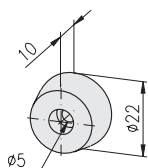
Description	Weight	Article-No.
Frame guide for suspended door	30 g	1.66.8050

**Rubber door stop**  
for suspended door

**Technical data**

material: rubber  
 colour: black

Description	Weight	Article-No.
Rubber door stop for suspended door	3 g	1.66.8060

**Runner  
for sliding suspended doors**



**Application**

Sliding suspended doors made of profile frames for large openings and heavy doors

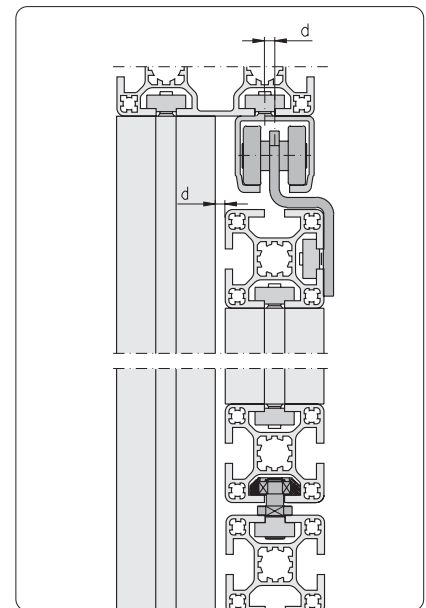
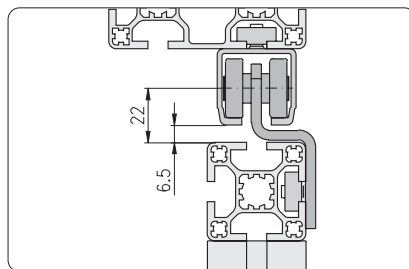
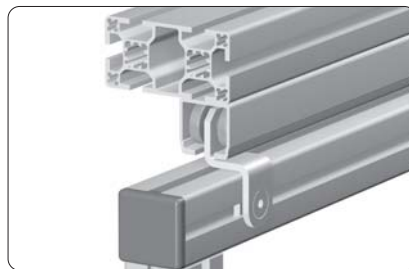

Distance d = mismatch of Alu C-track

**Runner  
for sliding suspended door**

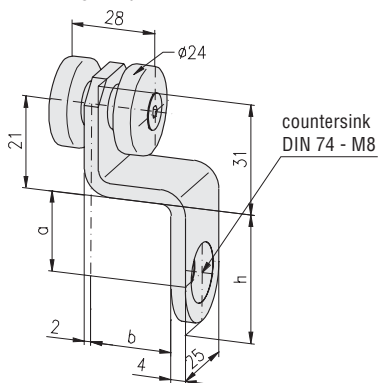

**Technical data**

- material:  
 • strap: VA  
 • bolt: C45 K  
 • distance bush: AlMg3  
 max. load capacity: 100 kg

**Comments**

Countersink DIN 74 - M8 for  
countersunk screw DIN 7991 - M8

**Description**

	<b>a</b>	<b>b</b>	<b>h</b>	<b>Weight</b>	<b>Article-No.</b>
Runner for sliding susp. door, PG 40	21.0	20.0	38.0	102 g	1.66.81140
Runner for sliding susp. door, PG 45	23.5	22.5	43.0	114 g	1.66.81145

**Stopper Type 1**

for sliding suspended door

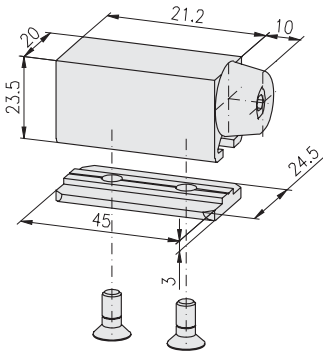
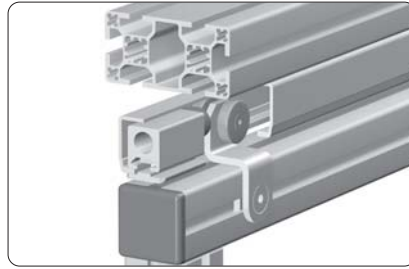
**Description**

Stopper Type 1 for sliding suspended door, complete

**Weight**

63 g

**Article-No.**

1.66.8201055

**Stopper Type 2**

for sliding suspended door

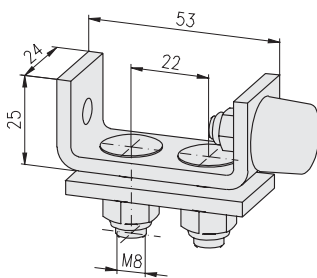
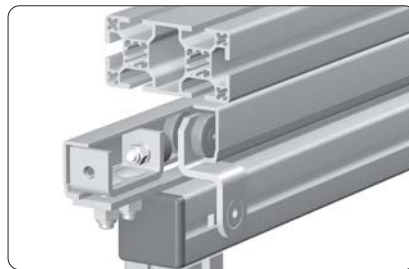
**Description**

Stopper Type 2 for sliding suspended door, complete

**Weight**

160 g

**Article-No.**

1.66.8202065

**Slot rollers**

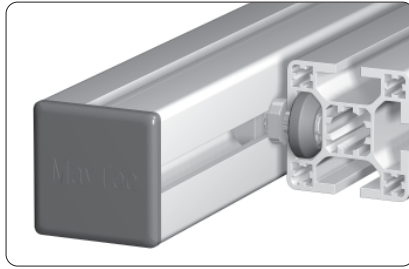

**Application**

For light running sliding doors

**Technical data**

material: PETP  
 colour: black  
 max. static load: 8 kg/roller

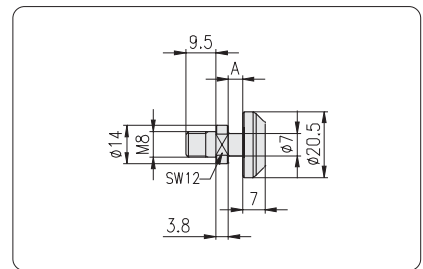
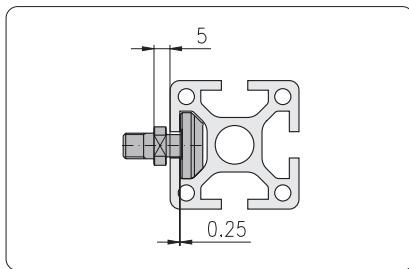
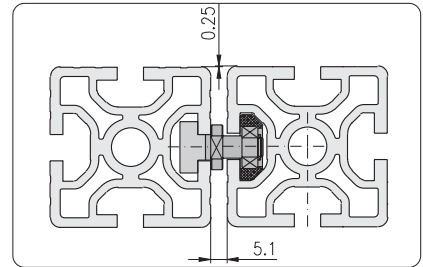
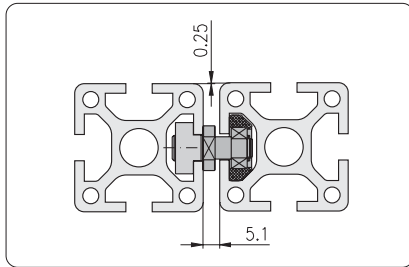

**Fastening elements (optional)**

- threaded plate E M8 1.31.EM8
- threaded plate, heavy, E M8 1.316.EM8
- T-Nut, E M8 1.32.EM8
- T-Nut for subs. insertion E, M8 1.324.EM8

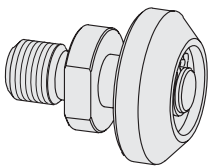

Description	A	Weight	Article-No.
Slot roller E3	4.45	24 g	1.67.42E3M8

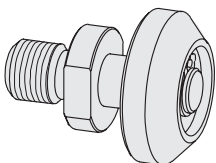

Description	A	Weight	Article-No.
Slot roller E4	5.45	24 g	1.67.42E4M8

**Guidance system**



**Application**

Slideway with sliding blocks e.g. for lifting tables and drawers

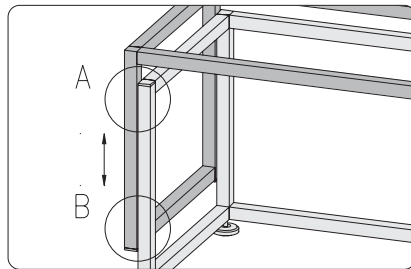

Slideway for lifting table

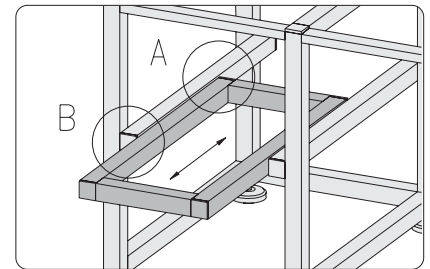

Slideway for drawer

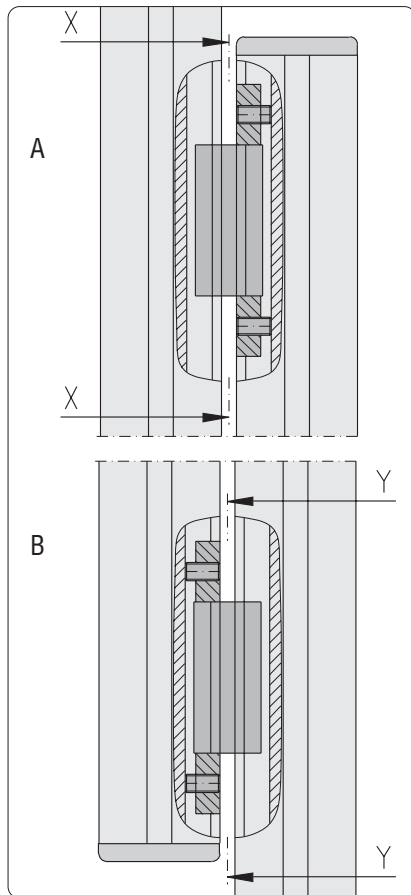

Details "A" and "B"

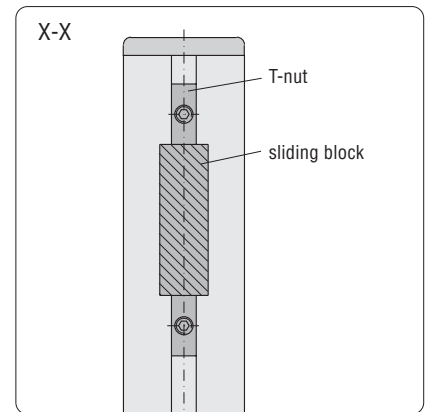

View "X"

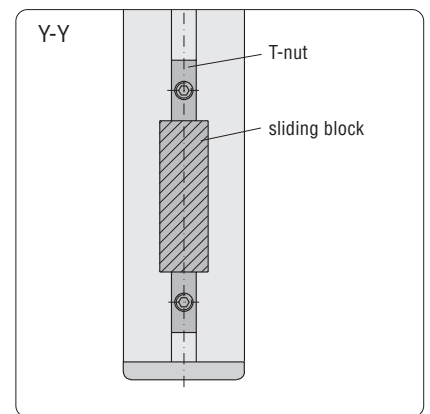

View "Y"

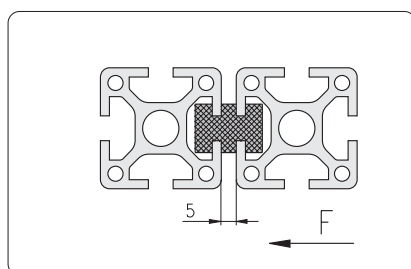

**Clamping**  
for guidance system

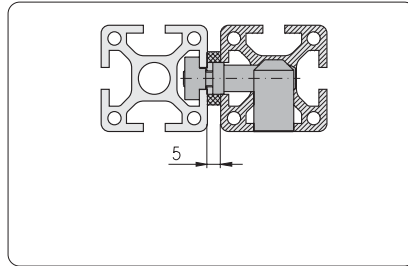

Clamping with setscrew

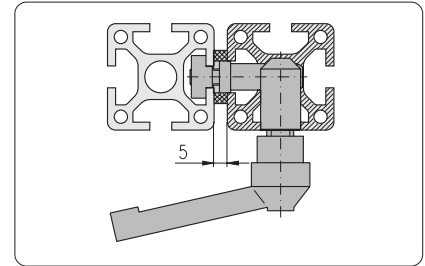

Clamping with clamping lever

**Single parts for clamping**

Description	Article-No.
T-nut sliding block	1.67.□M8
Distance washer	1.67.2008
Clamping lever	1.29.801030

**Connector**

Description	for profile	Article-No.
Connector, screw-type, parallel, M8	30×30	1.21.3/4S5M8/7
Connector, screw-type, parallel, M8	40×40	1.21.4/5S5M8/11
Connector, screw-type, parallel, M8	45×45	1.21.45/5S5M8/11
Connector, screw-type, parallel, M8	50×50	1.21.5/6S5M8/11
Connector, screw-type, parallel, M8	60×60	1.21.6S1M8/11

**Sliding blocks**

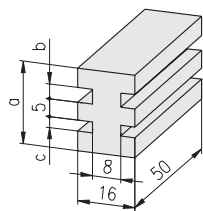
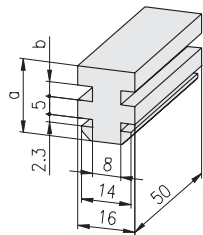
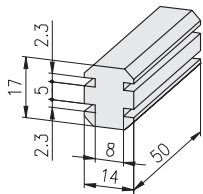

**Technical data**

material: PA, murlubric  
 colour: black  
 max. carrying capacity:  $p = 20 \text{ N/mm}^2$   
 at • temperature 20°C  
 • velocity 1 m/sec

Description	F	Weight	Article-No.
Sliding block F	1,500 N	11 g	1.67.F2F2

Description	a	b	F	Weight	Article-No.
Sliding block F/E3	19.6	3.1	1,500 N	15 g	1.67.F2E3
Sliding block F/E4	20.6	4.1	1,500 N	15 g	1.67.F2E4

Description	a	b	c	F	Weight	Article-No.
Sliding block E3	22.2	3.1	3.1	2,000 N	18 g	1.67.E3E3
Sliding block E3/E4	23.2	3.1	4.1	2,000 N	18 g	1.67.E3E4
Sliding block E4	24.2	4.1	4.1	2,000 N	23 g	1.67.E4E4

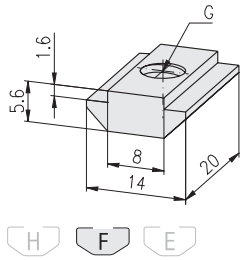
**T-nut sliding blocks**

**Technical data**

material: PA, murlubric  
colour: black

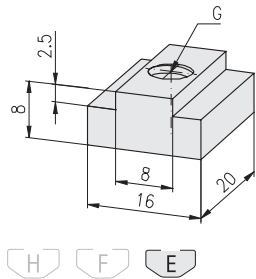
Description	G	Weight	Article-No.
T-nut sliding block F	M6	1.5 g	1.67.FM6
T-nut sliding block F	M8	1.5 g	1.67.FM8

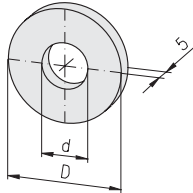

Description	G	Weight	Article-No.
T-nut sliding block E	M6	3 g	1.67.EM6
T-nut sliding block E	M8	3 g	1.67.EM8

**Distance washer**

**Technical data**

material: PVC  
colour: grey

Description	D	d	Weight	Article-No.
Distance washer	22	8.3	3 g	1.67.2002
Distance washer	28	13.0	3 g	1.67.2008

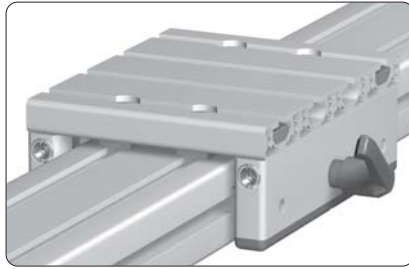

Eco-Slides



**Application**

Sliding carriage in variable, simple and rugged design with low sliding resistance  
High tolerance adjustment for width and height

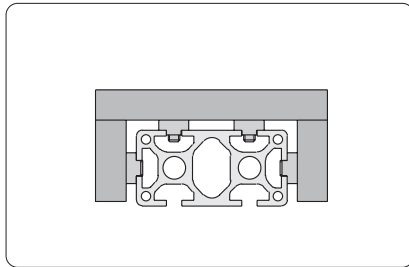

without clamping lever

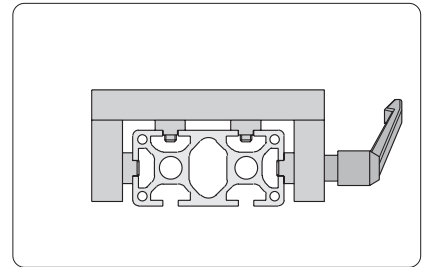

with clamping lever

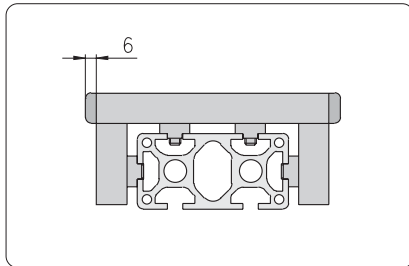

with side cover caps

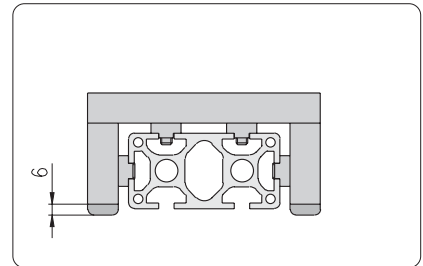

with lower cover caps

**Eco-Slide**

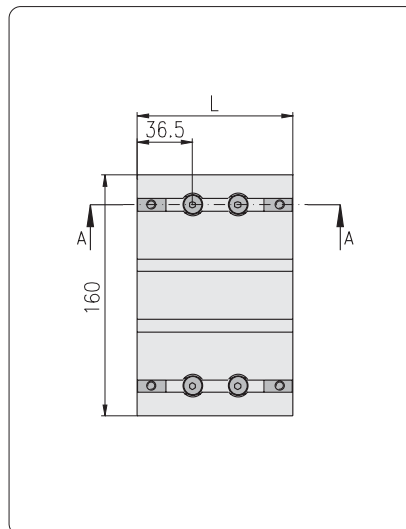
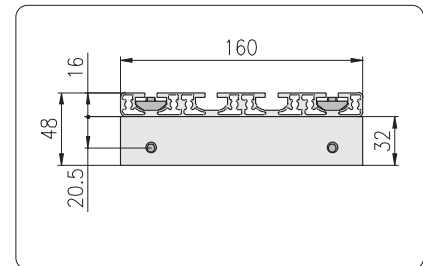
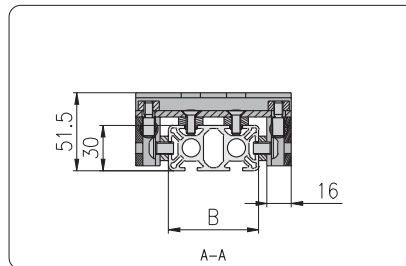
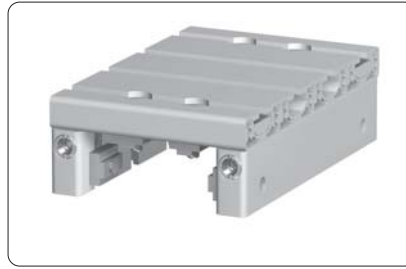
 for profile group 30  
 F-slot

**Width of profile**
**30 mm**

Description	B	L	Weight	Article-No.
Eco-Slide, PG 30 - 30F		73	510 g	1.67.S101.030030F
Eco-Slide, PG 30 - 30F, with clamping lever		73	549 g	1.67.S102.030030F

**60 mm**

Description	B	L	Weight	Article-No.
Eco-Slide, PG 30 - 60F		103	600 g	1.67.S101.030060F
Eco-Slide, PG 30 - 60F, with clamping lever		103	639 g	1.67.S102.030060F

**100 mm**

Description	B	L	Weight	Article-No.
Eco-Slide, PG 30 - 100F		143	720 g	1.67.S101.030100F
Eco-Slide, PG 30 - 100F, with clamping lever		143	759 g	1.67.S102.030100F

**150 mm**

Description	B	L	Weight	Article-No.
Eco-Slide, PG 30 - 150F		193	810 g	1.67.S101.030150F
Eco-Slide, PG 30 - 150F, with clamping lever		193	849 g	1.67.S102.030150F

**Eco-Slide**

for profile group 40  
E-slot

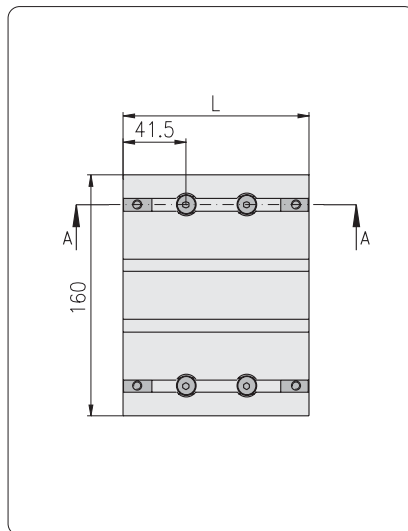
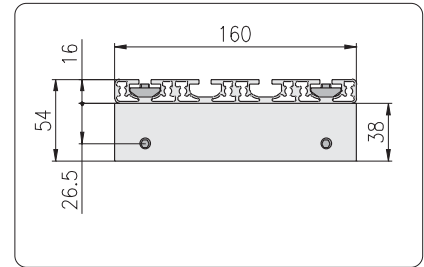
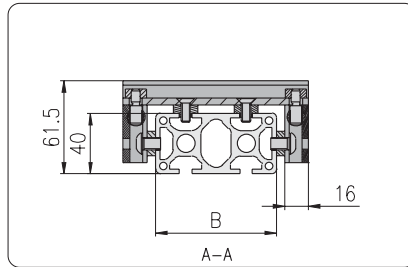
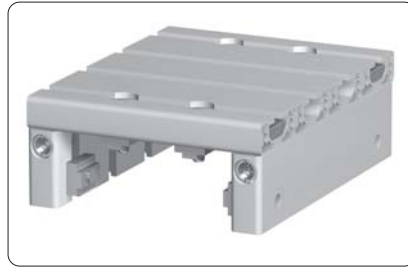

**Width of profile**

**40 mm**

Description	B	L	Weight	Article-No.
Eco-Slide, PG 40 - 40E		83	555 g	1.67.S101.040040E
Eco-Slide, PG 40 - 40E, with clamping lever		83	594 g	1.67.S102.040040E

**80 mm**

Description	B	L	Weight	Article-No.
Eco-Slide, PG 40 - 80E		123	670 g	1.67.S101.040080E
Eco-Slide, PG 40 - 80E, with clamping lever		123	709 g	1.67.S102.040080E

**120 mm**

Description	B	L	Weight	Article-No.
Eco-Slide, PG 40 - 120E		163	790 g	1.67.S101.040120E
Eco-Slide, PG 40 - 120E, with clamping lever		163	829 g	1.67.S102.040120E

**160 mm**

Description	B	L	Weight	Article-No.
Eco-Slide, PG 40 - 160E		203	910 g	1.67.S101.040160E
Eco-Slide, PG 40 - 160E, with clamping lever		203	949 g	1.67.S102.040160E

**Eco-Slide**

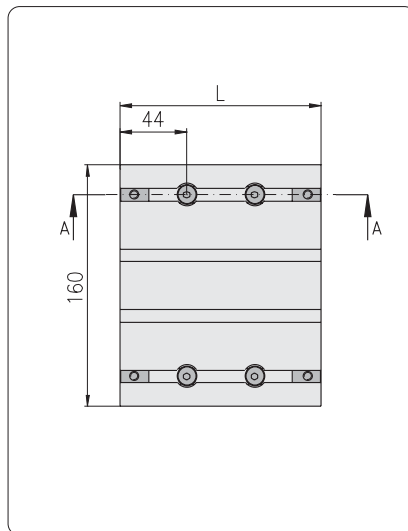
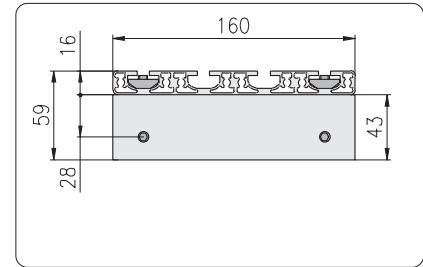
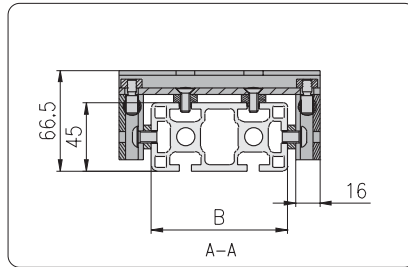
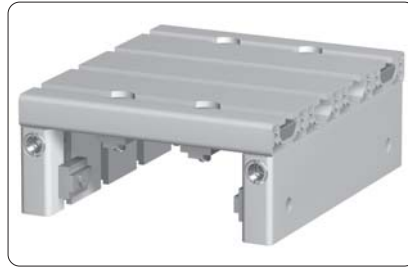
 for profile group 45  
 E-slot

**Width of profile**
**45 mm**

Description	B	L	Weight	Article-No.
Eco-Slide, PG 45 - 45E		88	665 g	1.67.S101.045045E
Eco-Slide, PG 45 - 45E, with clamping lever		88	704 g	1.67.S102.045045E

**90 mm**

Description	B	L	Weight	Article-No.
Eco-Slide, PG 45 - 90E		133	710 g	1.67.S101.045090E
Eco-Slide, PG 45 - 90E, with clamping lever		133	749 g	1.67.S102.045090E

**Hanging bracket**



**Application**

Element for mounting un hingeable fence elements

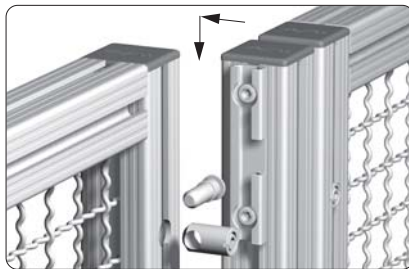

The connector cross bushing can be fixed at the front or back

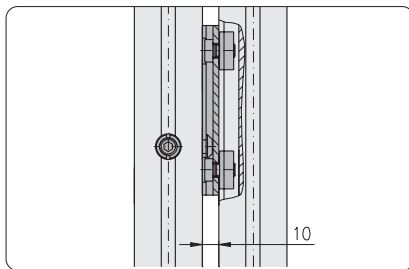

**Technical data**

material: aluminium  
 strength: F25  
 surface: neutral anodised

**Comments**

- Elements needed for mounting:
- cap-screw DIN 6912 M8×12 with threaded plate
  - T-Nut for subsequent insertion M8 with cap-screw DIN 6912 M8×10
  - parallel-connector with F-head

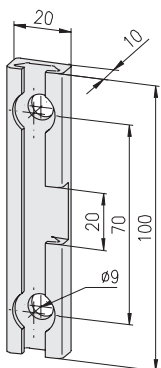

**Description**

Hanging bracket

**Weight**

16 g

**Article-No.**

1.68.201050

**Suspended glider**



**Application**

Element for tool suspension in MayTec-profile

**Technical data**

material: PA-GF  
 colour: black  
 max. static load: 300 N

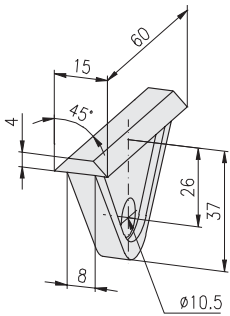

**Description**

Suspended glider F

**Weight**

10 g

**Article-No.**

1.69.F010

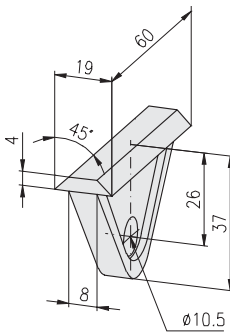

**Description**

Suspended glider E

**Weight**

10 g

**Article-No.**

1.69.E010

**Carabine swivel**

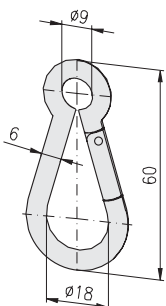

**Technical data**

material: steel  
 surface: galvanised

**Description**

Carabine swivel 60x6

**Weight**

27 g

**Article-No.**

1.69.1606

Potential equalisation



Application

Ground connections to establish the potential equalisation between two profiles  
The serration at the bottom of the socket head of the connector pushes through the anodised coating of the profiles and thus provides the electrical contact

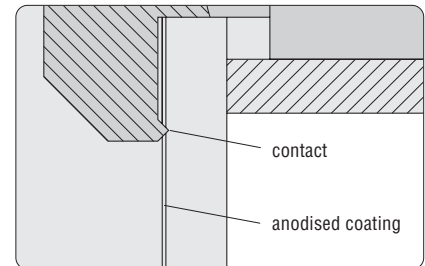
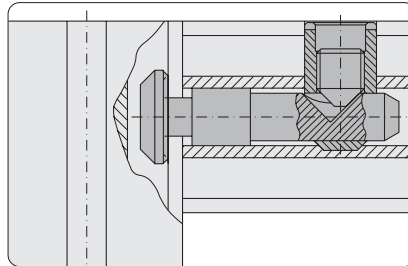

Comments

Suitable to equalise charge accumulations  
Not suitable for higher currents

Technical data

Low current measurements in accordance with DIN VDE 0413, Part 4 for the control of protective circuits, earthing circuits and potential equalisation methods through low resistance connections for protection against dangerous currents

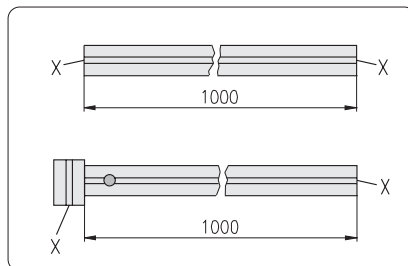

Resistance values with DC current of more than 200 mA with 1.0 m alu-profile

without connector	0.11 Ω
with 1 standard connector	> 2 MΩ
with 1 univ. grounding connector	0.11 Ω

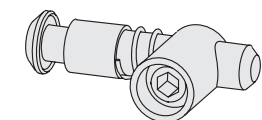

Description

Description	Article-No.
Connector, universal, grounding, PG 20	1.21.2FOE
Connector, universal, grounding, PG 30	1.21.3FOE
Connector, universal, grounding, PG 40	1.21.4FOE
Connector, universal, grounding, PG 45	1.21.45FOE
Connector, universal, grounding, PG 50	1.21.5FOE
Connector, universal, grounding, PG 60	1.21.6FOE

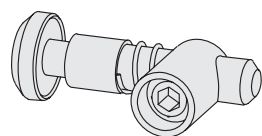

Description

Description	Article-No.
Connector, universal, grounding, PG 20	1.21.2EOE
Connector, universal, grounding, PG 30	1.21.3EOE
Connector, universal, grounding, PG 40	1.21.4EOE
Connector, universal, grounding, PG 45	1.21.45EOE
Connector, universal, grounding, PG 50	1.21.5EOE
Connector, universal, grounding, PG 60	1.21.6EOE

Comments

More grounding connectors  
↪ Connectors 1.2A

**Ground connections**

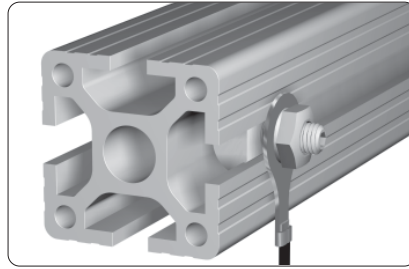

**Application**

Couplings for grounding of anodised profiles

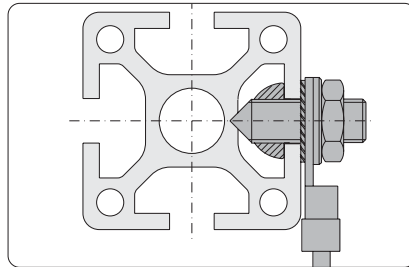

**Comments**

The grounding is caused by breaking the anodised layer at the bottom of the slot and at the profile's front side

Description	Weight	Article-No.
Ground connection F, M6	74 g	1.70.10FM6



**Single parts**

T-Nut for subsequent insertion F, M6
Setscrew DIN 914 - M6×25 - V2A
Fan type lock washer DIN 6798 - A6.4 - V2A
Hexagon nut DIN 439 - M6 - Ms
Washer with chamfer DIN 125 - B6.4 - Ms



Description	Weight	Article-No.
Ground connection E, M8	146 g	1.70.10EM8



**Single parts**

T-Nut for subsequent insertion E, M8
Setscrew DIN 914 - M8×25 - V2A
Fan type lock washer DIN 6798 - A8.4 - V2A
Hexagon nut DIN 439 - M8 - Ms
Washer with chamfer DIN 125 - B8.4 - Ms





**Cable and hose clamp**

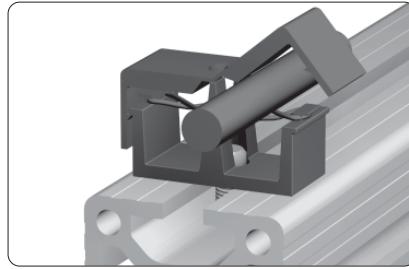

**Application**

Fixing element for cables and hoses up to Ø12 mm

**Technical data**

material: PA  
colour: black

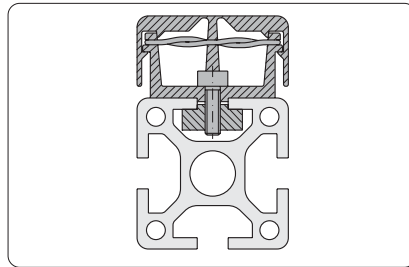

Mounting on profiles

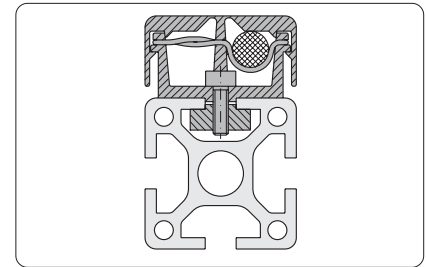

Ø<sub>max</sub> = 12 mm for cables and hoses

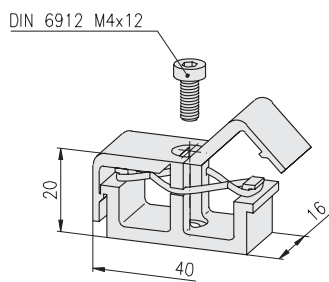

**Fastening elements for E-slot**

cap-screw DIN 6912 M4x12

T-Nut for subs. insertion, with leaf spring E, M4 1.324.EM4

spring-nut E, M4 1.33.EM4

T-slot nut E, M4 1.34.10EM4

**Description**

Cable and hose clamp

**Weight**

8 g

**Article-No.**

1.71.1010

**Block for cable binder,  
Cross-blocks for cable binder  
front-sided insertion,  
Cable binder**

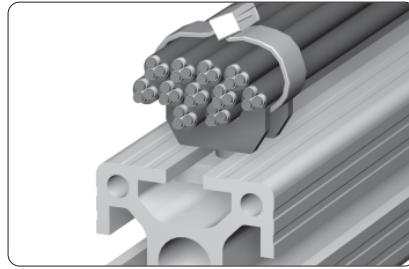

Block for cable binder

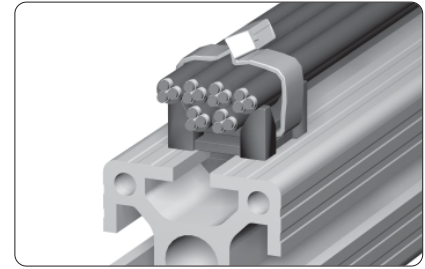

Cross-block for cable binder

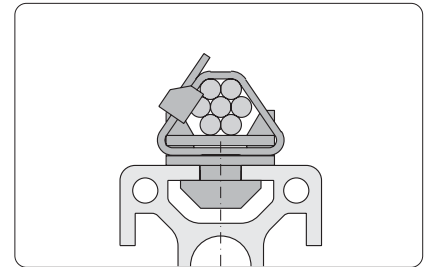
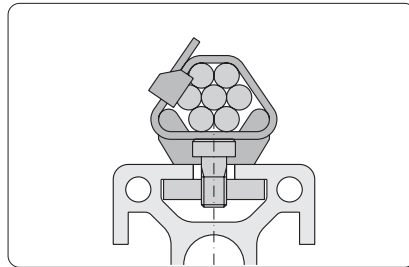

front-sided insertion

**Technical data**  
material: PA  
colour: black

**Application**  
Element for fixing single cables and hoses  
or large quantities

**Block for cable binder**

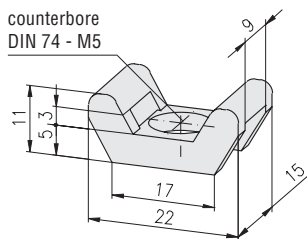

**Comments**  
Counterbore DIN 74 - M5 for  
cap-screw DIN 6912 - M5

Description	Weight	Article-No.
Block for cable binder	1.6 g	1.71.2010

**Cross-blocks for cable binder  
front-sided insertion**

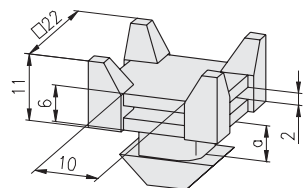

Description	a	Weight	Article-No.
Cross-block for cable binder F	2.2	4.0 g	1.71.2020F2
Cross-block for cable binder E3	3.0	4.0 g	1.71.2020E3
Cross-block for cable binder E4	4.0	4.0 g	1.71.2020E4

**Cable binder  
detachable**

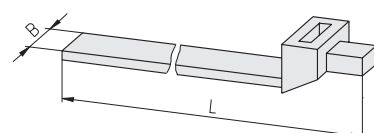

Description	BxL	Weight	Article-No.
Cable binder, detachable	4.8x145	0.7 g	1.71.2048145
Cable binder, detachable	9.0x140	1.9 g	1.71.2090140

**Installation rings**

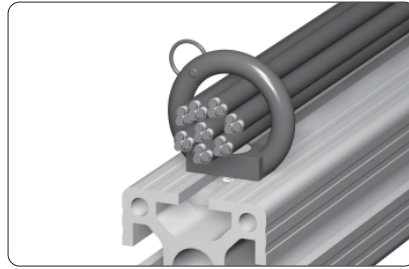

**Application**

Element for fixing large quantities of cables and hoses  
The rings can be opened for insertion

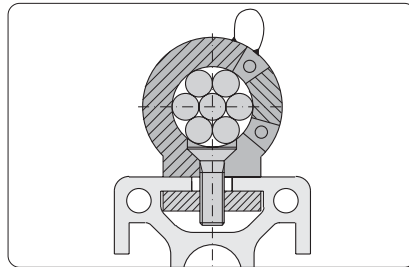

**Technical data**

material: PA-GF  
colour: black

**Comments**

Delivery unit incl. screw

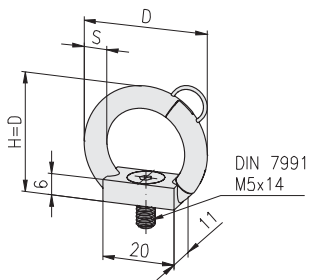

Description	D	s	Weight	Article-No.
Installation ring	Ø28.5	6.0	5 g	1.71.30285
Installation ring	Ø36.5	6.0	6 g	1.71.30365
Installation ring	Ø47.5	7.5	8 g	1.71.30475
Installation ring	Ø56.5	7.5	9 g	1.71.30565

**Mounting set for 19" profile**



**Application**

Fastening set for the assembly of 19" plug-in units and 19" profiles

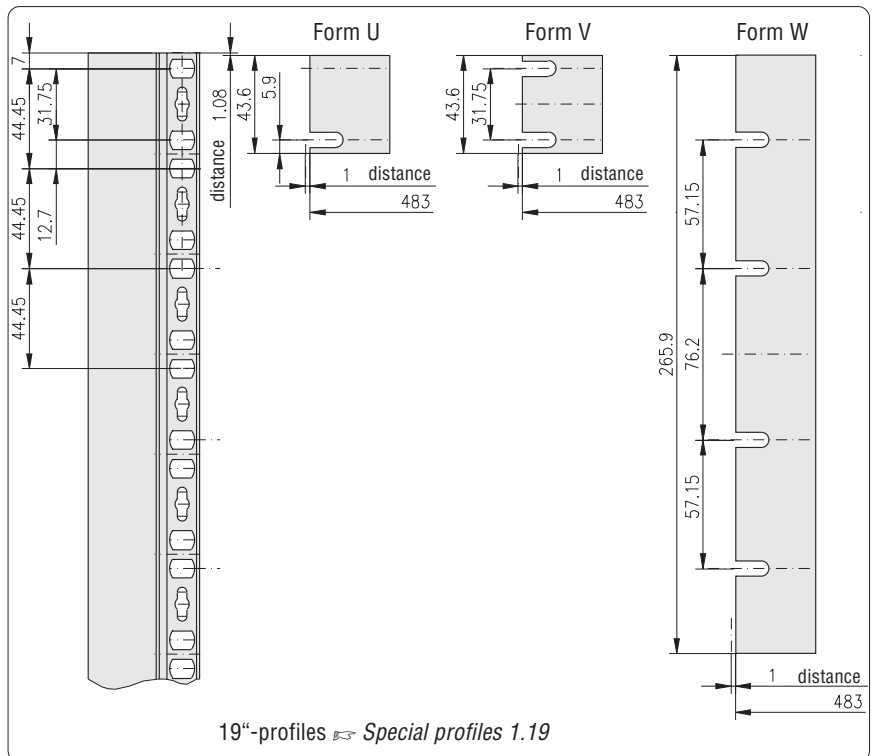
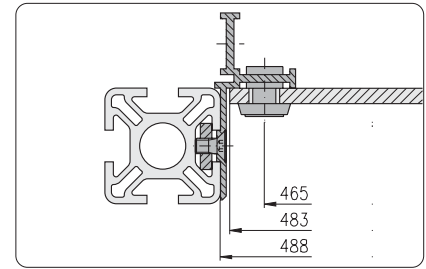

Dimensions for front panels and housings according to DIN 41494

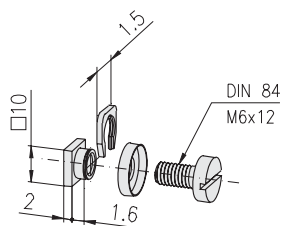

**Technical data**

screw and nut: steel, galvanised  
 plate and socket washer: PA, black  
 delivery unit: PU with 10 mounting sets

**Description**

Mounting set for 19" profile

**Weight**

70 g

**Article-No.**

1.72.2010.10

**Safety switches**

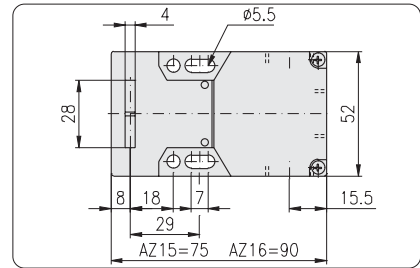
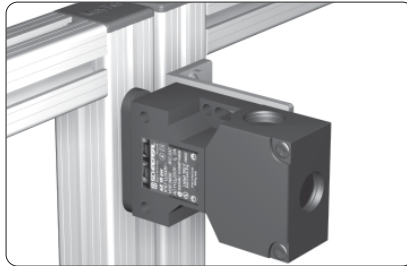

**Application**

Safety switch for the electrical interlocking of swinging or sliding doors

**Comments**

Smallest possible radius of operation of 150 mm

**with 1 safety contact**

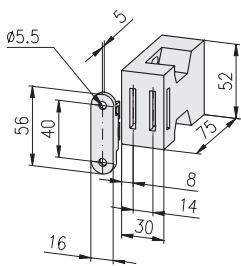

**Technical data**

Schmersal: Type AZ 15 zvrk-M16-2254  
IP 67 230V 4A

**Description**

Safety switch with 1 safety contact  
with 5 N - lock-in position

**Weight**

100 g

**Article-No.**

1.73.3010

**with 1 safety contact and 1 alarm contact**

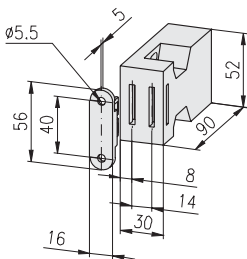

**Technical data**

Schmersal: Type AZ 16 zvrk-M16-2254  
IP 67 230V 4A

**Description**

Safety switch with 1 safety contact and 1 alarm contact  
with 5 N - lock-in position

**Weight**

125 g

**Article-No.**

1.73.3020

**with 1 closing and 1 positioning monitoring**

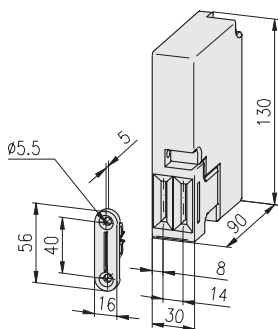

**Technical data**

Schmersal: Type AZM161sk - 33rk-24V-M16  
IP 65

**Comments**

Locking mechanism by spring  
Releasing by solenoid  
(closed-circuit system)  
24V electrical potential of coil

**Description**

Safety switch with 1 closing and 1 positioning monitoring

**Weight**

480 g

**Article-No.**

1.73.3030

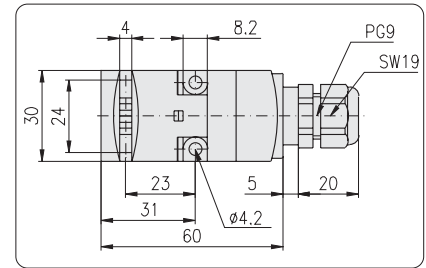
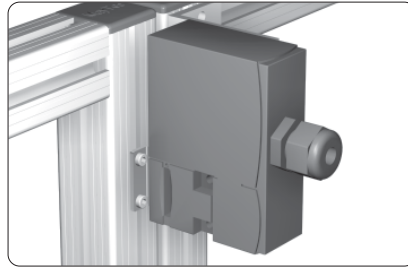
**Safety switches  
AZ 17**

**Application**

Safety switch for the electrical interlocking of swinging or sliding doors

**Technical data**

Schmersal: Type AZ 17  
4A / 230 VAC IP 67

**Comments**

Especially suitable for cramped mounting spaces

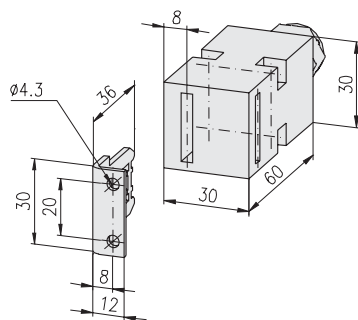
**Description**

Safety switch AZ 17-11 zk  
with 1 positive-break safety contact  
1 no contact

**Weight**

90 g

**Article-No.**

1.73.3111

Safety switch AZ 17-02 zk  
with 2 positive-break safety contacts

90 g

1.73.3112

**Guard locking devices  
AZM 170**
**Technical data**

Schmersal: Type AZM 170  
4A / 230 VAC IP 67

**Comments**

Locking mechanism by spring  
Releasing by solenoid  
(closed-circuit system)

**Description**

Guard locking device AZM 170-11 zk - 024  
with 1 positive-break safety contact  
1 no contact  
24V electrical potential of coil

**Weight**

300 g

**Article-No.**

1.73.3121

Guard locking device AZM 170-02 zk - 024  
with 2 positive-break safety contacts  
24V electrical potential of coil

300 g

1.73.3122

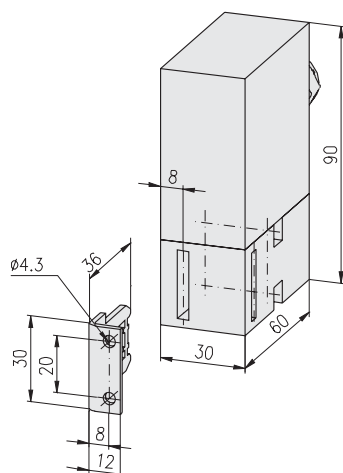
**Comments**

Locking mechanism by solenoid  
Releasing by spring  
(working current principle)

**Description**

Guard locking device AZM 170-11 zka  
with 1 positive-break safety contact  
1 no contact

**Weight**

300 g

**Article-No.**

1.73.3131

Guard locking device AZM 170-02 zka  
with 2 positive-break safety contacts

300 g

1.73.3132

**Safety interlocking-mountings for swinging door**

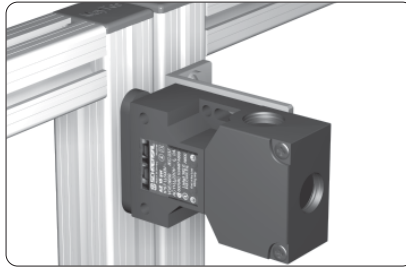

**Application**

Mounting element for electrical interlocking switches

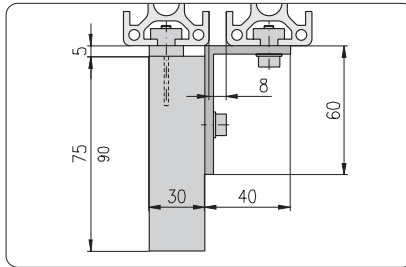

**Comments**

Assembly on profile 30x30  
profile 40x40  
profile 40x80

**Technical data**

material: aluminium  
surface: neutral anodised

**for swinging door**

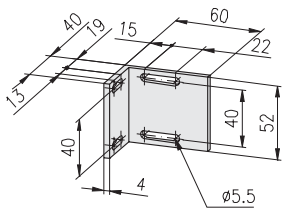

**Description**

Safety interlocking-mounting for swinging door

**Weight**

46 g

**Article-No.**

1.73.4010

**with lock for swinging door**

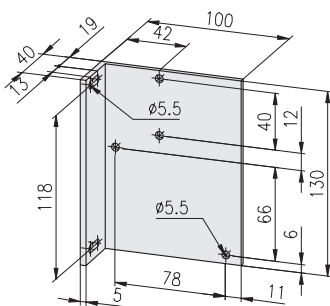

**Description**

Safety interlocking-mounting with lock for swinging door

**Weight**

183 g

**Article-No.**

1.73.4020

**Safety interlocking-mountings for sliding door**

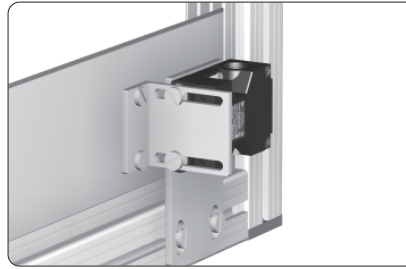

**Application**

Mounting element for the electrical interlocking of sliding doors

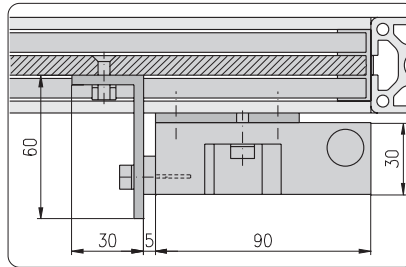

**Comments**

Assembly on profile 30x30  
profile 40x40  
profile 40x80

**Technical data**

material: aluminium  
surface: neutral anodised

**Contact bracket-mounting for sliding door**

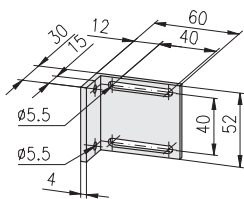

**Description**

Contact bracket-mounting for sliding door

**Weight**

41 g

**Article-No.**

1.73.4030

**Safety interlocking-mounting for sliding door**

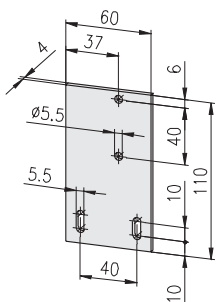

**Description**

Safety interlocking-mounting for sliding door

**Weight**

70 g

**Article-No.**

1.73.4040



**Safety interlocking-mountings  
AZ 17  
for swinging door**

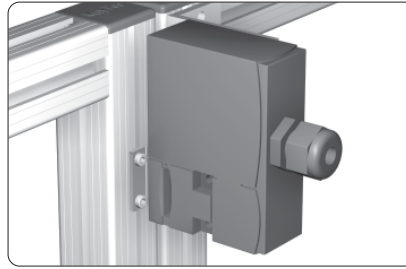

**Application**

- Fastening elements for:
- safety switches AZ 17
  - safety closing AZM 170 at sliding doors

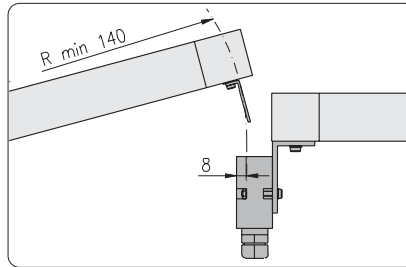

Activation key  
Mounting vertical to swivel radius

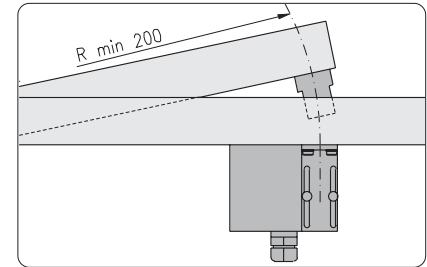

Activation key  
Mounting horizontal to swivel radius

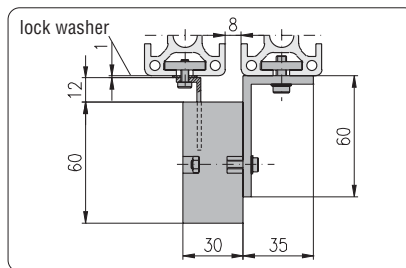

**Comments**

Assembly on  
profile 30x30  
profile 40x40  
profile 40x80

**Technical data**

material: aluminium  
surface: neutral anodised

**Delivery**

Incl. lock washers DIN 9021 Ø4.3 mm  
for mounting activation key

**Description**

Safety interlocking-mounting AZ 17  
for swinging door

**Weight**

26 g

**Article-No.**

1.73.4110

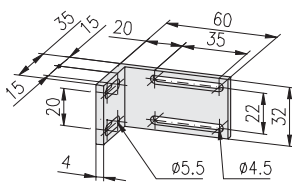

**Safety interlocking-mountings  
AZ 17  
for sliding door**

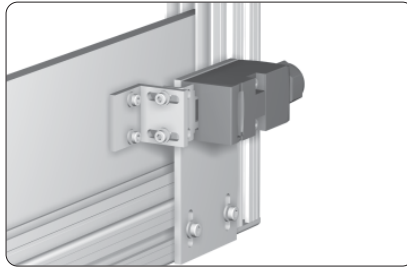

**Application**

- Fastening elements for:
- safety switches AZ 17
  - safety closing AZM 170 at sliding doors

**Mounting position:**  
Safety switch parallel to sliding door

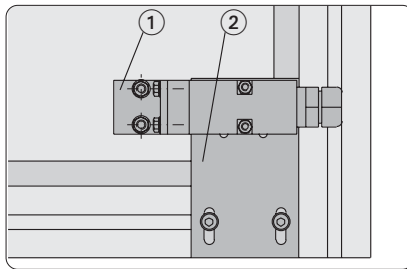

Fastening plate horizontal

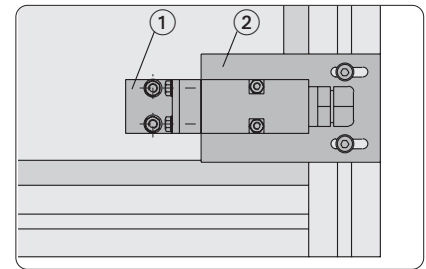

Fastening plate vertical

- ① Contact bracket-mounting AZ 17
- ② Safety interlocking-mounting AZ 17

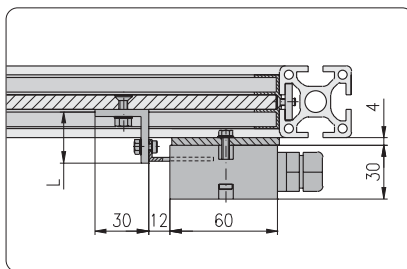

**Mounting position:**  
Safety switch across to sliding door

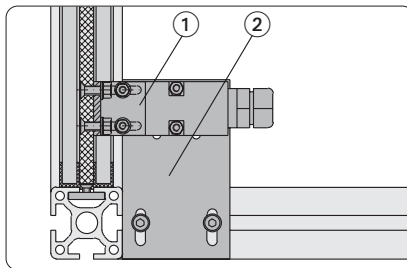

Fixing at cross profile

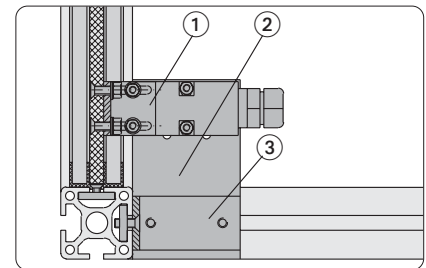

Fixing at longitudinal profile

- ① Contact bracket-mounting AZ 17
- ② Safety interlocking-mounting AZ 17
- ③ Angle for safety interlocking-mounting AZ 17

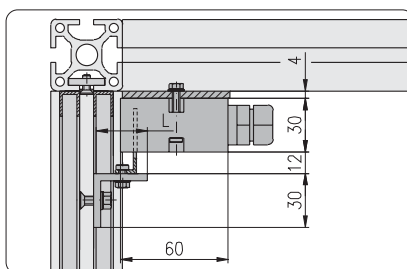

**Safety interlocking-mountings  
AZ 17  
for sliding door**

**Technical data**  
material: aluminium  
surface: neutral anodised

**Comments**  
Assembly on  
profile 30x30  
profile 40x40  
profile 40x80

**Contact bracket-mounting AZ 17  
for sliding door**

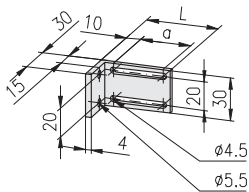

Description	a	Weight	Article-No.
Contact bracket-mounting AZ 17 for sliding door, L 30	15	16 g	1.73.4123
Contact bracket-mounting AZ 17 for sliding door, L 40	25	19 g	1.73.4124
Contact bracket-mounting AZ 17 for sliding door, L 50	35	21 g	1.73.4125

**Safety interlocking-mounting AZ 17  
for sliding door**

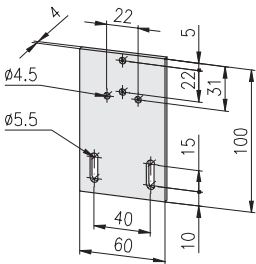

Description	Weight	Article-No.
Safety interlocking-mounting AZ 17 for sliding door	62 g	1.73.4130

**Angle for safety interlocking-mounting AZ 17  
for sliding door**

**Comments**  
Countersink DIN 74 - M5 for  
countersunk screw DIN 7991 - M5

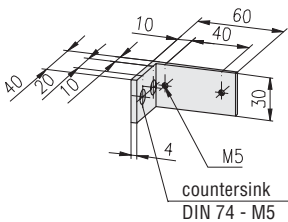

Description	Weight	Article-No.
Angle for safety interlocking-mounting AZ 17 for sliding door	30 g	1.73.4140

**Sensor brackets**



**Application**

For fastening of sensors



**Assembly**

The toothed lock washer is fixed in profile slot and guarantees a reliable positioning

**Technical data**

material: PA, black

**Fastening elements**

cap-screw DIN 6912, M4

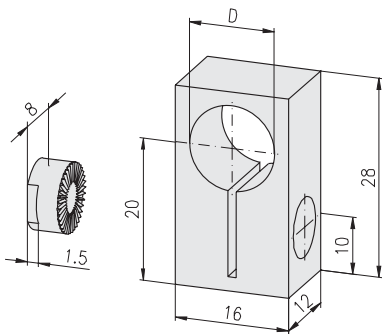

Description	D	Weight	Article-No.
Sensor bracket 8	Ø6.5	5.5 g	1.73.80806
Sensor bracket 8	Ø8	5.4 g	1.73.80808
Sensor bracket 8	Ø12	4.6 g	1.73.80812

**Electrical installation trunking**



**Application**

- To supply machines and work stations with:
- alternating current
  - high-tension current
  - air

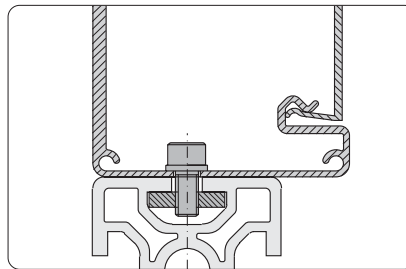

Mounting direct to profile

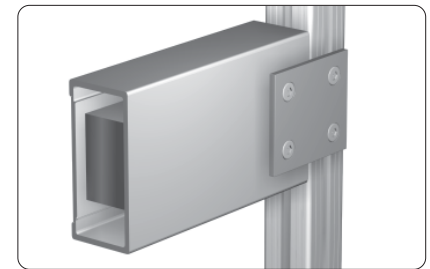

Mounting with connection plate

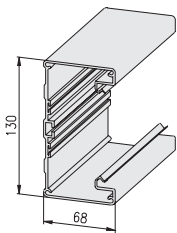

**E-trunking Alu, 68x130**

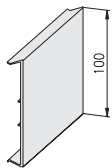

Description	Weight	Article-No.
E-trunking Alu, 68x130, bar 6 m	13 kg	1.74.1101.60
 E-trunking Alu, 68x130, cut to length	2.17 kg/m	1.74.1101-A00A00/... /... = length in mm

**E-trunking pre-cut lid**



Description	Weight	Article-No.
E-trunking pre-cut lid Alu, bar 6 m	5 kg	1.74.1102.60
 E-trunking pre-cut lid Alu, cut to length	834 g/m	1.74.1102-A00A00/...
E-trunking pre-cut lid PVC, light grey, bar 2 m	760 g	1.74.1103.20
 E-trunking pre-cut lid PVC, l. grey, cut to length	380 g/m	1.74.1103-A00A00/... /... = length in mm

**E-trunking end cap**

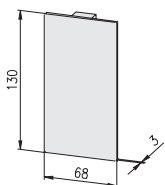

Description	Weight	Article-No.
E-trunking end cap Alu	230 g	1.74.1104

**E-trunking coupling pin**

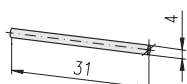

**Comments**

Coupling pin for positioning and elongating the electrical trunking

Description	Weight	Article-No.
E-trunking coupling pin	3 g	1.74.1105

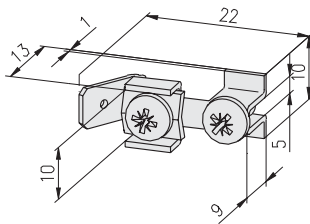
**E-trunking earth terminal**

Description	Weight	Article-No.
E-trunking earth terminal	6.8 g	1.74.1106

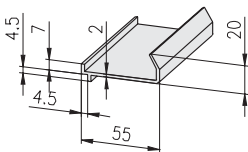
**E-trunking partition**

Description	Weight	Article-No.
E-trunking partition, bar 2 m	540 g	1.74.1107.20
 E-trunking partition, cut to length	270 g/m	1.74.1107-A00A00/... /... = length in mm

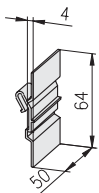
**E-trunking clip**

**Comments**  
Clip to support partition

Description	Weight	Article-No.
E-trunking clip	7 g	1.74.1108

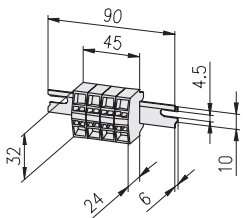
**E-trunking terminal strip**

Description	Weight	Article-No.
E-trunking terminal strip, 4gang	43 g	1.74.11094
E-trunking terminal strip, 5gang	50 g	1.74.11095

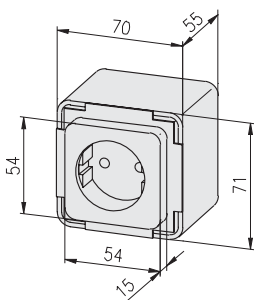
**Socket**

Description	Weight	Article-No.
Socket	150 g	1.74.2201

**Single parts**

Socket insert	76 g	1.74.2201/01
Socket box, black	68 g	1.74.2xxx/01
Mains cable cleat	6 g	1.74.2xxx/02

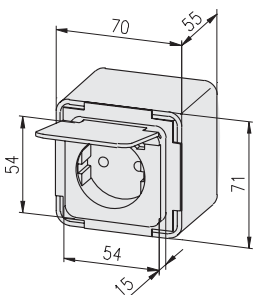
**Socket with hinged cover**

Description	Weight	Article-No.
Socket with hinged cover	163 g	1.74.2202

**Single parts**

Socket with hinged cover	90 g	1.74.2202/01
Socket box, black	67 g	1.74.2xxx/01
Mains cable cleat	6 g	1.74.2xxx/02

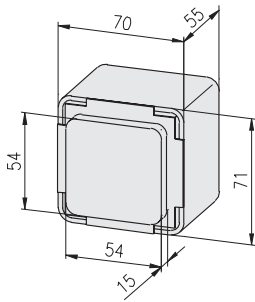
**Rocker switch**

Description	Weight	Article-No.
Rocker switch	137 g	1.74.2301

**Single parts**

Rocker switch insert	46 g	1.74.2301/01
Rocker for switch	18 g	1.74.2301/02
Socket box, black	67 g	1.74.2xxx/01
Mains cable cleat	6 g	1.74.2xxx/02

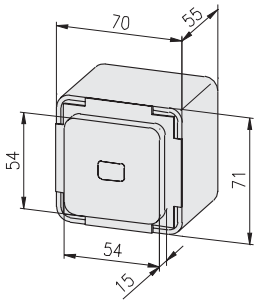
**Rocker control switch**

Description	Weight	Article-No.
Rocker control switch	154 g	1.74.2302

**Single parts**

Rocker control switch insert	57 g	1.74.2302/01
Rocker for control switch	24 g	1.74.2302/02
Socket box, black	67 g	1.74.2xxx/01
Mains cable cleat	6 g	1.74.2xxx/02

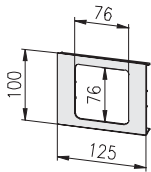
**Pre-cut lid, 1gang**

Description	Weight	Article-No.
Pre-cut lid, Alu, 1gang	82 g	1.74.3111
Pre-cut lid, PVC, 1gang, light grey	28 g	1.74.3121

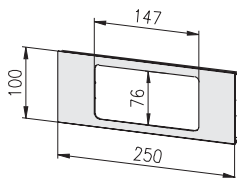
**Pre-cut lid, 2gang**

Description	Weight	Article-No.
Pre-cut lid, Alu, 2gang	83 g	1.74.3112
Pre-cut lid, PVC, 2gang, light grey	59 g	1.74.3122

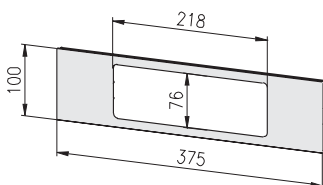
**Pre-cut lid, 3gang**

Description	Weight	Article-No.
Pre-cut lid, Alu, 3gang	113 g	1.74.3113
Pre-cut lid, PVC, 3gang, light grey	88 g	1.74.3123

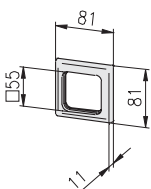
**Cover frame, 1gang**

Description	Weight	Article-No.
Cover frame, 1gang	21 g	1.74.4111

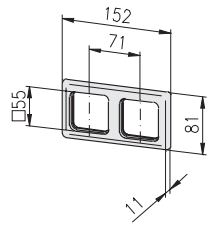
**Cover frame, 2gang**

Description	Weight	Article-No.
Cover frame, 2gang	39 g	1.74.4112

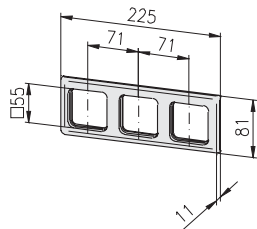
**Cover frame, 3gang**

Description	Weight	Article-No.
Cover frame, 3gang	58 g	1.74.4113

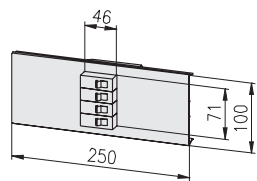
**Miniature circuit breaker 10 A**

Description	Pcs.	Weight	Article-No.
Miniature circuit breaker, 10 A, 4gang	1	763 g	1.74.5110

**Single parts**

Miniature circuit breaker, flat, unipolar, 10 A	4	100 g	1.74.5110/01
Circuit breaker mounting box, 4gang	1	230 g	1.74.51xx/02
Pre-cut lid, Alu	1	133 g	1.74.51xx/03

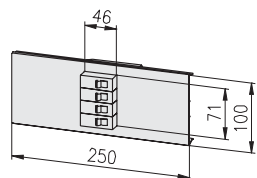
**Miniature circuit breaker 16 A**

Description	Pcs.	Weight	Article-No.
Miniature circuit breaker, 16 A, 4gang	1	763 g	1.74.5116

**Single parts**

Miniature circuit breaker, flat, unipolar, 16 A	4	100 g	1.74.5116/01
Circuit breaker mounting box, 4gang	1	230 g	1.74.51xx/02
Pre-cut lid, Alu	1	133 g	1.74.51xx/03

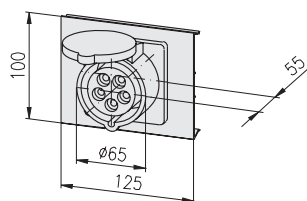
**CEE heavy-power socket 16 A**

Description	Pcs.	Weight	Article-No.
CEE heavy-power socket 16 A	1	915 g	1.74.6116

**Single parts**

CEE heavy-power socket with lid, 16 A	1	645 g	1.74.6116/01
CEE socket box	1	225 g	1.74.61xx/02
CEE pre-cut lid, Alu	1	45 g	1.74.61xx/03



## Electrical installation trunking

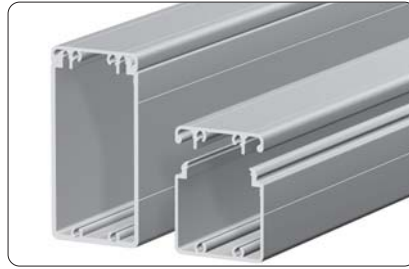

**Application**

Installation trunking for electrical and pneumatic lines

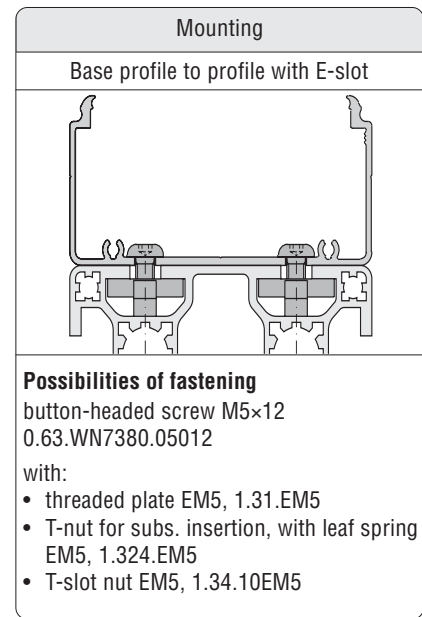
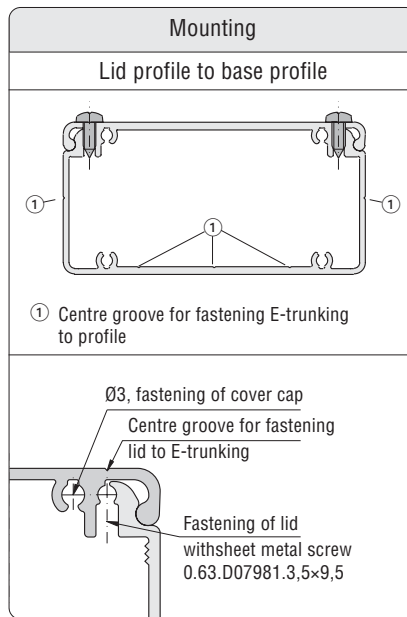
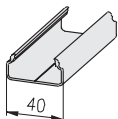
**Technical data**

 material: aluminium  
 surface: neutral anodised

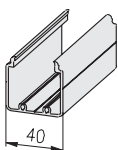
**E-trunking Alu**

Description	Weight	Article-No.
E-trunking Alu 40×20, bar 6 m	1.80 kg	1.19.204020G.60
E-trunking Alu 40×20, cut to length	0.30 kg/m	1.19.204020G-A00A00/... /... = length in mm

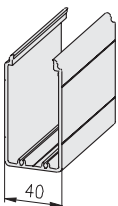

Description	Weight	Article-No.
E-trunking Alu 40×40, bar 6 m	3.66 kg	1.19.204040G.60
E-trunking Alu 40×40, cut to length	0.61 kg/m	1.19.204040G-A00A00/... /... = length in mm



Description	Weight	Article-No.
E-trunking Alu 40×80, bar 6 m	7.20 kg	1.19.204080G.60
E-trunking Alu 40×80, cut to length	1.20 kg/m	1.19.204080G-A00A00/... /... = length in mm

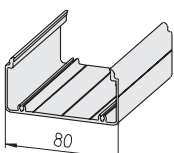

Description	Weight	Article-No.
E-trunking Alu 80×40, bar 6 m	5.10 kg	1.19.208040G.60
E-trunking Alu 80×40, cut to length	0.85 kg/m	1.19.208040G-A00A00/... /... = length in mm

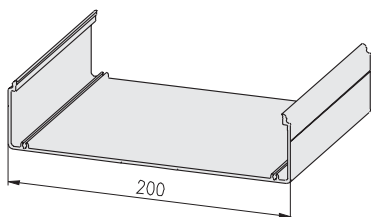

Description	Weight	Article-No.
E-trunking Alu 200×50, bar 6 m	12.00 kg	1.19.220050G.60
 E-trunking Alu 200×50, cut to length	2.0 kg/m	1.19.220050G-L00L00/... /... = length in mm

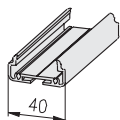
**E-trunking Alu, for clips**

Description	Weight	Article-No.
E-trunking Alu 40×20, Clips, bar 6 m	3.00 kg	1.19.214020G.60
 E-trunking Alu 40×20, Clips, cut to length	0.50 kg/m	1.19.214020G-A00A00/... /... = length in mm

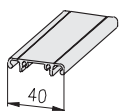
**E-trunking Alu, lids**

Description	Weight	Article-No.
E-trunking Alu, lid 40, bar 6 m	2.10 kg	1.19.2040D.60
 E-trunking Alu, lid 40, cut to length	0.35 kg/m	1.19.2040D-A00A00/... /... = length in mm

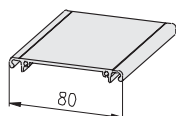

Description	Weight	Article-No.
E-trunking Alu, lid 80, bar 6 m	3.54 kg	1.19.2080D.60
 E-trunking Alu, lid 80, cut to length	0.59 kg/m	1.19.2080D-A00A00/... /... = length in mm

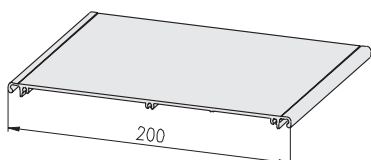

Description	Weight	Article-No.
E-trunking Alu, lid 200, bar 6 m	9.00 kg	1.19.2200D.60
 E-trunking Alu, lid 200, cut to length	1.50 kg/m	1.19.2200D-L00L00/... /... = length in mm

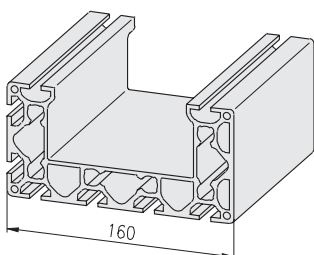
**E-trunking Alu**

Description	Weight	Article-No.
Profile 80×160, 8E, P, bar 6 m	47.40 kg	1.11.080160.89P.60
 Profile 80×160, 8E, P, cut to length	7.90 kg/m	1.11.080160.89P-L00L00/... /... = length in mm

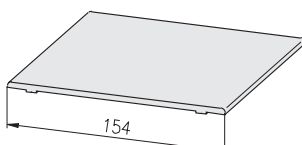
**E-trunking Alu, lid**

Description	Weight	Article-No.
Profile pre-cut lid 120, bar 6 m	10.80 kg	1.19.1101120.60
 Profile pre-cut lid 120, cut to length	1.80 kg/m	1.19.1101120-L00L00/... /... = length in mm

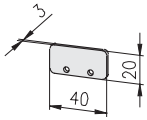
**E-trunking Alu, end plates**

Description	Weight	Article-No.
E-trunking Alu, end plate 40x20	6.0 g	1.75.2040202

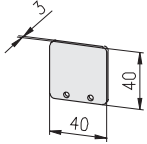

Description	Weight	Article-No.
E-trunking Alu, end plate 40x40	12.3 g	1.75.2040402

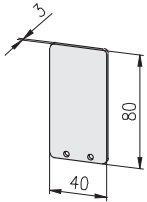

Description	Weight	Article-No.
E-trunking Alu, end plate 40x80	25.0 g	1.75.2040802

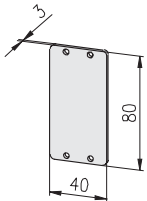

Description	Weight	Article-No.
E-trunking Alu, end plate 40x80, 4B	24.6 g	1.75.2040804

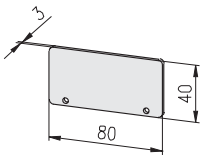

Description	Weight	Article-No.
E-trunking Alu, end plate 80x40	25.0 g	1.75.2080402

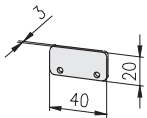

Description	Weight	Article-No.
E-trunking Alu, end plate 40x20, Clips	6.0 g	1.75.2140202

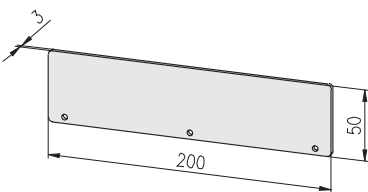

Description	Weight	Article-No.
E-trunking Alu, end plate 200x50	80.7 g	1.75.2200503

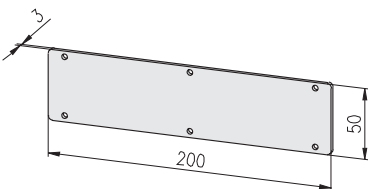

Description	Weight	Article-No.
E-trunking Alu, end plate 200x50, 6B	80.4 g	1.75.2200506

**Corner elements  
for wire net mounting profile**

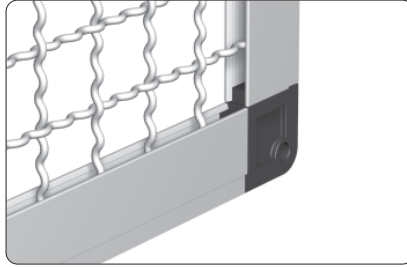

**Application**

This mounting profile allows simple and safe installation of screens

**Comments**

Wire net mounting profile ↗ 1.19.1423...

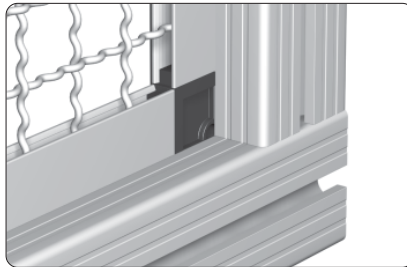

Mounting in the profile slot

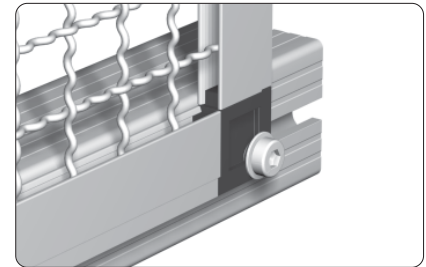

Fastening from the outside

**Technical data**

material: PA - GF  
colour: black

**Outside corner**

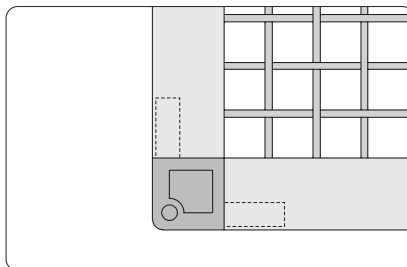
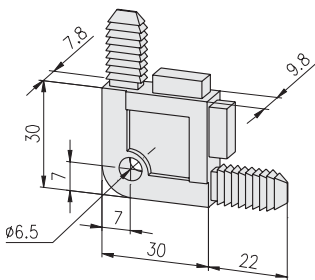

Outside corner

**Description**

Corner element - outside

**Weight**

13 g

**Article-No.**

1.81.1010

**Inside corner**

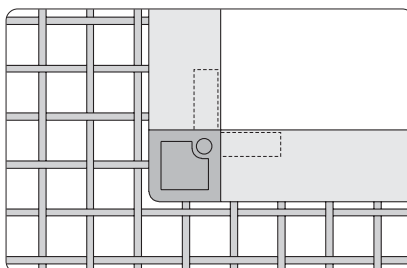
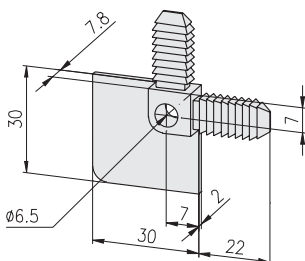

Inside corner

**Description**

Corner element - inside

**Weight**

6 g

**Article-No.**

1.81.1020

**Corner element 33  
for wire net mounting profile 33x10**

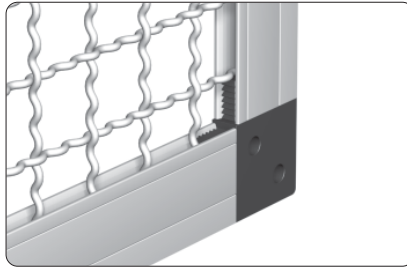

**Application**

This profile allows simple and safe installation of wire nets

**Comments**

Wire net mounting profile 33x10  
➔ 1.19.1423...

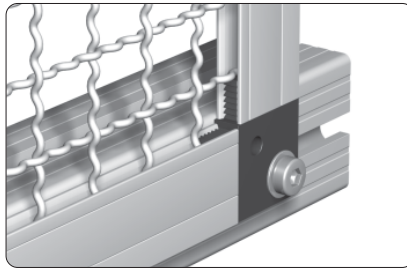

Outside mounting

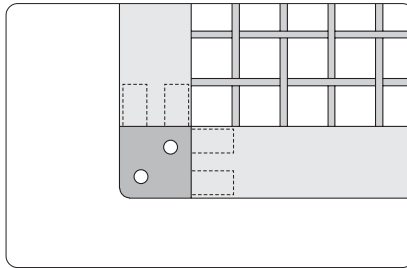

Outside corner

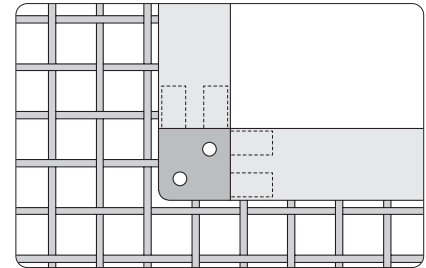

Inside corner

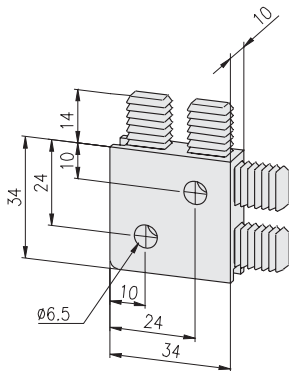

**Technical data**

material: PA - GF  
colour: black

**Description**

Corner element 33

**Weight**

16 g

**Article-No.**

1.81.23310

**Mounting sockets**

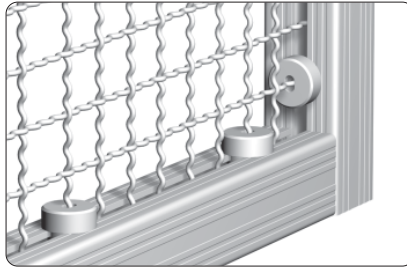

**Application**

For stable and vibration free fastening of wire nets

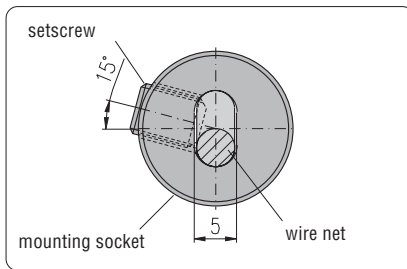
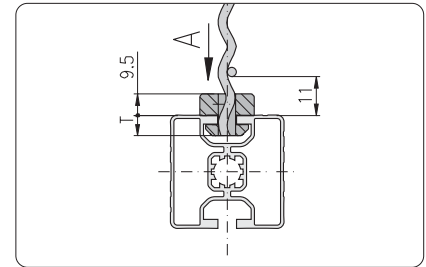
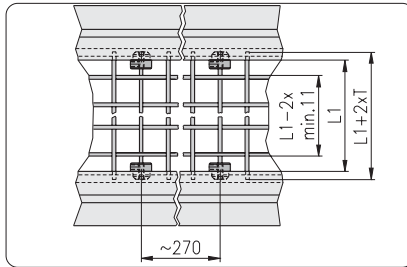

**Assembly**

- plug terminal sockets at a distance of about 270 mm on the wire net
- push on profile
- rotate mounting sockets with headless setscrew DIN 913 M6x8 at an angle of 15°

View "A"

**Technical data**

material: aluminium  
surface: neutral anodised

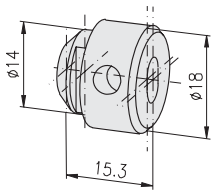

Description	T	Weight	Article-No.
Mounting socket, F	5	6 g	1.81.510F

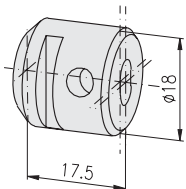

Description	T	Weight	Article-No.
Mounting socket, E3	9	6 g	1.81.510E3

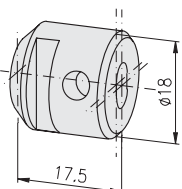

Description	T	Weight	Article-No.
Mounting socket, E4	10	6 g	1.81.510E4

Panel elements

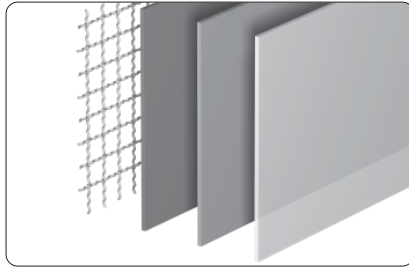

**Application**

Panel elements to cover machine frames, work stations, partition walls.

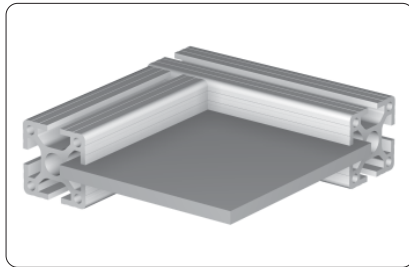

Panel element, fixing directly in the slot

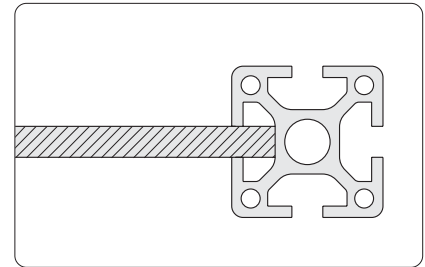

Installation accessories ↗ 1.41



Panel elements close to the outer contour by subsequent slitting of the profiles

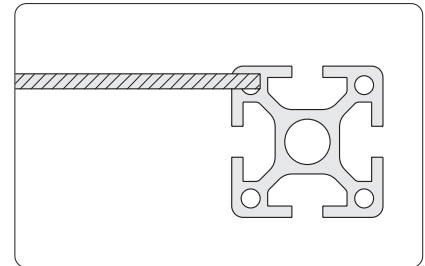

Special slits ↗ 1.1E.01



Panel elements close to the outer contour by fixing with angle or mounting block

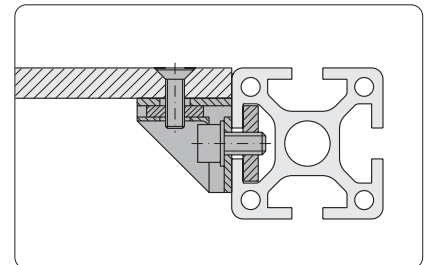

Mounting blocks ↗ 1.64

**Chipboards**
**both sides coated with melamine**

Technical data	
surface:	both sides coated with melamine
structure:	pearl
RAL 9002:	grey-white
formaldehydemission:	complies to safety standards §9 paragraph 3
light-fastness:	point 6 as per DIN 53799
temperature resistance:	- 25°C to 130°C
chemical resistance:	resistant against organic food, light acid contents and alkaline solution, gasoline, oil, tested as per DIN 53799
chipboard:	high frequency glued laminated chipboard
Technical values on DIN 68765 and 53799	
bulk density:	approx. 700 kg/m <sup>3</sup>
thickness tolerance:	+0.5 -0.3 mm
weight:	S = 8 mm    5.6 kg/m <sup>2</sup> S = 16 mm    11.2 kg/m <sup>2</sup> S = 19 mm    13.3 kg/m <sup>2</sup>
cut to length:	1.82.□□□-99/□□□□×□□□□ 1.82.□□□-99/□□□□×□□□□    type 1.82.□□□-99/□□□□×□□□□    length×width in mm

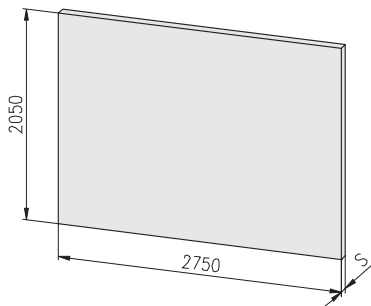

Description	S	RAL	Weight	Article-No.
Chipboard	8	9002	32 kg	1.82.083.00
Chipboard	16	9002	64 kg	1.82.163.00
Chipboard	19	9002	75 kg	1.82.193.00

**Solid plastic panels  
coated with melamine**

Technical data	
surface:	both sides coated with melamine
structure:	pearl
RAL 9002:	grey-white
solid plastic panel:	made of Phenolplastic high pressure plate (HPL) of laminated material with all generally known merits of this substance.
Technical values on DIN 19926 and 53799	
bulk density:	approx. 1,500 kg/m <sup>3</sup>
thickness tolerance:	-0.6 mm
weight:	S = 4 mm    6 kg/m <sup>2</sup> S = 8 mm    12 kg/m <sup>2</sup>
cut to length:	1.83.□□□-99/□□□□×□□□□ 1.83.□□□-99/□□□□×□□□□    type 1.83.□□□-99/□□□□×□□□□    length×width in mm

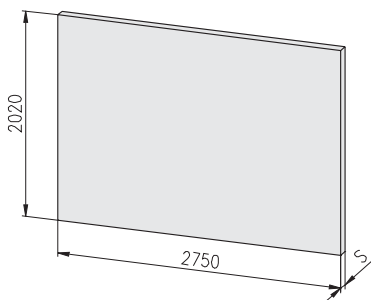

Description	S	RAL	Weight	Article-No.
Solid plastic panel	4	9002	33 kg	1.83.043.00
Solid plastic panel	8	9002	66 kg	1.83.083.00



Alu-plastic composite panels

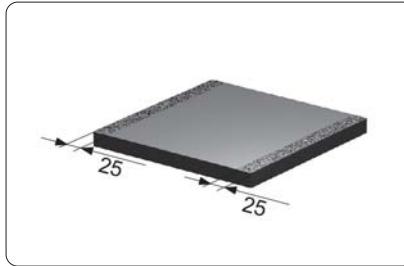

**Comments**

The anodised composite panels have contact strips of 25 mm width on the short sides.

Technical data	
alu-plastic composite panel:	PE with alu coating on both sides
surface:	neutral anodised, E6/EV1
temperature resistance:	- 50°C to 80°C
chemical resistance:	resistant against organic food, light acid contents and alkaline solutions, gasoline, oil
thickness tolerance:	-0.6 mm
weight:	S = 4 mm 5.5 kg/m <sup>2</sup> S = 6 mm 7.3 kg/m <sup>2</sup> S = 8 mm 9.1 kg/m <sup>2</sup>
cut to length:	1.85.□□□-99/□□□□×□□□□ 1.85.□□□-99/□□□□×□□□□ type 1.85.□□□-99/□□□□×□□□□ length×width in mm

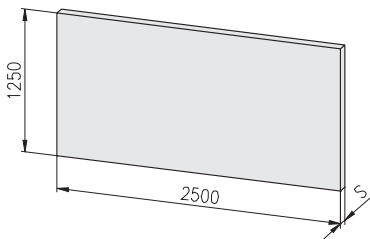

Description	S	Weight	Article-No.
Alu-plastic composite panel	4	17.2 kg	1.85.040.00
Alu-plastic composite panel	6	22.8 kg	1.85.060.00

## Acrylic

### Application

Doors, panels and guards

Technical data	
thickness tolerance:	± 5%
weight:	S = 4 mm 4.8 kg/m <sup>2</sup> S = 6 mm 7.2 kg/m <sup>2</sup> S = 8 mm 9.6 kg/m <sup>2</sup>
cut to length:	1.86.□□□-99/□□□□×□□□□ 1.86.□□□-99/□□□□×□□□□ type 1.86.□□□-99/□□□□×□□□□ length×width in mm

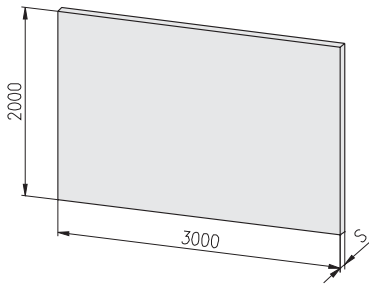

Description	S	Colour	Weight	Article-No.
Acrylic xt	4	transparent	28.8 kg	1.86.041.00
Acrylic xt	4	bronze 802	28.8 kg	1.86.042.00
Acrylic xt	6	transparent	43.2 kg	1.86.061.00
Acrylic xt	6	bronze 802	43.2 kg	1.86.062.00
Acrylic xt	8	transparent	57.6 kg	1.86.081.00
Acrylic xt	8	bronze 802	57.6 kg	1.86.082.00

## Polycarbonate (Makrolon)

### Application

Doors, panels and guards with stringent security requirements as polycarbonate offers high impact resistance and strength against breakage

Technical data	
thickness tolerance:	+0.8 mm
weight:	S = 4 mm 4.8 kg/m <sup>2</sup> S = 6 mm 7.2 kg/m <sup>2</sup> S = 8 mm 9.6 kg/m <sup>2</sup>
cut to length:	1.87.□□□-99/□□□□×□□□□ 1.87.□□□-99/□□□□×□□□□ type 1.87.□□□-99/□□□□×□□□□ length×width in mm

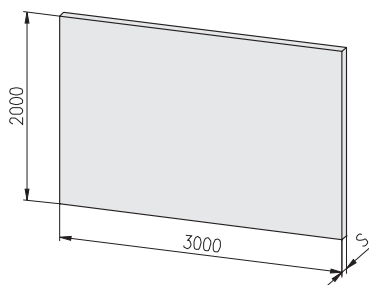

Description	S	Colour	Weight	Article-No.
Polycarbonate	4	transparent	28.8 kg	1.87.041.00
Polycarbonate	4	bronze 885	28.8 kg	1.87.042.00
Polycarbonate	6	transparent	43.2 kg	1.87.061.00
Polycarbonate	6	bronze 885	43.2 kg	1.87.062.00
Polycarbonate	8	transparent	57.6 kg	1.87.081.00
Polycarbonate	8	bronze 885	57.6 kg	1.87.082.00

Properties		Acrylic xt	Poly-carbonate
<b>Mechanical properties</b>			
	<b>20°C</b>		
maximum extent of flex	MN/m <sup>2</sup>	107.9	68.7
break / shear point	%	5.5	> 110.0
compression	MN/m <sup>2</sup>	117.7	78.5
elasticity	MN/m <sup>2</sup>	3,188.0	2,256.0
marring resistance	J/m <sup>2</sup>	29.4	392.4
impact resistance	kJ/m <sup>2</sup>	19.6	no break
tensile strength	MN/m <sup>2</sup>	73.6	68.7
<b>Thermal properties</b>			
temperature distortion according to 'Vicat'	°C	110	170
melting point	°C	168	170
temperature range under static load (max.)	°C	70	130
temperature range under static load (min.)	°C	-40	-100

Wire net, Alu

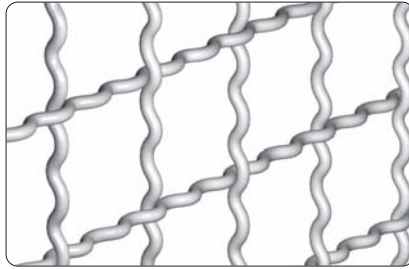

**Application**

For protective coverings and partition walls

**Comments**

Mounting in the profile:

- with sponge rubber  1.41.6□□
- with wire net m. prof.  1.19.1423...
- with wedge profile  1.41.51E□□
- with framing profile  1.41.710.□
- with mounting sockets  1.81.510□□

**Technical data**

material:	Aluminium	
surface:	blank	
weight:	3×20×20 mm	1.85 kg/m <sup>2</sup>
	4×30×30 mm	2.25 kg/m <sup>2</sup>
length of ring:	25 m	
cut to length:	1.88.□□□-99/□□□□×□□□□	
	1.88.□□□-99/□□□□×□□□□ type	
	1.88.□□□-99/□□□□×□□□□ length×width in mm	

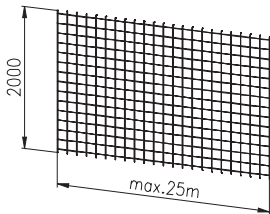

Description	Weight	Article-No.
Wire net, Alu 3×20×20	92.5 kg	1.88.322.00
Wire net, Alu 4×30×30	112.5 kg	1.88.433.00

Wire net, steel

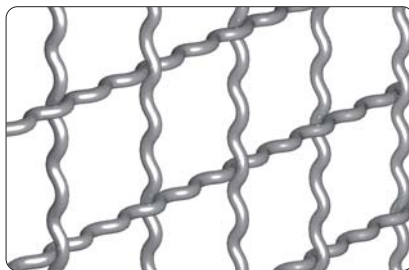

**Application**

For protective coverings and partition walls

**Comments**

Mounting in the profile:

- with sponge rubber  1.41.6□□
- with wire net m. prof.  1.19.1423...
- with wedge profile  1.41.51E□□
- with framing profile  1.41.710.□
- with mounting sockets  1.81.510□□

**Technical data**

material:	steel	
surface:	galvanised	
weight:	4×30×30 mm	27 kg/plate
	4×40×40 mm	24 kg/plate
size of plate:	3.000×1.810 mm	
cut to length:	1.88.□□□-99/□□□□×□□□□	
	1.88.□□□-99/□□□□×□□□□ type	
	1.88.□□□-99/□□□□×□□□□ length×width in mm	

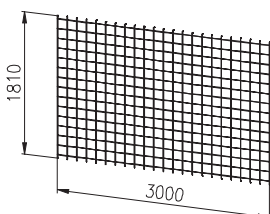

Description	Weight	Article-No.
Wire net, steel 4×30×30	27 kg	1.88.143030
Wire net, steel 4×40×40	24 kg	1.88.144040

**Grid, steel welded**



**Application**

For protective coverings and partition walls

**Comments**

Mounting in the profile:

- with sponge rubber ↗ 1.41.6□□
- with wire net m. prof. ↗ 1.19.1423...
- with wedge profile ↗ 1.41.51E□.□
- with framing profile ↗ 1.41.710.□
- with mounting sockets ↗ 1.81.510□□

**Technical data**

material:	steel
surface:	electrogalvanised
weight:	3×25×25 mm 8.9 kg/plate 4×40×40 mm 9.8 kg/plate
size of plate:	2.000×1.000 mm
cut to length:	1.88.□□□-99/□□□□×□□□□ 1.88.□□□-99/□□□□×□□□□ type 1.88.□□□-99/□□□□×□□□□ length×width in mm

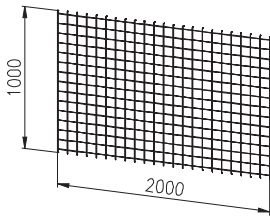

Description	Weight	Article-No.
Grid, steel 3×25×25	8.9 kg	1.88.232525
Grid, steel 4×40×40	9.8 kg	1.88.244040

**Button head screws**



**Application**

Button head screws for the mounting of additional elements

**Technical data**

material: steel  
surface: galvanised

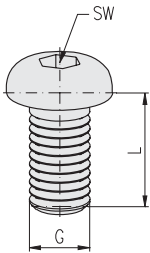

Description	G×L	Weight	Article-No.
Button head screw	M5×12	2.4 g	0.63.WN7380.05012
Button head screw	M8×12	6.5 g	0.63.WN7380.08012
Button head screw	M8×18	8.5 g	0.63.WN7380.08018
Button head screw	M8×30	12.6 g	0.63.WN7380.08030

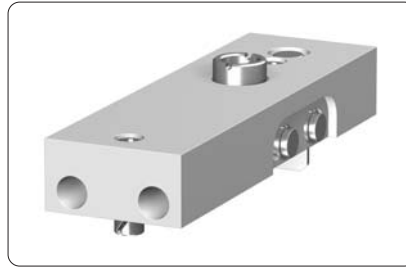
**Press in device  
for knurled cross bushing**

**Technical data**

Base body:

- material: aluminium
- surface: natural anodised

Axle bolt, Spring:

- material: stainless steel

Other:

- material: steel
- surface: hardened

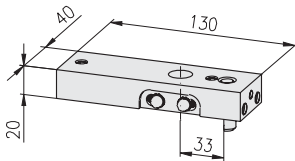

Description	Weight	Article-No.
Press in device for knurled cross bushing	310.0 g	1.98.11.21.B00R

Single parts	Pcs	Weight	Article-No.
Base body	1	216.0 g	1.98.11.21.B00R/01
Stopping pin	1	21.2 g	1.99.01112-05
Set screw for stop pin	1	1.8 g	1.99.01112-06
Dowel pin ISO 8752 (DIN 1481), 8×24 (for drill jig)	2	6.5 g	0.69.I08752.08024
Axle bolt complete, Ø8g 6×35 mm	2	15.6 g	1.98.11.21.B00R/05
Hex-socket set screw, DIN 913, M8×25	4	6.6 g	0.63.D00913.08.025
Spring for T-screw, E	4	0.1 g	1.34.E00/02

Tx screw driver



**Technical data**

material: steel, hardened  
 surface: nickel-plated

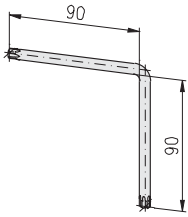

**Description**

Tx screw driver for Torx 40 screws

**Weight**

54.0 g

**Article-No.**

1.98.T40.090090

Cross bushings / Anchors		Drill								Milling cutter										
		MK		cylindrical shaft						cylindrical shaft										
		1.99.03115452	1.99.03115454	1.99.0310800	1.99.0310645	1.99.03109000	1.99.03109452	1.99.0311245	1.99.03215452	1.99.03215454	1.99.0210645	1.99.02109000	1.99.02109452	1.99.0211245	1.99.02112451	1.99.02115000	1.99.02115452	1.99.02115454		
Slot	Description	drill-Ø chaf. x45° shaft-Ø	15.25 1.5 MK	15.25 3.5 MK	6/8.5 -	6.2 2.0	9.2 -	9.2 1.5	12.2 2.0	15.25 1.5	15.25 3.5	6.2 2.0	9.2 -	9.2 1.5	12.2 2.0	12.2 1.0	15.25 -	15.25 1.5	15.25 3.5	
<b>Cross bushing</b>																				
H F E	Standard						●													
H F E	for profile 20x20, soft							●									●			
H F E	Standard		●								●								●	●
H F E	for profile • 30x30, soft • 30x150			●																●
H F E	for profile 40x40, 2E 45°, LP			●																●
H F E	for ST-Connector, profile 30x150		●	●																●
H F E	for SE-Connector																			●
H F E	for ST-Connector		●																	●
H F E	for ST-Connector type 4																			●
<b>Anchor</b>																				
H F E	for connector, parallel						●													●
H F E	for connector, parallel																			●
H F E	for connector, miter, hinge						●													



**Drill jigs for profiles with H-slots**



Drill jig with setscrew

**Application**

- Tools for precise machining of connection bore
- for drilling machine: - drill jig  
- drill
  - for milling machine: - milling cutter
  - the drill jig is located and fastened in the profile slot
  - suitable for any profile angle cut



Drill jig with clamping lever

**Technical data**

- Base body:
- material: aluminium
  - surface: neutral anodised
- Drill bush:
- material: steel
  - surface: hardened and polished

**Drill jig with setscrew**

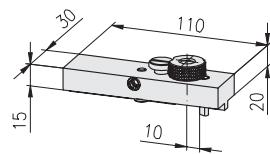

Description	Weight	Article-No.
Drill jig H with setscrew	189 g	1.99.01011
Single parts		
Base body	120 g	1.99.01012-01
Drill bush for cross bushing, Ø9.2	50 g	1.99.01012-03
Safety screw for drill bush, M6×4	6 g	1.99.01012-04
Stop pin	2 g	1.99.01012-05
Connector	11 g	1.20.3/2H5

Accessories		
Drill bush for parallel-anchor, Ø6.2	43 g	1.99.01012-02

**Drill jig with clamping lever**

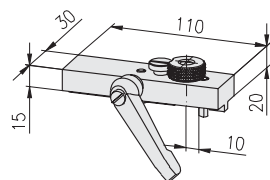

Description	Weight	Article-No.
Drill jig H with clamping lever	225 g	1.99.01012
Single parts		
Base body	120 g	1.99.01012-01
Drill bush for cross bushing, Ø9.2	50 g	1.99.01012-03
Safety screw for drill bush, M6×4	6 g	1.99.01012-04
Stop pin	2 g	1.99.01012-05
Connector	11 g	1.20.3/2H5
Clamping lever 65, for connector, M6×20	36 g	1.29.650620

Accessories		
Drill bush for parallel-anchor, Ø6.2	43 g	1.99.01012-02

**Tools**  
for profiles with H-slots

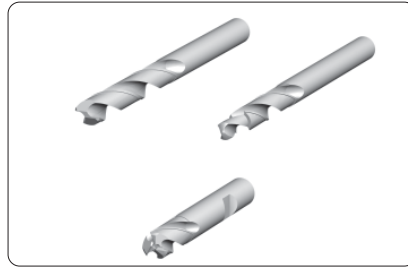

Drill, Milling cutter

**Comments**

Selection range ↗ 326

**Milling cutter**

- parallel-anchor
- cross bushing

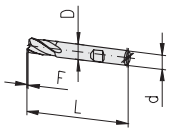

**Technical data**

material: HSS  
3 cutting edges  
cutting geometry for aluminium machining  
off-centre cutting edges

Description	D	L	F	d	Weight	Article-No.
Milling cutter f. par.-anchor	Ø6.2	60	2.0×45°	10	13 g	1.99.0210645
Milling cutter f. cross bush.	Ø9.2	70	without	10	34 g	1.99.0210900
Milling cutter f. cross bush.	Ø9.2	70	1.5×45°	10	34 g	1.99.02109452

**Drill**

- parallel-anchor
- cross bushing

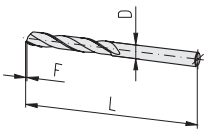

**Technical data**

material: HSS  
2 cutting edges  
cutting geometry for aluminium machining  
off-centre cutting edges

Description	D	L	F	Weight	Article-No.
Drill for parallel-anchor	Ø6.2	100	2.0×45°	16 g	1.99.0310645
Drill for cross bushing	Ø9.2	120	without	43 g	1.99.03109000
Drill for cross bushing	Ø9.2	120	1.5×45°	43 g	1.99.03109452

**Drill**

for miter anchor

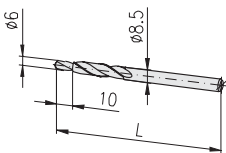

**Technical data**

material: HSS  
2 cutting edges  
cutting geometry for aluminium machining

**Application**

To drill core hole

**Comments**

Machining instruction ↗ 91, 1.2A

Description	D	L	Weight	Article-No.
Drill for miter anchor	Ø8.5	120	34 g	1.99.0310800

**Drill jigs**  
for profiles with F- and E-slots

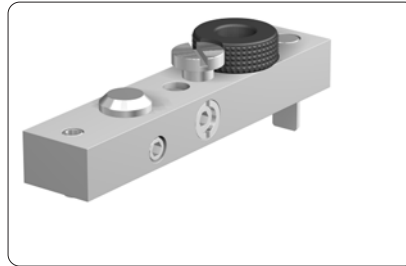

Drill jig with setscrew

**Application**

Tools for precise machining of connection bore

- for drilling machine: - drill jig  
- drill
- for milling machine: - milling cutter
- the drill jig is located and fastened in the profile slot
- suitable for any profile angle cut

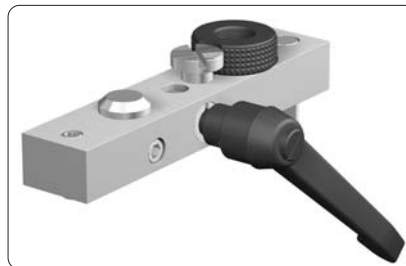

Drill jig with clamping lever

**Technical data**

Base body:

- material: aluminium
- surface: neutral anodised

Drill bush:

- material: steel
- surface: hardened and polished

**Drill jig**  
with setscrew

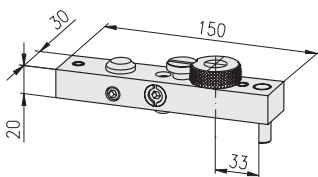

Description	Weight	Article-No.
Drill jig FE with setscrew	375 g	1.99.01111
<b>Single parts</b>		
Base body	188 g	1.99.01112-01
Drill bush for cross bushing, Ø15.25	105 g	1.99.01112-03
Safety screw for drill bush, M8×5.5	11 g	1.99.01112-04
Stop pin	19 g	1.99.01112-05
Setscrew for stop pin	2 g	1.99.01112-06
Connector, parallel-high	30 g	1.21.3/2F5
Anchor	20 g	1.21.A2E5

**Accessories**

Drill bush for parallel-anchor, Ø12.2	90 g	1.99.01112-02
---------------------------------------	------	---------------

**Drill jig**  
with clamping lever

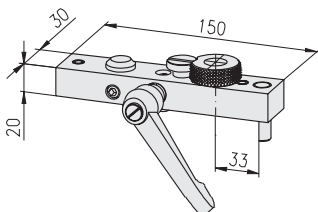

Description	Weight	Article-No.
Drill jig FE with clamping lever	438 g	1.99.01112
<b>Single parts</b>		
Base body	188 g	1.99.01112-01
Drill bush for cross bushing, Ø15.25	105 g	1.99.01112-03
Safety screw for drill bush, M8×5.5	11 g	1.99.01112-04
Stop pin	19 g	1.99.01112-05
Setscrew for stop pin	2 g	1.99.01112-06
Connector, parallel-high	30 g	1.21.3/2F5
Anchor	20 g	1.21.A2E5
Clamping lever 80, for connector, M10×20	63 g	1.29.801020

**Accessories**

Drill bush for parallel-anchor, Ø12.2	90 g	1.99.01112-02
---------------------------------------	------	---------------

**Tools**  
for profiles with F- and E-slots

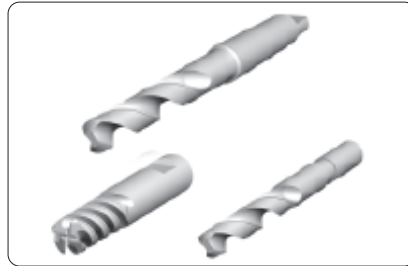

Drill, Milling cutter

**Comments**  
Selection range ↗ 326

**Milling cutter**

- for • parallel-anchor
- cross bushing

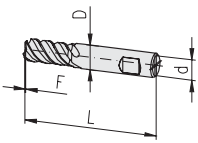

**Technical data**

material: HSS  
4 cutting edges  
cutting geometry for aluminium machining  
off-centre cutting edges

Description	D	L	F	d	Weight	Article-No.
Milling cutter f. par.-anchor	Ø12.2	85	2×45°	Ø12	59 g	1.99.0211245
Milling cutter f. cr. bush. ST, 4	Ø12.2	83	1×45°	Ø12	60 g	1.99.02112451
Milling cutter f. cross bush. SE	Ø15.2	93	without	Ø16	116 g	1.99.02115000
Milling cutter f. cross bush.	Ø15.2	93	1.5×45°	Ø16	116 g	1.99.02115452

**Drill**

for parallel-anchor

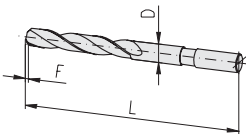

**Technical data**

material: HSS  
2 cutting edges  
cutting geometry for aluminium machining  
off-centre cutting edges

Description	D	L	F	Weight	Article-No.
Drill for parallel-anchor	Ø12.2	147	2×45°	93 g	1.99.0311245

**Drill**

for cross bushing

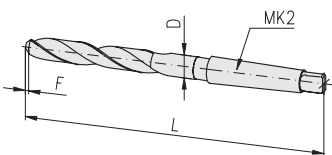

**Technical data**

material: HSS  
2 cutting edges  
cutting geometry for aluminium machining  
off-centre cutting edges

Description	D	L	F	Weight	Article-No.
Drill for cross bushing, MK2	Ø15.25	210	1.5×45°	224 g	1.99.03115452

**Drill**

for cross bushing

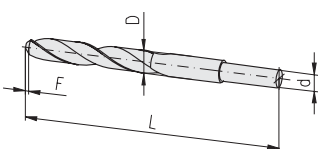

**Technical data**

material: HSS  
2 cutting edges  
cutting geometry for aluminium machining  
off-centre cutting edges

Description	D	L	F	d	Weight	Article-No.
Drill for cross bushing	Ø15.25	173	1.5×45°	Ø12	197 g	1.99.03215452

**Tools**  
for profiles with F- and E-slots

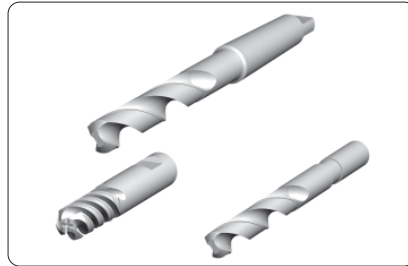

**Comments**  
Selection range ↔ 326

Drill, Milling cutter

**Milling cutter**  
for cross bushing

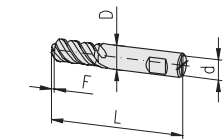

**Technical data**  
material: HSS  
4 cutting edges  
cutting geometry for aluminium machining  
off-centre cutting edges

Description	D	L	F	d	Weight	Article-No.
Milling cutter f. cross bush.	Ø15.2	93	4.0×45°	Ø16	116 g	1.99.02115454

**Drill**  
for cross bushing

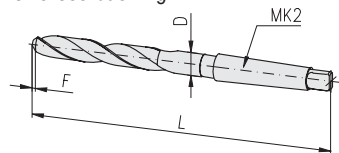

**Technical data**  
material: HSS  
2 cutting edges  
cutting geometry for aluminium machining  
off-centre cutting edges

Description	D	L	F	Weight	Article-No.
Drill for cross bushing, MK2	Ø15.25	210	4.0×45°	224 g	1.99.03115454

**Drill**  
for cross bushing

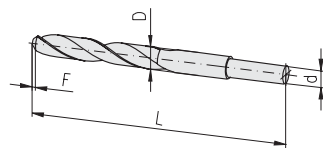

**Technical data**  
material: HSS  
2 cutting edges  
cutting geometry for aluminium machining  
off-centre cutting edges

Description	D	L	F	d	Weight	Article-No.
Drill for cross bushing	Ø15.25	180	4.0×45°	Ø12	197 g	1.99.03215454

**Screw taps  
for aluminium machining**

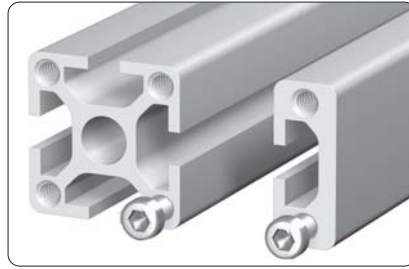

**Application**

Mounting threads in profile centre core hole  
Ø5 mm

**Screw tap**

M6

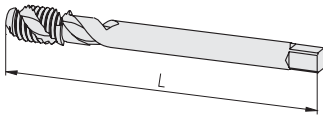

16 20 30 40 45 50 60

**Technical data**

material: HSS/E

machine threading tap:

- right hand cutting, 40° left spiral fluted
- enlarged chip flute
- 3-pitch thread start
- tolerance class: 6H

Description	G	L	Weight	Article-No.
Screw tap	M6	80	45.0 g	1.99.0406080

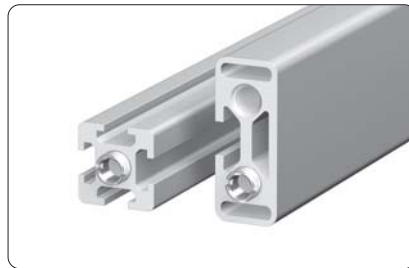

**Application**

Mounting threads in profile centre core hole  
Ø6.2 mm

**Screw tap**

M8

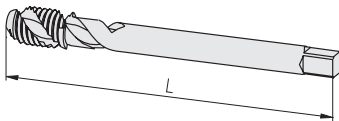

16 20 30 40 45 50 60

**Technical data**

material: HSS/E

machine threading tap:

- right hand cutting, 40° left spiral fluted
- enlarged chip flute
- 3-pitch thread start
- tolerance class: 6H

Description	G	L	Weight	Article-No.
Screw tap	M8	90	52.0 g	1.99.0408090

**Screw taps  
for aluminium machining**

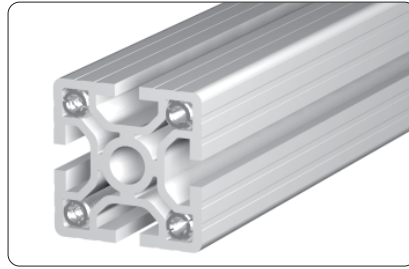

**Application**  
Fastening thread in hollow chambers of profiles PG 50

**Screw tap  
M12**

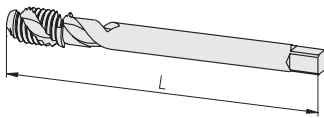

16 20 30 40 45 50 60

**Technical data**

- material: HSS/E  
machine threading tap:
- right hand cutting, 20° left spiral fluted
  - enlarged chip flute
  - 2-pitch thread start
  - tolerance class: 6H

Description	G	L	Weight	Article-No.
Screw tap	M12	110	65 g	1.99.0412110

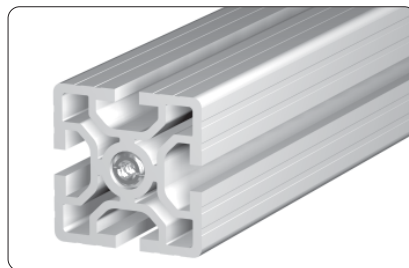

**Application**  
Mounting threads in profile centre core hole Ø12 mm

**Screw tap  
M14**

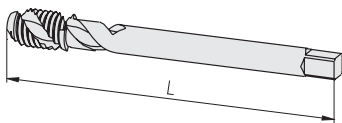

H F E

**Technical data**

- material: HSS/E  
machine threading tap:
- right hand cutting, 20° left spiral fluted
  - enlarged chip flute
  - 2-pitch thread start
  - tolerance class: 6H

Description	G	L	Weight	Article-No.
Screw tap	M14	110	75 g	1.99.0414110
Screw tap	M14	150	105 g	1.99.0414150

## MayTec Online Library

The online library is available on the MayTec Web Site at [www.maytec.de](http://www.maytec.de) in English and German.

Any number of parts can be selected while online and requested as either 2D drawings or 3D models. Once the parts have been chosen, the drawings will be supplied in the original file format of the selected CAD package or in any standard interface format. The requested files are supplied to the user as an Email attachment.

### System requirements

- Internet access
- Email account

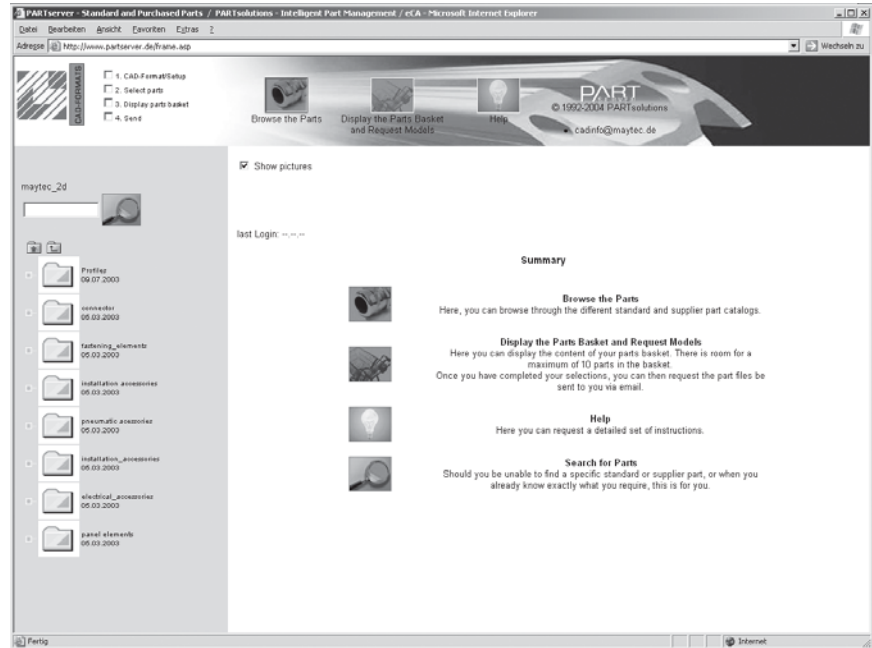

### Description

- Suitable for all 2D and 3D AutoCAD Systems.
- Provides 2D drawings and 3D models in original file format for all common CAD packages.
- 3D preview allows the simple selection of required parts.
- Profile drawings can be provided in any length.
- Includes all products in the MayTec profile catalogue.
- No limit on the number of selected parts to be provided during any session.
- All 2D drawings and 3D models are supplied as email attachments.

Price: free of charges





**MayTec 3D Library with B&W Profiles**

**System requirements**

- PRO/Engineer 2001 or Wildfire
- B&W Profiles Advanced

The MayTec 3D library has been designed for use in conjunction with PRO/Engineer and B&W Profiles software.

B&W Profiles provides the operator with a user friendly interface for the simulated assembly of profiles, connectors and accessories. The software is also designed to support the joining of these profiles and the implementation of the MayTec connector system. The design of frames and building elements using the MayTec profile system with the B&W software is thereby greatly simplified and becomes much more cost-effective.

Another important feature of the software is the automatic generation of complete parts lists with machining codes and MayTec part numbers. The parts list can be exported automatically into the MayTec calculation software if required.

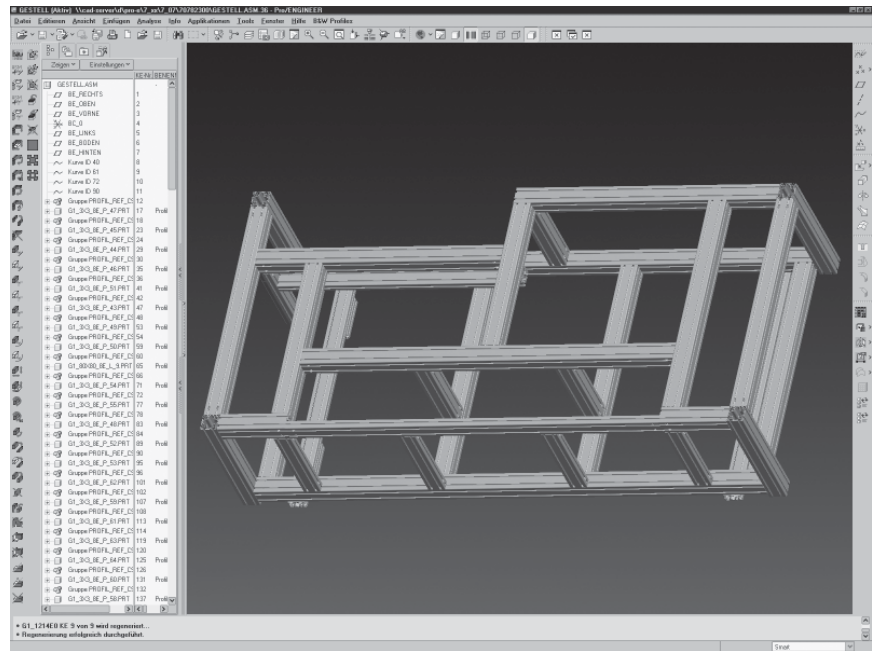

**Description**

- 3D software for PRO/Engineer in conjunction with B&W Profiles.
- Simplified assembly of profiles using 3D sketching on elements or between points.
- Rational definition of profile nodes (corners, T-joints, parallel joins, etc.) including connector drilling holes.
- Rotating, moving and swapping of profiles can be done at any time without the need to regenerate the drawings.
- Automatic generation of parts lists with MayTec article numbers and machining codes.
- Automatic export of all parts lists to the MayTec calculation software.
- Includes all products in the MayTec profile catalogue.

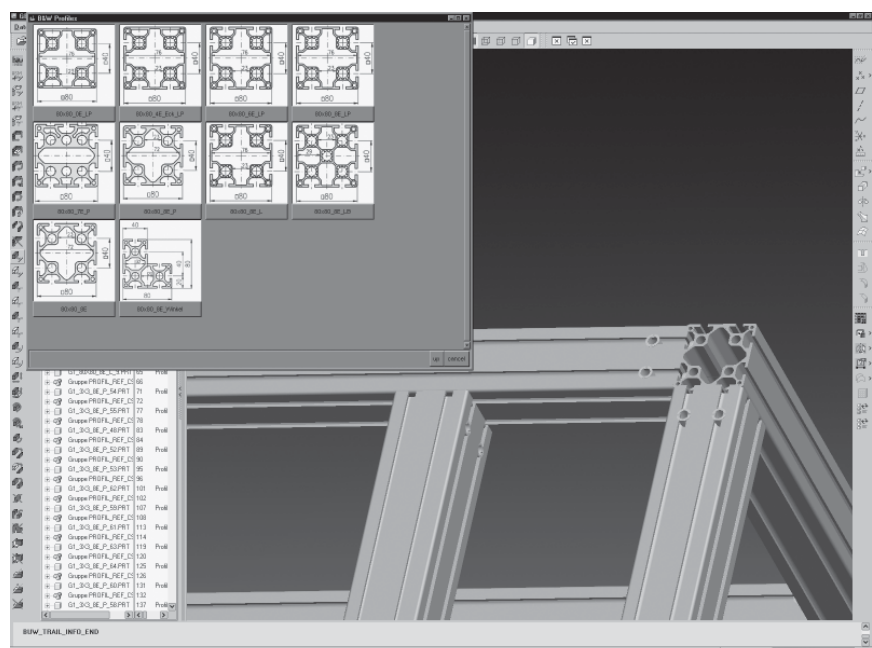

**Price: on request**  
(dependent on existing CAD equipment)

A

**Metric and English Conversion Table**

<b>Linear Measure</b>					
1 km	=	0.6214 mi	1 mi	=	1.61 km
1 m	=	0.0006214 mi	1 mi	=	1,610 m
1 m	=	3.28 ft	1 ft	=	0.305 m
1 cm	=	0.3937 in	1 in	=	2.54 cm
1 mm	=	0.03937 in	1 in	=	25.4 mm

<b>Square Measure</b>					
1 km <sup>2</sup>	=	0.3861 mi <sup>2</sup>	1 mi <sup>2</sup>	=	2.59 km <sup>2</sup>
1 m <sup>2</sup>	=	10.76 ft <sup>2</sup>	1 ft <sup>2</sup>	=	0.093 m <sup>2</sup>
1 cm <sup>2</sup>	=	0.155 in <sup>2</sup>	1 in <sup>2</sup>	=	0.65 cm <sup>2</sup>
1 mm <sup>2</sup>	=	0.00155 in <sup>2</sup>	1 in <sup>2</sup>	=	845.2 mm <sup>2</sup>

<b>Weight Measure</b>					
1 kg	=	2.2 lbs	1 lb	=	0.455 kg
1 kg	=	35.274 ozs	1 oz	=	0.028 kg

<b>Force Measure</b>					
1 Newton (N)	=	0.225 lbs	1 lb	=	4.448 N
1 daN	=	2.2 lbs	1 lb	=	0.455 daN
1 kg Force	=	9.8 Newton (N)	1 N	=	0.102 kg Force
1 Kilopound	=	9.5 Newton (N)	1 N	=	0.105 Kilopound
1 Pound/Inch	=	175.127 Newton/Meter	1 N/m	=	0.0057 Pound/Inch
1 Pound/Foot	=	14.59 Newton/Meter	1 N/m	=	0.0685 Pound/Foot

<b>Pressure Measure</b>					
1 Bar	=	14.5 P.S.I.	1 P.S.I.	=	0.690 Bar
1 kg/m <sup>2</sup>	=	9.8 Newton/Meter <sup>2</sup>	1 N/m <sup>2</sup>	=	0.102 kg/m <sup>2</sup>
1 kg/m <sup>2</sup>	=	9.8 Pascal (Pa)	1 Pa	=	0.102 kg/m <sup>2</sup>
1 Kilonewton/Meter	=	0.145 P.S.I.	1 P.S.I.	=	6.897 KN/m <sup>2</sup>

<b>Other</b>					
1 in <sup>3</sup>	=	16.3871 cm <sup>3</sup>	1 cm <sup>3</sup>	=	0.0610 in <sup>3</sup>
1 in <sup>4</sup>	=	41.623 cm <sup>4</sup>	1 cm <sup>4</sup>	=	0.024 in <sup>4</sup>
1 lb/ft	=	1.4882 kg/m	1 kg/m	=	0.67195 lb/ft
1 Nm	=	8.858 inch-pounds	1 inch-pound	=	0.113 Nm

## Metric / U.S. Customary Unit Equivalents

Linear				
miles	× 1.6093	= kilometers (km)	× 0.6214	= miles
yards	× 0.9144	= meters (m)	× 1.0936	= yards
feet	× 0.3048	= meters (m)	× 3.281	= feet
inches	× 2.54	= centimeters (cm)	× 0.3937	= inches
inches	× 25.4	= millimeters (mm)	× 0.03937	= inches

Area				
miles <sup>2</sup>	× 2.59	= kilometers <sup>2</sup> (km <sup>2</sup> )	× 0.3861	= miles <sup>2</sup>
yards <sup>2</sup>	× 0.8361	= meters <sup>2</sup> (m <sup>2</sup> )	× 1.196	= yards <sup>2</sup>
inches <sup>2</sup>	× 6.452	= centimeters <sup>2</sup> (cm <sup>2</sup> )	× 0.155	= inches <sup>2</sup>
acres <sup>2</sup>	× 0.4047	= hectares <sup>2</sup> (10 <sup>4</sup> m <sup>2</sup> ) or (ha)	× 2.471	= acres <sup>2</sup>
feet <sup>2</sup>	× 0.0929	= meters <sup>2</sup> (m <sup>2</sup> )	× 10.764	= feet <sup>2</sup>

Mass				
ounces (av)	× 28.35	= grams (g)	× 0.03527	= ounces (av)
pounds (av)	× 0.4536	= kilograms (kg)	× 2.2046	= pounds (av)
tons (2000 lb)	× 907.18	= kilograms (kg)	× 0.001102	= tons (2000 lb)
tons (2000 lb)	× 0.90718	= metric tons (t)	× 1.1023	= tons (2000 lb)

Force				
ounces - f	× 0.278	= newtons (N)	× 3.597	= ounces - f
pounds - f	× 4.448	= newtons (N)	× 0.2248	= pounds - f
kilograms - f	× 9.807	= newtons (N)	× 0.10197	= kilograms - f

Thread	mm			inch		
	Outside dia	Core dia		Outside dia	Core dia	
metric		Bolt	Nut		Bolt	Nut
M4	4	3.141	3.242	0.15748	0.12362	0.12756
M5	5	4.019	4.134	0.19685	0.15827	0.16260
M6	6	4.773	4.917	0.23622	0.18779	0.19370
M8	8	6.466	6.647	0.31496	0.25472	0.26181
M10	10	8.160	8.376	0.39370	0.32126	0.32992
M12	12	9.853	10.106	0.47244	0.38779	0.39803
M14	14	11.546	11.835	0.55118	0.45827	0.46614
M16	16	13.546	13.835	0.62992	0.53346	0.54488

Thread	inch			mm		
	Outside dia	Core dia		Outside dia	Core dia	
UNF, NF / UNC, NC		Bolt	Nut		Bolt	Nut
8 - 32	0.16402	0.12571	0.13020	4.166	3.193	3.307
10 - 32	0.19000	0.15169	0.15618	4.826	3.853	3.967
1/4" - 20	0.25000	0.18870	0.19591	6.350	4.793	4.967
5/16" - 18	0.31252	0.24429	0.25240	7.938	6.205	6.411
3/8" - 16	0.37500	0.29831	0.30728	9.525	7.577	7.805
1/2" - 13	0.50000	0.40551	0.41669	12.700	10.300	10.584
9/16" - 12	0.56252	0.46031	0.47228	14.288	11.692	11.996
5/8" - 11	0.62500	0.51350	0.52661	15.875	13.043	13.376

19" profiles .....	55	Base angle .....	187
3D Library .....	335	Base feet .....	181, 182
<b>A</b>		Floor mounting sets .....	181, 185
Abbreviations .....	5	Profile mounting sets .....	186
Accessories .....	132	Base plates .....	204
Acrylic .....	320	Base profiles .....	50
Additional accessories .....	133, 221	Bayonet type connector .....	113
Adjustable tilt-feet .....	175	extension .....	115
anti-slip discs .....	179	Bending strength .....	66
cushion elements .....	179	Bent profiles .....	82
nuts .....	178	Block for cable binder .....	296
plates .....	176	Bores for parallel-connector .....	60
Single parts .....	175	Bullet catches .....	254
spindles .....	178	PA .....	255
Adjustable tilt-foot anti-slip discs .....	179	Button head screws .....	323
Adjustable tilt-foot cushion elements .....	179	<b>C</b>	
Adjustable tilt-foot nuts .....	178	Cable and hose clamp .....	295
Stainless steel .....	178	Cable binder .....	296
Steel .....	178	detachable .....	296
Adjustable tilt-foot plates .....	176	CAD Library .....	334
with mounting holes .....	177	Calculation formulas for polygons .....	124
without mounting holes .....	176	Carabine swivel .....	292
Adjustable tilt-foot plates with mounting holes .....	177	Carriage support profiles, F / E3-slot (plain) .....	48
GD-Zn .....	177	Castors .....	188
PA .....	177	Fixed castors .....	188
Stainless steel .....	177	Fixed castors with bolt hole .....	188
Adjustable tilt-foot plates without mounting holes .....	176	Fixed castors with fitting plate .....	188
GD-Zn .....	176	Locking castors .....	190
PA .....	176	Swivel castors .....	189
Stainless steel .....	176	Swivel castors lockable .....	189
Adjustable tilt-foot spindles .....	178	Swivel castors lockable with bolt hole .....	189
Stainless steel .....	178	Swivel castors with bolt hole .....	189
Steel .....	178	Swivel castors with fitting plate .....	189
Alu hinges .....	238	Threaded bolt for locking castor with center thread .....	191
heavy .....	240	Chipboards .....	318
Press-fit pins for alu hinges .....	239	Clamping connector 40E .....	117
Spacer .....	239	Clamping for guidance system .....	285
Type A .....	238	Clamping levers .....	131
Type B .....	238	Coding examples .....	62
Type C .....	239	for price group 1 .....	62
Alu hinges, heavy .....	240	for price group 2 .....	63
Alu-plastic composite panel .....	319	for price group 3 .....	64
Angle profiles .....	51	Combination profiles .....	152, 154
Angles .....	192	PVC .....	151
Angles 25×40 .....	192	Connection .....	128
Angles Alu .....	201	elements .....	128
Angles GD-Al .....	200	of 0-slot profiles .....	118
Angles GD-Zn .....	194	of MayTec with other profile systems .....	126
Angles PA .....	193	of profiles 40, round .....	124
Swivel angles .....	202	plates .....	207
Angular adjusting feet .....	180	with corner pieces .....	212
with adjusting screw .....	180	Connection elements .....	128
without adjusting screw .....	180	Anti-twist devices .....	129
Angular tolerance .....	66	Anti-twist devices for subsequent insertion .....	130
Anti-twist devices .....	129	Clamping levers .....	131
for subsequent insertion .....	130	Retaining plates .....	128
Approximate determination of deflection .....	67	Connection plates .....	207
<b>B</b>		Connection possibilities .....	118
Bar locks .....	266	for 0-slot profiles .....	118
Assembly accessories .....	268	for profiles 40, round .....	124
Lock mounting sets .....	269	Other profile systems .....	126
Olive installation sets .....	269	Special cases .....	125
Profile machining .....	267	Subsequent mounting of profiles .....	125
		Connection possibilities for 0-slot profiles .....	118

Connection with DIN-Screw .....	123	Connector - Cross bushings .....	99
Connection with screw-type connector .....	122	Drill dimensions for connector cross bushings .....	99
Connection with standard connector .....	119	Mounting variants .....	100
Connection possibilities for profiles 40, round .....	124	Connector - Drill dimensions .....	118
Calculation formulas for polygons .....	124	with radius covers .....	118
Connection System .....	83	without radius covers .....	118
Connection variants with screw-type connectors .....	92, 97	Connectors .....	89
Connector .....	91	Connector complete .....	101
Bayonet type connector .....	113	Cross bushings .....	99
Bayonet type connector extension .....	115	drill dimensions .....	118
Clamping connector 40E .....	117	Examples .....	85
Connector screw .....	98	Machining of profiles with core hole-Ø12 .....	93
Connector screw-self-cutting .....	98	Machining of profiles with core hole-Ø6 .....	91
Cross connector .....	116	Manufacture a connection .....	89
Extension .....	91, 95	Parallel connector .....	106
Extension / parallel connector .....	107	Special cases .....	106
Miter 90°-bent anchor l .....	96	types and materials .....	90
Miter 90°-bent anchor r .....	96	Connectors - Special cases .....	106
Miter 90°-hinge l + r .....	91, 96	Bayonet type connector .....	113
Miter-bent anchor l + r .....	96	Bayonet type connector extension .....	115
Miter-hinge l + r .....	91, 96	Clamping connector 40E .....	117
Oblique 90°-bent anchor .....	94	Connector screw self-cutting .....	112
Oblique 90°-bent anchor 90° .....	94	Cross connector .....	116
Oblique 90°-hinge .....	91, 94	Extension / parallel connector .....	107
Oblique-bent anchor l .....	93	SE-Connector .....	109
Oblique-bent anchor r .....	93	ST-Connector .....	110
Oblique-bent anchor standard l .....	93	ST-Connector with anchor, screw-type .....	111
Oblique-bent anchor standard r .....	94	Universal connector with knurled cross bushing .....	108
Oblique-cross-hinge .....	94	Conversion tables .....	336
Oblique-cross-hinge 90° .....	94	Metric / U.S. Customary Unit Equivalents .....	337
Oblique-hinge l + r .....	91, 93	Metric and English Conversion Table .....	336
Parallel-cross .....	91, 95	Corner elements .....	314
Parallel-high .....	91, 95	Corner element 33 for wire net mounting profile 33×10 ...	315
Parallel-high 90° .....	95	for wire net mounting profile .....	314
Parallel-square .....	91, 95	Corner pieces .....	210
Parallel-square 90° .....	95	45° .....	211
Screw-type front sided .....	92, 97	cubic .....	210, 213
Screw-type parallel-cross .....	92, 97	segment .....	213
Screw-type parallel-high .....	92, 97	segment, 2gang .....	213
Screw-type parallel-square .....	92, 97	spherical .....	211, 213
SE-Connector .....	109	Cover caps .....	164
Shifter .....	96	for profiles with core hole-Ø12 .....	165
Square head .....	93	for profiles with core hole-Ø6 .....	164
Standard .....	93	for profiles without core hole .....	164
Standard 90° .....	93	for screw bores .....	168
ST-Connector .....	110	for tubes .....	168
ST-Connector with anchor, screw-type .....	111	Ø48 for hand rail profile .....	166
Universal .....	91, 93	Cover plug .....	118, 167
Universal connector with knurled cross bushing .....	108	for connector bushings .....	167
Connector complete .....	101	domed .....	167
PG 20 .....	101, 102, 104	Cover profiles .....	149
PG 30 .....	102, 104	Alu .....	149
PG 40 .....	102, 104	PVC .....	149
PG 45 .....	103, 105	Cross bore .....	60
PG 50 .....	103, 105	Cross bushing .....	99
PG 60 .....	103, 105	bore for connector .....	60
Connector components .....	101	Cross connection plates .....	203
Anchor .....	101, 103	Cross connector .....	116
Cross bushing .....	101, 102	Cross section of slots .....	6
Setscrew .....	103	Cross-blocks for cable binder .....	296
Spring .....	103	C-track .....	52
Connector for .....		Cylinder locks .....	258
core hole-Ø 12 mm .....	102	flush .....	260
core hole-Ø 6 mm .....	101	with security latch .....	259
Connector screw self-cutting .....	112		
Connector selection .....	90		

<b>D</b>	
Deflection .....	67
Delivery length .....	65
Determination of deflection .....	67
Direction and Position .....	61
Distance washer .....	286
Door handle .....	265
Door knob .....	265
Double hinge .....	232
Drill dimensions for connector cross bushings .....	99
Drill jigs .....	327
for profiles with F- and E-slots .....	329
for profiles with H-slots .....	327
with clamping lever .....	327, 329
with setscrew .....	327, 329
Drills .....	328, 330
<b>E</b>	
E3-slot .....	6
E4-slot .....	6
Eco-Slides .....	287
Edge roller .....	278
Electrical accessories .....	134, 293
Electrical installation trunking .....	307, 311
accessories .....	307
E-trunking Alu, base profiles .....	56, 311
E-trunking Alu, end plates .....	313
E-trunking Alu, for clips .....	312
E-trunking Alu, lids .....	56, 312
E-trunking Alu, pre-cut lid .....	312
E-trunking Alu .....	307, 311
E-trunking Alu, end plates .....	313
E-trunking Alu, for clips .....	312
E-trunking Alu, pre-cut lid .....	312
E-trunking profiles .....	56
Base profiles .....	56
Cover profiles .....	56
Extension / parallel connector .....	107
Extruded profile as per DIN EN 12020-1 .....	65
Eye-bolt .....	209
<b>F</b>	
Fastening elements .....	132
Fastening plate 30×150 .....	208
Fixed castors .....	188
with bolt hole .....	188
with fitting plate .....	188
Flap-lock countersunk .....	260
Flatness of profile surfaces .....	65
Flatness tolerance .....	65
Flexure load .....	127
Floor levelling screw .....	172
Floor mounting plate .....	205
Floor plate .....	206
Framing profiles .....	156, 161
one piece .....	156
two pieces .....	161
Functional length .....	65
F-slot .....	6
<b>G</b>	
Grab handle profiles .....	51, 225
Grab handles .....	225
Grid, steel .....	322
Ground connections .....	294
Ground connector for potential equalisation .....	293
Guard locking device .....	300
Guidance system .....	284
Clamping for guidance system .....	285
Distance washer .....	286
Sliding blocks .....	285
T-Nut sliding blocks .....	286
Guide profile PVC .....	155
<b>H</b>	
Hand adjustable feet .....	173
Hand rail .....	76
Handle system .....	223
oval design .....	224
round design .....	223
Handles .....	221
light Alu .....	221
light PA .....	221
PA .....	222
PA with bore .....	222
PA with thread .....	222
Hanging bracket .....	291
Hinge profiles .....	53
1.5 mm .....	53
2.0 mm .....	53
3.0 mm .....	54
5.0 mm .....	53
Hinges .....	226, 231, 233
Alu hinges .....	238
Alu hinges, heavy .....	240
Double hinge .....	232
Lift-off hinges .....	227
Hollow profiles .....	50
<b>I</b>	
Index .....	338
Installation accessories .....	132, 149
Installation rings .....	297
<b>J</b>	
Joints .....	242
with clamping lever .....	242
without clamping lever .....	242
with /without clamping lever .....	244
Zn .....	244
Zn, with clamping lever .....	244
Zn, without clamping lever .....	244
<b>L</b>	
Latch lock .....	270
Levelling feet .....	172, 174
Levelling furniture foot .....	174
Lift-off hinges .....	227
Lock GD-Zn .....	257
Lock mounting set .....	269
with double beard key .....	269
with square key .....	269
Locking castors .....	190
with center thread .....	191
with plate .....	190
<b>M</b>	
Machining of profiles .....	91
with core hole-Ø12 .....	93
with core hole-Ø6 .....	91

with core hole-Ø6 for miter .....	91	Panel framing profile .....	52
Magnetic lock PA .....	256	Panel profiles 40, E3-slot, P .....	45
Makrolon .....	320	Parallel connector .....	106
MayTec 3D Library .....	335	Parallelism tolerance .....	66
MayTec connector with square head .....	85	Pneumatic .....	214
MayTec ground-connector for potential equalisation .....	85	90° connection sets .....	219
MayTec Online Library .....	334	accessories .....	214
MayTec Screw-type connector .....	85	connection plate sets .....	217
MayTec Standard-connector .....	85	connection plates .....	217
MayTec Universal-connector .....	85	end plate sets .....	215
Mechanical data .....	65	end plates .....	215
Metric / U.S. Customary Unit Equivalents .....	337	extension sets .....	218
Metric and English Conversion Table .....	336	Pneumatic accessories .....	133, 214, 220
Milling cutter .....	328, 330	Blanking plug .....	220
Mortise deadlocks .....	262	Reducing nipple .....	220
cases .....	263	Sealing ring .....	220
cases with lock .....	264	Polycarbonate .....	320
cases without lock .....	263	Potential equalisation .....	293
Door handle .....	265	Press in device for knurled cross bushing .....	324
Door knob .....	265	Press-fit pins for alu hinges .....	239
Installation sets .....	263	Press-fit threaded inserts .....	147
Installation sets with lock .....	264	without collar .....	148
Installation sets without lock .....	263	Price groups (1 -3) .....	59
Profile machining .....	262	Profile applications .....	72
Push pins .....	265	Bent profiles .....	82
Mounting adaptor for roller .....	277	Hand rail .....	76
Mounting blocks .....	245	Profile combinations .....	72
Distancing plate, thin .....	248	Profiles for cable guide .....	78
for subsequent insertion .....	247	Slot plates .....	73
GD-Zn .....	246	Special slits .....	72
screw-type .....	245	U-Profile 40 .....	77
Mounting clamp blocks .....	249	Profile combinations .....	72
for subsequent insertion .....	249	Profile group .....	12
SL .....	251	16 mm, E3-slot, P .....	15
Tool for mounting clamp block SL .....	251	16 mm, F-slot, P .....	12
Mounting instruction for screw-type connectors .....	92, 97	20 mm, F-slot, P .....	15
Mounting of connector in core hole .....	86	20 mm, H-slot, P .....	13
Mounting of connector in slot .....	87	30 mm, E4-slot, P .....	18
Mounting plates .....	206	30 mm, F-slot .....	34
Mounting set for 19" profile .....	298	30 mm, F-slot, P .....	16
Mounting sockets .....	316	40 mm, E3-slot .....	36
Mounting variation .....	119	40 mm, E3-slot, P .....	20
for high flexure load .....	120	45 mm, E4-slot .....	40
for high sliding load .....	121	45 mm, E4-slot, P .....	28
for profiles with 1 connector .....	119	50 mm, E4-slot .....	42
		50 mm, E4-slot, P .....	31
<b>N</b>		60 mm, E4-slot .....	44
Numerical key for articles .....	7	60 mm, E4-slot, P .....	32
		Profile machining .....	58
<b>O</b>		Bores for parallel-connector .....	60
Olive installation sets .....	269	Coding examples .....	62
Order description .....	58	Coding examples for special design .....	64
Order examples for special design .....	64	Cross bore .....	60
		Cross bushing bore for connector .....	60
<b>P</b>		Direction and Position .....	61
Panel elements .....	134, 314, 317	Order description .....	58
Acrylic .....	320	Price group 1-3 .....	59
Alu-plastic composite panel .....	319	Saw cut .....	59
Chipboards .....	318	Saw cut tolerance .....	59
Grid, steel .....	322	Summary .....	58
Makrolon .....	320	Thread .....	60
Polycarbonate .....	320	Profile pre-cut lids .....	50
Solid plastic panels .....	318	lid 30 .....	79
Wire net, Alu .....	321	lid 40 .....	80
Wire net, steel .....	321	lid 50 .....	81
		lid 120 .....	312

Profile selection range .....	68	Slide load .....	127
Profile tolerance .....	65	Slide-slot profiles PA .....	55
Profiles for cable guide .....	78	Sliding blocks .....	285
Slot distance 30 .....	79	Sliding doors .....	153
Slot distance 40 .....	80	construction types .....	153
Slot distance 50 .....	81	Sliding profiles .....	52
Profiles for pneumatic applications .....	214	Slot plates .....	73
Push pins .....	265	E-slot .....	73
<b>Q</b>		E-slot, slot distance 25 mm .....	75
Quick locks .....	252	E-slot, slot distance 50 mm .....	75
<b>R</b>		F-slot .....	73
Radius compensations .....	171	F-slot, slot distance 25 mm .....	74
Radius covers .....	169	F-slot, slot distance 50 mm .....	74
Rectangle 90° with one radius .....	170	Profile 30×100, 10F, plain .....	74
Rectangle 90° with two radii .....	170	Profile 30×100, 5E, 2F, plain .....	75
Rectangle with one radius .....	169	Profile 30×100, 9F, plain .....	74
Rectangle with two radii .....	170	Profile 30×150, 8E, plain .....	75
Square with one radius .....	169	Profile 30×150, 8F, plain .....	74
Square with two radii .....	170	Slot rollers .....	283
Reducing profiles PVC .....	150	Slot system .....	6
Register .....	1	E3-slot .....	6
Retaining plates .....	128	E4-slot .....	6
Rhomboid T-slot nuts .....	143	F-slot .....	6
Roller 29 .....	272	H-slot .....	6
Roller 39.5 .....	271	Solid plastic panels .....	318
Roller fastening sets .....	273	Spacer .....	239
A, double sided .....	274	Special cases .....	90
A, one sided .....	274	Special characters .....	5
type A .....	273	Special profiles .....	33, 50
type B .....	275	19" profiles .....	55
Roller fitting .....	279	Angle profiles .....	51
Roller profiles (plain) .....	47	Base profiles .....	50
Rubber cover-profiles .....	163	C-track .....	52
Runner .....	280	E-trunking profiles .....	56
for sliding suspended doors .....	281	Grab handle profiles .....	51
for suspended doors .....	280	Hinge profiles .....	53, 54
Stopper Type 1 for sliding suspended doors .....	282	Hollow profiles .....	50
Stopper Type 2 for sliding suspended doors .....	282	Panel framing profile .....	52
<b>S</b>		Profile pre-cut lids .....	50
Safety interlocking .....	301	Slide-slot profiles .....	55
Contact bracket-mounting .....	302	Sliding profiles .....	52
mountings .....	301	T-Slot profiles .....	54
Safety interlocking-mountings .....		Tubes .....	53
AZ 17 for sliding door .....	304	U-profiles .....	52
AZ 17 for swinging door .....	303	Wire net mounting profiles .....	51
for sliding door .....	302	Special slits .....	72
for swinging door .....	301	Sponge rubber round cords .....	158
with lock for swinging door .....	301	Spring-nuts .....	141
Safety switches .....	299	Stacking foot .....	187
AZ 17 .....	300	ST-Connector .....	110
Contact bracket-mounting .....	302	with anchor, screw-type .....	111
Guard locking devices AZM 170 .....	300	Straightness tolerance .....	65
Saw cut .....	59	Strength values for profile connections with MayTec-Connectors .....	127
Saw cut tolerance .....	59	Subject index .....	338
Screw taps .....	332	Subsequent mounting of profiles .....	125
Screw taps for aluminium machining .....	332	Summary .....	8, 86, 132, 326
Screws .....	323	Accessories .....	132
Button head screws .....	323	Connectors (with machining) .....	86
Sealing profile .....	160	Connectors (without machining) .....	88
SE-Connector .....	109	Profiles (plain) .....	8
Security latch .....	259	Profiles (with grooves) .....	9
Sensor brackets .....	306	Special profiles .....	11
		Special profiles (plain) .....	10
		Tools .....	326



Suspended doors .....	279	T-slot profiles .....	54
Alu C-track .....	279	PA .....	54
Bottom guide .....	280	Steel .....	54
Frame guide .....	280	Tubes .....	53
Roller fitting .....	279	Twin track guide for roller 29 .....	272
Rubber door stop .....	280	Twist tolerance .....	65
Runner .....	280	Tx screw driver .....	325
Stopper .....	280	Type of load .....	66
Suspended glider .....	292	<b>U</b>	
Swivel angles .....	202	Universal connector .....	91, 93
Swivel castors .....	189	for profile 30x150 .....	106
Swivel castors lockable .....	189	with knurled cross bushing .....	108
Symbols .....	5	U-Profile 40 .....	77
<b>T</b>		U-Profiles .....	52
T-Bolts .....	144	<b>V</b>	
Technical data .....	65	Vibration proof .....	83
Angular tolerance .....	66	<b>W</b>	
Approximate determination of deflection .....	67	Wedge profiles .....	157
Bending strength .....	66	Wire net mounting profiles .....	51
Deflection .....	67	Wire net profiles 30, F-slot, P .....	46
Delivery length .....	65	Wire net profiles 40, E3-slot, P .....	46
Extruded profile as per EN 12020 .....	65	Wire net, Alu .....	321
Flatness of profile surfaces .....	65	Wire net, steel .....	321
Flatness tolerance .....	65		
Functional length .....	65		
Mechanical data .....	65		
Parallelism tolerance .....	66		
Profile tolerance .....	65		
Straightness tolerance .....	65		
Twist tolerance .....	65		
Telescopic profiles, E3-slot (plain) .....	49		
Tension load .....	127		
Thread .....	60		
Threaded bolt for locking castor with center thread .....	191		
Threaded inserts .....	145		
Press-fit threaded inserts .....	147		
Press-fit threaded inserts w/o collar .....	148		
Threaded plates .....	135		
for subsequent insertion .....	136		
heavy .....	137		
T-Nut sliding blocks .....	286		
T-Nuts .....	138		
for subsequent insertion .....	138		
for subsequent insertion, with spring ball .....	138		
for subsequent insertion, with spring .....	139		
for subsequent insertion, with spring, 2xM4 .....	140		
for subsequent insertion, with spring, 2xM8 .....	139		
with spring .....	138		
Tools .....	134, 326		
Drill .....	328, 330		
Drill jigs .....	327, 329		
for anchors .....	326		
for cross bushings .....	326		
for profiles with F- and E-slots .....	330		
for profiles with H-slots .....	328		
Milling cutter .....	328, 330		
Press in device for knurled cross bushings .....	324		
Screw taps .....	332		
Special cases .....	331		
Summary .....	326		
Tx screw driver .....	325		
Torque tightening values for connector setscrew .....	127		
Torx .....	325		
T-slot nuts .....	142		

**Imprint**

Subject to technical modification.

All rights reserved.

Copying - also in parts - only allowed by written consent.

© MayTec Aluminium Systemtechnik GmbH, Germany, D - 85221 Dachau, 2006

# BEAT THE COMPETITION

## extreme - strong - dependable

The complex range of aluminium system profiles often prevents detailed critical comparisons.

The decision to purchase is therefore often made without detailed profit analysis.

Experienced designers and critical purchasers want to know the important details.

Which factors lead to the best technical and managerial decisions?

764 tests with 14 different systems prove what you need to know. ([www.maytec.de/competitioncomparison](http://www.maytec.de/competitioncomparison))

- ① How flexible can I design with the system?
- ② What equipment do I need to process the profile system?  
Is "on-site" service available when required?
- ③ How fast and simple is the system to assemble and disassemble?

Professionals win with the MayTec-System in all 3 disciplines.

### Flexible Design:

- with an Enormous Range
- with CAD & Online Library
- with Universal Connector System

**MayTec** VARIETY:  
OVER 200 PROFILES

### Economical Processing:

- with Simple Handling
- with Minimal Processing Times
- with Common Components

**MayTec** LEADS  
IN ALL DISCIPLINES

### Faster Assembly:

- with Simple Assembly Steps
- with Superior Stability
- with Good Access

**MayTec** ASSEMBLY TIME:  
5 SEC.

### "On-Site" Service:

- with Professional Advice
- with Professional Processing
- with Immediate Delivery

**MayTec** SERVICE:  
WORLD WIDE  
OVER 60 DISTRIBUTORS



MayTec GmbH plant in Dachau



Small parts store



Stock of aluminium profiles

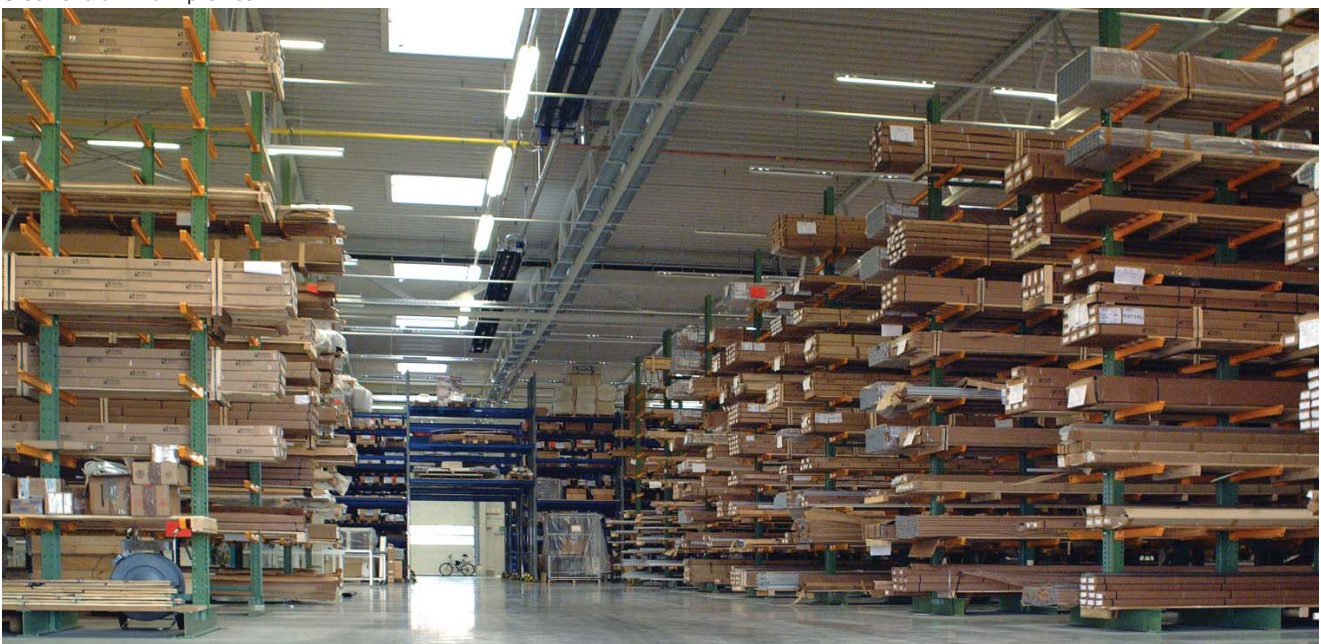

The key...

to success

extreme  
strong  
dependable

#### **Australia**

**MayTec Australia P/L**  
Unit 1, 8 Prosperity Parade  
Warriewood, NSW 2102

country code: +61  
phone (0) 2 / 9999 0890  
fax (0) 2 / 9979 8703  
e-mail: [info@maytec.com.au](mailto:info@maytec.com.au)  
<http://www.maytec.com.au>

#### **Germany**

**MayTec Aluminium**  
Systemtechnik GmbH  
Kopernikusstraße 20  
D - 85221 Dachau

country code: +49  
phone (0) 8131 / 33 36 - 0  
fax (0) 8131 / 33 36 - 119  
e-mail: [mail@maytec.de](mailto:mail@maytec.de)  
<http://www.maytec.de>

#### **USA**

**MayTec Inc.**  
1625 Dundee Ave., Unit E-F  
Elgin, IL 60120

country code: +1  
phone 847 - 429 - 0321  
fax 847 - 429 - 0460  
e-mail: [mail@maytecinc.com](mailto:mail@maytecinc.com)  
<http://www.maytecinc.com>

Your professional partner