

## Prístrojové kolesá série 372, 372B s kolesami PUA /nosnosť 80 kg/

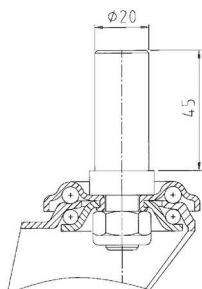

Upínanie na hladký čap Ø 20x45  
označenie - 372

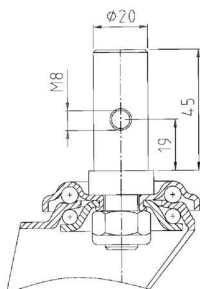

Upínanie na hladký čap Ø 20x45  
s priečnym otvorom  
označenie - 372.....H1











Otočná vidlica lisovaná z ocelového plechu, pozinkovaná, s dvojitým guľíkovým vencom v smerovej otoči, os kolesa zaistená skrutkou

Gehäuse aus Stahlblech, verzinkt-chromatisiert, mit zweireihigem Kugelkranz im Gabelkopf

Housing made of pressed steel zinc-chromatised, double ball bearing swivel head













102

Otočné koleso Lenkrolle Swivel castor								
372 PUA-G075	075	25		20	45	32	97	80
372 PUA-G100	100	25		20	45	42	127	80



103

Otočné koleso s brzdou kolesa Rad-feststeller Wheel brake								
372B PUA-G075	075	25		20	45	32	97	80
372B PUA-G100	100	25		20	45	42	127	80

## Prístrojové kolesá série 322, 322B s kolesami PUA

/nosnosť 80 kg/

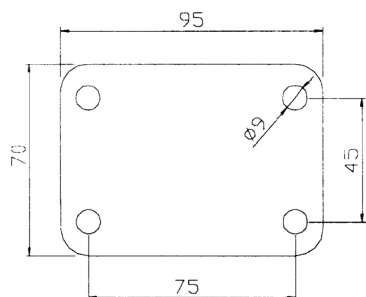

Upevňovacia príruha štvorhranná-typ P3  
na vidlice série 322,332

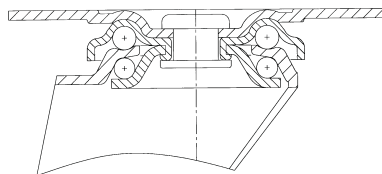

Otočná vidlica typ 322



Otočná vidlica lisovaná z oceleového plechu, pozinkovaná, s dvojitým guľíkovým vencom v smerovej otoči, os kolesa zaistená skrutkou

Gehäuse aus Stahlblech, verzinkt-chromatisiert, mit zweireihigem Kugelkranz im Gabelkopf

Housing made of pressed steel zinc-chromatised, double ball bearing swivel head













104

Otočné koleso Lenkrolle Swivel castor									
322 PUA-G075	075	25		95x70	75x45	9	32	99	80
322 PUA-G100	100	25		95x70	75x45	9	32	130	80













105

Otočné koleso s brzdou kolesa Rad-feststeller Wheel brake									
322B PUA-G075	075	25		95x70	75x45	9	32	99	80
322B PUA-G100	100	25		95x70	75x45	9	32	130	80



106

Pevné koleso Bockrolle Fixed castor									
332 PUA-G075	075	25		95x70	75x45	9	-	99	80
332 PUA-G100	100	25		95x70	75x45	9	-	130	80

## Samostatné kolesá - séria PUJ

/nosnosť 150-160 kg/











107

Disk kolesa z polyamidu, s polyuretánovou obručou /Shore A98/, ložisko guľičkové /g/

Polyamid Räder, mit Polyurethan -Lauffläche, Kugellager /g/

Polyamide wheel with polyurethan tread, ball bearings /g/

Samostatné koleso Rad Wheel						 kg
PUJ-g100/8 Z	100	32		8,2	36	150
PUJ-g100/8 Z*	125	32		8,2	36	160

\*Zahájenie výroby na predaj: február 2005

Kolesá s guľičkovým ložiskom

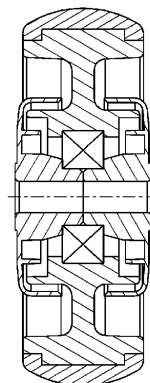

Označenie: PUJ-g...Z

## Prístrojové kolesá série 353,353F s kolesami PUJ /nosnosť 100 kg/

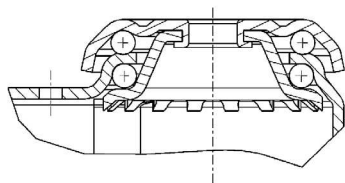
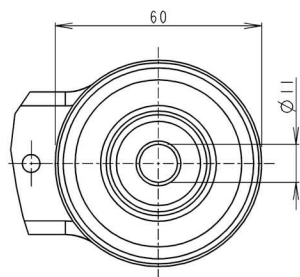

Otočná vidlica lisovaná z ocelového plechu, pozinkovaná, s dvojším guľičkovým vencom v smerevej otoči, os kolesa zaistená skrutkou

Gehäuse aus Stahlblech, verzinkt-chromatisiert, mit zweireihigem Kugelkranz im Gabelkopf

Housing made of pressed steel zinc-chromatised, double ball bearing swivel head

Upevnenie na stredový otvor  $\varnothing 11$   
na otočné vidlice série 353, 353F

Otočná vidlica typ 353



108

Otočné koleso Lenkrolle Swivel castor							
353 PUJ-g100 Z	100	32		11	38	135	100
353 PUJ-g125 Z*	125	32		11	40	160	100



109

Otočné koleso s total brzdou Total-feststeller Total lock							
353F PUJ-g100 Z	100	32		11	38	135	100
353F PUJ-g125 Z*	125	32		11	40	160	100

## Prístrojové kolesá série 303 s kolesami PUJ /nosnosť 100 kg/

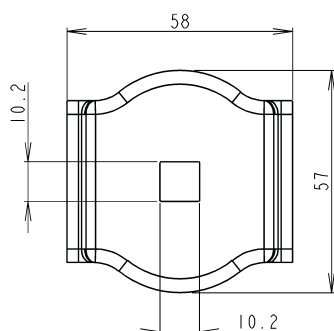

Upevnenie na stredový otvor  $\varnothing 10,2$   
na pevných vidliciach série 303



110

Pevné koleso Bockrolle Fixed castor							
303 PUJ-g100 Z	100	32		10,2	-	135	100
303 PUJ-g125 Z*	125	32		10,2	-	160	100

\*Zahájenie výroby na predaj: február 2005

## Prístrojové kolesá série 373,373F s kolesamPUJ /nosnosť 100 kg/

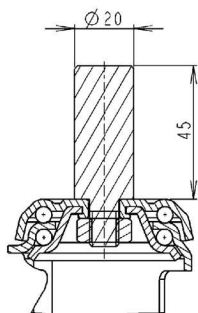

Upínanie na hladký čap Ø 20x45  
označenie - 373

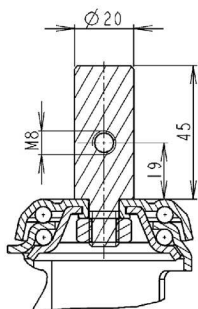

Upínanie na hladký čap Ø 20x45  
s priečnym otvorom  
označenie - 373.....H1











Otočná vidlica lisovaná z oceleového plechu, pozinkovaná, s dvojitým guľičkovým vencom v smerovej otoči, os kolesa zaistená skrutkou

Gehäuse aus Stahlblech, verzinkt-chromatisiert, mit zweireihigem Kugelkranz im Gabelkopf

Housing made of pressed steel zinc-chromatised, double ball bearing swivel head













111

Otočné koleso Lenkrolle Swivel castor								 kg
373 PUJ-g100 Z	100	32		20	45	38	135	100
373 PUJ-g125 Z*	125	32		20	45	40	160	100



112

Otočné koleso s total brzdou Total-feststeller Total lock								 kg
373F PUJ-g100 Z	100	32		20	45	38	135	100
373F PUJ-g125 Z*	125	32		20	45	40	160	100

\* Zahájenie výroby a predaja: február 2005

## Prístrojové kolesá série 323, 323F, 383 s kolesami PUJ /nosnosť 100 kg/

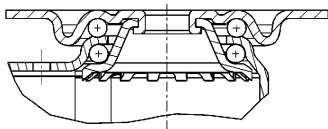
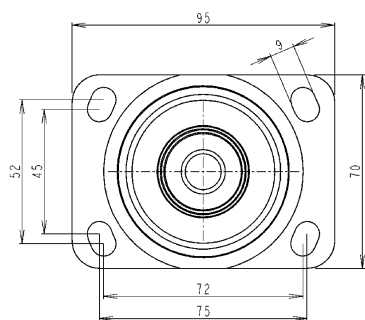

Otočná vidlica lisovaná z ocelového plechu, pozinkovaná, s dvojitým guľičkovým vencom v smerovej otoči, os kolesa zaistená skrutkou











Gehäuse aus Stahlblech, verzinkt-chromatisiert, mit zweireihigem Kugelkranz im Gabelkopf

Housing made of pressed steel zinc-chromatised, double ball bearing swivel head

Upevňovacia príruha štvorhranná -typ P33 Otočná vidlica typ 323  
na vidlice série 323, 323F, 383













113

Otočné koleso Lenkrolle Swivel castor									
323 PUJ-g100 Z	100	32		95x70	75/72x52/45	9	38	135	100
323 PUJ-g125 Z*	125	32		95x70	75/72x52/45	9	40	160	100







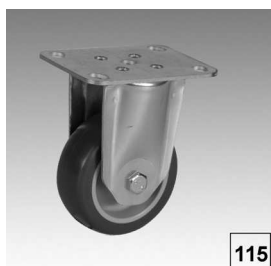





114

Otočné koleso s total brzdou Total-feststeller Total lock									
323F PUJ-g100 Z	100	32		95x70	75/72x52/45	9	38	135	100
323F PUJ-g125 Z*	125	32		95x70	75/72x52/45	9	40	160	100



115

Pevné koleso Bockrolle Fixed castor									
383 PUJ-g100 Z	100	32		95x70	75/72x52/45	9	-	135	100
383 PUJ-g125 Z*	125	32		95x70	75/72x52/45	9	-	160	100







\*Zahájenie výroby na predaj: február 2005

## NÁBYTKOVÉ DVOJKOLIESKA

/nosnosť 30-45 kg/









116

Otočné koleso Lenkrolle Swivel castor						
14 ON-040 P /37x37/	040	38	37x37	25x25	59	30
14 ON-050 P /50x50/	050	52	50x50	38x38	64	45
14 ON-050 + P /42x42/	050	55	42x42	32x32	70	45









117

Otočné koleso s brzdou kolesa Rad-feststeller Wheel brake						
14 ON-050 B + P /42x42/	050	55	42x42	32x32	70	45









118

Otočné koleso Lenkrolle Swivel castor						
14 ON-050š + P /42x42/	050	55	42x42	32x32	70	45



119







Otočné koleso Lenkrolle Swivel castor						
14 ON-040 TZ /M8x15/	040	38	M8	15	53	30
14 ON-040 H /8x28/	040	38	8	28	46	30
14 ON-040 TV /8x26/	040	38	8	26	46	30
14 ON-050 H /10x25/	050	52	10	25	57	45
14 ON-050 H /11x21/	050	52	11	21	61	45
14 ON-050 TZ /M10x15/	050	52	M10	15	66	45
14 ON-050+TZ /M8x16/	050	55	M8	16	64	45
14 ON-050 +H /8x28/	050	52	8	28	59	45

## Nábytkové dvojkoleska

/nosnosť 30-45 kg/







**120**

Otočné koleso s brzdou kolesa  
Rad-feststeller  
Wheel brake

						
14 ON-050 B+TZ /M8x16/	050	55	M8	16	64	45
14 ON-050 B +H /8x28/	050	52	8	28	59	45

**121**

Otočné koleso  
Lenkrolle  
Swivel castor

						
14 ON-050š + H /10x20/	050	55	10	20	61	45
14 ON-050š + H /11x20/	050	55	11	20	61	45
14 ON-050š + H /10x31/	050	55	10	32	62	45
14 ON-050š + TZ /M8x16/	050	55	M8	16	64	45
14 ON-050š + H /8x28/	050	52	8	28	59	45



### III. TRANSPORTNÉ KOLESÁ ROLLEN FÜR TRANSPORTGERATE, CASTORS FOR MATERIAL

#### Samostatné kolesá - séria XB /nosnosť 90-385 kg/



Disk kolesa z oceleového plechu, pozinkovaný, behúň - štandardná celogumová obruč /tvrdosť Shore A 80 +/-5/, čiernej farby /č/, ložisko ihlové /V/, guľičkové /G/

Stahlscheibenräder mit Vollgummi-Reifen, Gummiqualitäten schwarz /č/ Ausführung: verzinkt-chromatiert, mit Rollenlager /V/, Kugellager /G/

Steel disc wheels with solid rubber tyre black /č/, finish: zinc-chromatized, with roller bearing /V/, ball bearing /G/

Samostatné koleso Rad Wheel							
				L	L1	kg	
XB-V100/15č	100	38		15	43	-	90
XB-V125/15č	125	38		15	43	-	100
XB-V160/20č	160	45		20	59	-	205
XB-G160/12č	160	45		12	61	-	205
XB-G160/17č	160	45		17	59	55	205
XB-V200/20č	200	50		20	59	-	205
XB-G200/12č	200	50		12	61	-	205
XB-G200/17č	200	50		17	59	55	205
XB-V250/25č	250	70		25	78.5	-	295
XB-V280/25č	280	70		25	78.5	-	385

#### DOPLNKY

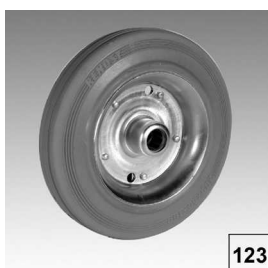

šedá gumová obruč



antistatická šedá gumová obruč

DOPLNKY	Dodatok ku obj. č.	Dodávané v Ø kolies
šedá gumová obruč	...š	u všetkých priemerov
antistatická šedá gumová obruč	...Antistatic-š	u kolies s guľičkovým ložiskom

Kolesá s ihlovým ložiskom

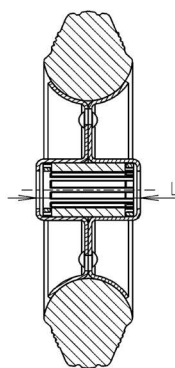

Označenie: XB-V...

Kolesá s guľičkovým ložiskom

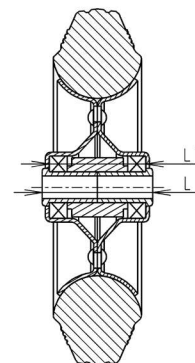

Označenie: XB-G...

## Transportné kolesá série 422,422B,432,623,623F,623T,633,628,638 s kolesami XB /nosnosť 90-320 kg/

### Upevňovacie príruby štvorhranné

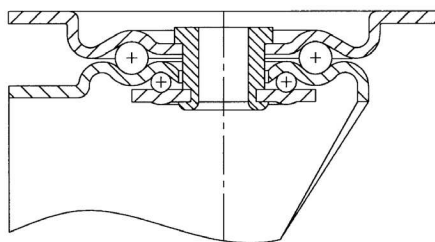
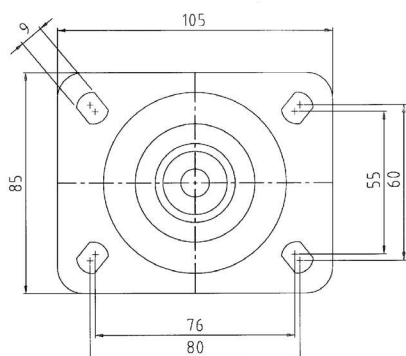

Otočná vidlica z ocelového plechu, pozinkovaná, s dvojitým guľičkovým vencom v smerovej otoči, os kolesa zaistená skrutkou

Gehäuse aus Stahlblech, verzinkt-chromatisiert, mit zweireihigem Kugelkranz im Gabelkopf

Housing made of pressed steel zinc-chromatised, double ball bearing swivel head

Typ P4 - na kolesá série 422,432

otočná vidlica typ 422

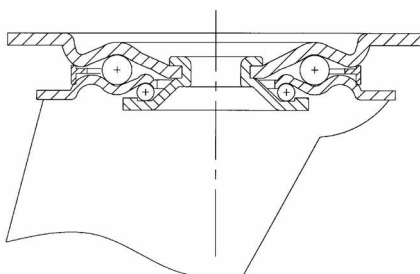
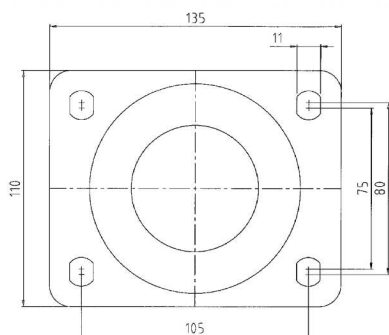

Typ P6 - na kolesá série 623,633

otočná vidlica typ 623

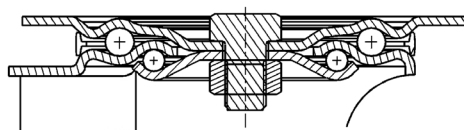
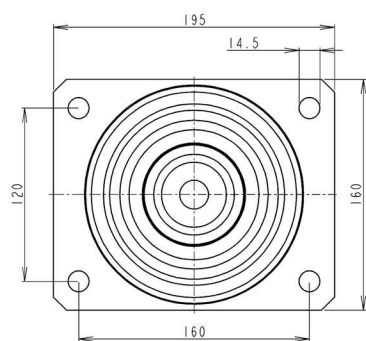

















Typ P8 - na kolesá série 628,638

















otočná vidlica typ 628













125

Otočné koleso Lenkrolle Swivel castor									
422 XB-V100č	100	38		105x85	80x60	9	39	128	90
422 XB-V125č	125	38		105x85	80x60	9	44	151	100
623 XB-V160č	160	45		135x110	105x80/75	11	49	201	205
623 XB-G160č	160	45		135x110	105x80/75	11	49	201	205
623 XB-V200č	200	50		135x110	105x80/75	11	55	240	205
623 XB-G200č	200	50		135x110	105x80/75	11	55	240	205
628 XB-V250č	250	70		195x160	160x120	14,5	76	301	295
628 XB-V280č	280	70		195x160	160x120	14,5	76	315	320













**126**

Pevné koleso Bockrolle Fixed castor								
432 XB-V100č	100	38		105x85	80x60	9	128	90
432 XB-V125č	125	38		105x85	80x60	9	151	100
633 XB-V160č	160	45		135x110	105x80/75	11	201	205
633 XB-G160č	160	45		135x110	105x80/75	11	201	205
633 XB-V200č	200	50		135x110	105x80/75	11	240	205
633 XB-G200č	200	50		135x110	105x80/75	11	240	205
638 XB-V250č	250	70		195x160	160x120	14,5	301	295
638 XB-V280č	280	70		195x160	160x120	14,5	315	320









**127**

Otočné koleso s brzdou kolesa Rad-feststeller Wheel brake								
422B XB-V100č	100	38		105x85	80x60	9	39	128
422B XB-V125č	125	38		105x85	80x60	9	44	151

**128**

Otočné koleso s total brzdou Total-feststeller Total lock								
623F XB-V160č	160	45		135x110	105x80/75	11	49	201
623F XB-G160č	160	45		135x110	105x80/75	11	49	201
623F XB-V200č	200	50		135x110	105x80/75	11	55	240
623F XB-G200č	200	50		135x110	105x80/75	11	55	240

**129**

Otočné koleso s total brzdou Total-feststeller Total lock								
623T XB-V160č	160	45		135x110	105x80/75	11	49	201
623T XB-G160č	160	45		135x110	105x80/75	11	49	201
623T XB-V200č	200	50		135x110	105x80/75	11	55	240
623T XB-G200č	200	50		135x110	105x80/75	11	55	240

## Transportné kolesá série 452,452B,653,653F,653T s kolesami XB

/nosnosť 90-205 kg/

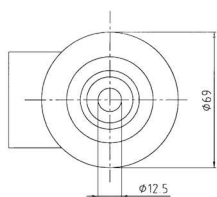

Upevnenie na stredový otvor  $\varnothing$  12,5  
na otočné vidlice série 452

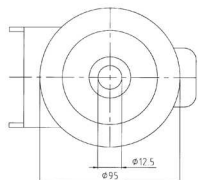

Upevnenie na stredový otvor  $\varnothing$  12,5  
na otočné vidlice série 653

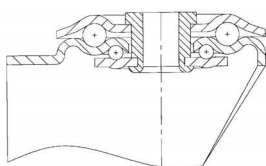

Otočná vidlica typ 452

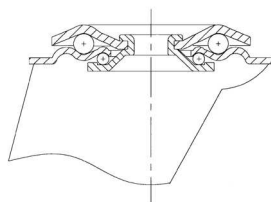

Otočná vidlica typ 653













Otočná vidlica z ocelového plechu, pozinkovaná,  
s dvojitým guľičkovým vncom v smerovej otoči,  
os kolesa zaistená skrutkou

Gehäuse aus Stahlblech, verzinkt-chromatisiert,  
mit zweireihigem Kugelkranz im Gabelkopf

Housing made of pressed steel zinc-chromatised,  
double ball bearing swivel head











130

Otočné koleso Lenkrolle Swivel castor							
452 XB-V100č	100	38		12,5	39	125	90
452 XB-V125č	125	38		12,5	44	147	100
653 XB-V160č	160	45		12,5	49	193	205
653 XB-G160č	160	45		12,5	49	193	205
653 XB-V200č	200	50		12,5	55	232	205
653 XB-G200č	200	50		12,5	55	232	205













131

Otočné koleso s brzdou kolesa Rad-feststeller Wheel brake							
452B XB-V100č	100	38		12,5	39	125	90
452B XB-V125č	125	38		12,5	44	147	100













132

Otočné koleso s total brzdou Total-feststeller Total lock							
653F XB-V160č	160	45		12,5	49	193	205
653F XB-G160č	160	45		12,5	49	193	205
653F XB-V200č	200	50		12,5	55	232	205
653F XB-G200č	200	50		12,5	55	232	205



133

Otočné koleso s total brzdou Total-feststeller Total lock							
653T XB-V160č	160	45		12,5	49	193	205
653T XB-G160č	160	45		12,5	49	193	205
653T XB-V200č	200	50		12,5	55	232	205
653T XB-G200č	200	50		12,5	55	232	205

## Transportné kolesá série 472,472B,673,673F,673T s kolesami XB /nosnosť 90-205 kg/

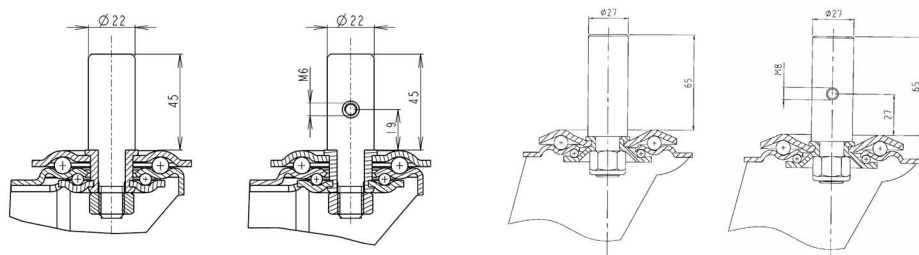

Otočná vidlica z oceleového plechu, pozinkovaná, s dvojitým guľíkovým vencom v smerevej otoči, os kolesa zaistená skrutkou

Gehäuse aus Stahlblech, verzinkt-chromatisiert, mit zweireihigem Kugelkranz im Gabelkopf















Housing made of pressed steel zinc-chromatised, double ball bearing swivel head

Upínanie na hladký čap Ø 22x45  
označenie: s priečnym otvorom 472.....H1  
označenie: bez priečneho otvoru 472

Upínanie na hladký čap Ø 27x65  
označenie: s priečnym otvorom 673.....H1  
označenie: bez priečneho otvoru 673













134

Otočné koleso Lenkrolle Swivel castor								
472 XB-V100č	100	38		22	45	39	125	90
472 XB-V125č	125	38		22	45	44	147	100
673 XB-V160č	160	45		27	65	49	193	205
673 XB-G160č	160	45		27	65	49	193	205
673 XB-V200č	200	50		27	65	55	232	205
673 XB-G200č	200	50		27	65	55	232	205















135

Otočné koleso s brzdou kolesa Rad-feststeller Wheel brake								
472B XB-V100č	100	38		22	45	39	125	90
472B XB-V125č	125	38		22	45	44	147	100















136

Otočné koleso s total brzdou Total-feststeller Total lock								
673F XB-V160č	160	45		27	65	49	193	205
673F XB-G160č	160	45		27	65	49	193	205
673F XB-V200č	200	50		27	65	55	232	205
673F XB-G200č	200	50		27	65	55	232	205



137

Otočné koleso s total brzdou Total-feststeller Total lock								
673T XB-V160č	160	45		27	65	49	193	205
673T XB-G160č	160	45		27	65	49	193	205
673T XB-V200č	200	50		27	65	55	232	205
673T XB-G200č	200	50		27	65	55	232	205

## Samostatné kolesá - séria XC

/nosnosť 100-300 kg/









138

Kolesá z oceleového plechu, zinkované, behúň kolesa - štandardná gumová obruč / , tvrdosť ShoreA 80 +/-5, /čiernej farby /č/, ložisko ihlové /V/

Stahlscheibenräder, mit Vollgummi-Rummireifen, Gummiqualitäten schwarz /č/, Ausführung: verzinkt-hromatiert, mit Rollenlager /V/,

Steel disc wheels with solid rubber tyre, black /č/ finish: zinc-chromatized, with roller bearing /V/,

Samostatné koleso Rad Wheel						 kg
XC-V080/12č	080	25	≡	12	37	100
XC-V100/15č	100	30	≡	12	37	130
XC-V125/15č	125	37	≡	15	47	160
XC-V160/20č	160	40	≡	20	57	250
XC-V200/20č	200	50	≡	20	57	300

### DOPLNKY



139

šedá gumová obruč

DOPLNKY	Dodatok ku obj. č.	Dodávané v Ø kolies
šedá gumová obruč	...Š	u všetkých priemerov

Kolesá s ihlovým ložiskom

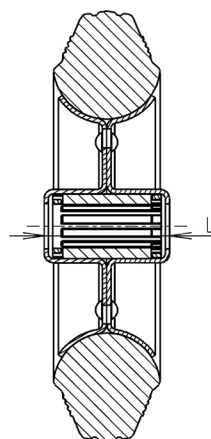

Označenie: XC-V....

## Transportné kolesá série 420,420F430,620,620F,630 s kolesami XC /nosnosť 100-300 kg/

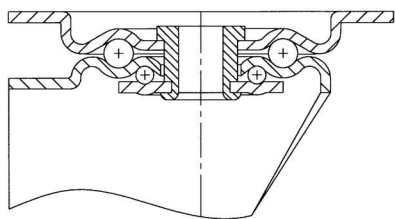

Otočná vidlica typ 420

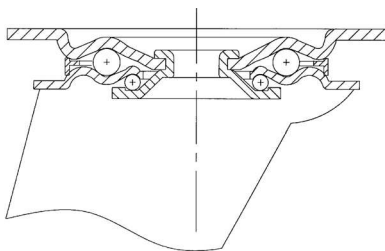

Otočná vidlica typ 620

Otočná vidlica z oceľového plechu, pozinkovaná, s dvojitým guľíkovým vencom v smerevej otoči, os kolesa zaistená skrutkou

Gehäuse aus Stahlblech, verzinkt-chromatisiert, mit zweireihigem Kugelkranz im Gabelkopf

Housing made of pressed steel zinc-chromatised, double ball bearing swivel head

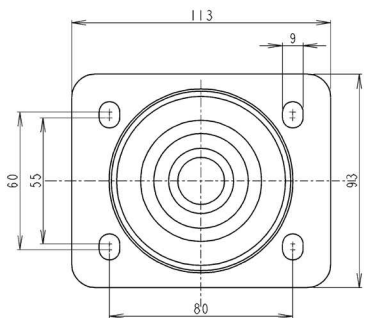

Upevňovacia príruha štvorhranná - typ P44  
na kolesá série 420,420B,430

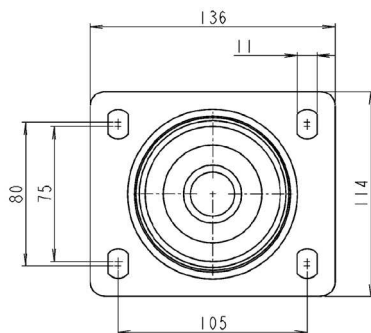

Upevňovacia príruha štvorhranná - typ P66  
na kolesá série 620,620F,630



140

Otočné koleso Lenkrolle Swivel castor									
420 XC-V080č	080	25	■	105x85	80x60	9	30	108	100
420 XC-V100č	100	30	■	105x85	80x60	9	35	128	130
420 XC-V125č	125	37	■	113x93	80x60	9	40	159	160
620 XC-V160č	160	40	■	136x114	105x80	11	47	195	250
620 XC-V200č	200	50	■	136x114	105x80	11	51	240	300



141

Pevné koleso Bockrolle Fixed castor									
430 XC-V080č	080	25	■	105x85	80x60	9	-	108	100
430 XC-V100č	100	30	■	105x85	80x60	9	-	128	130
430 XC-V125č	125	37	■	113x93	80x60	9	-	159	160
630 XC-V160č	160	40	■	136x114	105x80	11	-	195	250
630 XC-V200č	200	50	■	136x114	105x80	11	-	240	300



142

Otočné koleso s total brzdou Total-feststeller Total lock									
420F XC-V080č	080	25	■	105x85	80x60	9	30	108	100
420F XC-V100č	100	30	■	105x85	80x60	9	35	128	130
420F XC-V125č	125	37	■	113x93	80x60	9	40	159	160
620F XC-V160č	160	40	■	136x114	105x80	11	47	195	250
620F XC-V200č	200	50	■	136x114	105x80	11	51	240	300

## Samostatné kolesá - séria XE

/nosnosť 120-350 kg/













143

Disk kolesa z ocelového plechu, pozinkovaný, behúň - poloelastická kombinovaná gumová obruč Shore A 65+/-3, vnútorná päťka obruče z gummy tvrdej Shore A 90 /čiernej farby /č/, ložisko ihlové /V/, guľičkové /G/

Stahlscheiben Räder, mit Elastic Gummireifen, Gummiqualitäten schwarz /č/, mit Rollenlager /V/, Kugellager /G/

Steel disc wheels with elastic rubber tyre, black /č/ with roller bearing /V/, ball bearing /G/

Samostatné koleso Rad Wheel							
				L	L1		kg
XE-V125/15č	125	38		15	43	-	120
XE-G200/12č	200	50		12	61	-	350
XE-G200/17č	200	50		17	59	55	350

Kolesá s ihlovým ložiskom

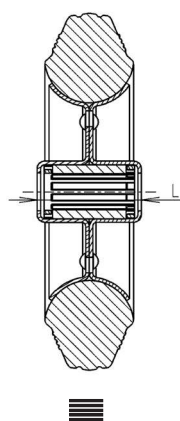

Označenie: XE-V...

Kolesá s guľičkovým ložiskom

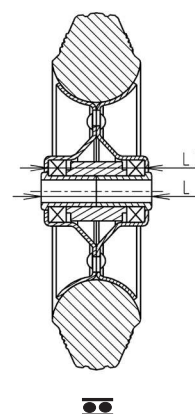

Označenie: XE-G...