

## Transportné kolesá série 673..HL,673T..HL,674..HL,674T..HL s kolesami ALE

/nosnosť 250-400 kg/

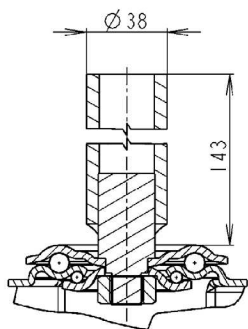

Upínanie na hladký čap Ø 38x143







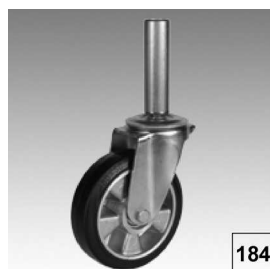





Otočná vidlica z oceleového plechu, pozinkovaná, s dvojitým guľíkovým vekom v smerovej otoči, os kolesa zaistená skrutkou

Gehäuse aus Stahlblech, verzinkt-chromatisiert, mit Kugelkranz im Gabelkopf

Housing made of pressed steel zinc-chromatised, ball bearing swivel head















184

Otočné koleso Lenkrolle Swivel castor								
673 ALE-G125č HL	125	50		38	143	53	165	250
673 ALE-G160č HL	160	50		38	143	49	199	300
674 ALE-G180č HL	180	50		38	143	55	230	350
674 ALE-G200č HL	200	50		38	143	55	238	400



185

Otočné koleso s total brzdou Total-feststeller Total lock								
673T ALE-G125č HL	125	50		38	143	53	165	250
673T ALE-G160č HL	160	50		38	143	49	199	300
674T ALE-G180č HL	180	50		38	143	55	230	350
674T ALE-G200č HL	200	50		38	143	55	238	400

## Samostatné kolesá - séria ATE

/nosnosť 600-800 kg/











186

Disk kolesa z hliníkovej liatiny, behúň - elastická gumová obruč / Shore A 65+/-3/, guľičkové ložisko/G/

Schwerlast-Räder, mit Elastik Vollgummibereifung, Radkörper aus Aluminium, mit Kugellager /G/

Heavy duty wheels with elastic rubber tyre, wheel centre of aluminium, with ball bearing /G/

Samostatné koleso Rad Wheel							
					L	L1	kg
ATE-G160/20č	160	50		20/25/	57	50	600
ATE-G200/20č	200	50		20/25/	57	50	800

### DOPLNKY



187

šedá gumová obruč

DOPLNKY	Dodatok ku obj. č.	Dodávané v Ø kolies
šedá gumová obruč	...š	u všetkých priemerov

Kolesá s guľičkovým ložiskom

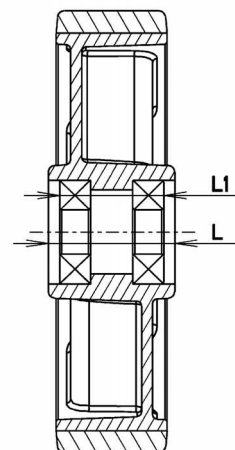

Označenie: ATE-G...

## Transportné kolesá série 824,824T,834,825,825T,835 s kolesami ATE /nosnosť 600-800 kg/

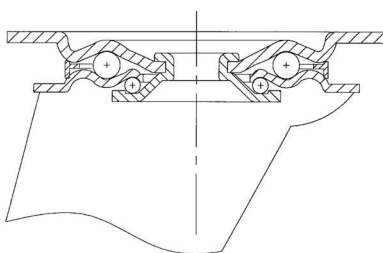
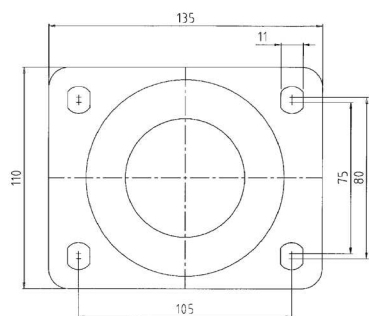

Otočná vidlica z oceleového plechu pozinkovaná, s guľičkovým ložiskom v smerovej otoči, os kolesa zaistená skrutkou

Gehäuse aus Stahlblech, verzinkt-chromatisiert, mit Kugelkranz im Gabelkopf













Housing made of pressed steel zinc-chromatised, double ball bearing swivel head

Upevňovacia príruha štvorhranná-typ P6  
na kolesá série 824,834,825,834

Otočná vidlica typ 824,825















188

Otočné koleso Lenkrolle Swivel castor									
824 ATE-G160č	160	50		135x110	105x80/75	11	49	200	600
824 ATE-G200č	200	50		135x110	105x80/75	11	61	245	600
825 ATE-G200č	200	50		135x110	105x80/75	11	61	245	800















189

Pevné koleso Bockrolle Fixed castor									
834 ATE-G160č	160	50		135x110	105x80/75	11	-	200	600
834 ATE-G200č	200	50		135x110	105x80/75	11	-	245	600
835 ATE-G200č	200	50		135x110	105x80/75	11	-	245	800



190

Otočné koleso s total brzdou Total-feststeller Total lock									
824T ATE-G160č	160	50		135x110	105x80/75	11	49	200	600
824T ATE-G200č	200	50		135x110	105x80/75	11	61	245	600
825T ATE-G200č	200	50		135x110	105x80/75	11	61	245	800

## Samostatné kolesá - séria LE

/nosnosť 400 kg/

**Použitie** - veľmi vhodné na transportné a manipulačné prepravné zariadenia, na ručné manipulačné vozíky











Disk kolesa zo šedej liatiny, behúň - elastická gumová obruč /tvrdosť Shore A 65+/-3/, čiernej farby /č/, ložisko guľičkové /G/

Schwerlast-Räder mit Elastik Vollgummibereifung, schwarz /č/, Radkörper aus Grauss, mit Kugellager /G/

Heavy duty wheels with elastic solid rubber tyre, wheel centre of grey cast iron, with ball bearing /G/

191

Samostatné koleso Rad Wheel						 kg
LE-G140/17č	140	40		17	48	400
LE-G150/17č	150	40		17	48	400
LE-G200/20	200	50		20	50	400

Kolesá s guľičkovým ložiskom

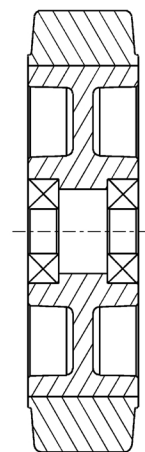

Označenie: LE-G...

## Transportné kolesá série 623,633,624,624T,634 s kolesami LE /nosnosť 300-400 kg/

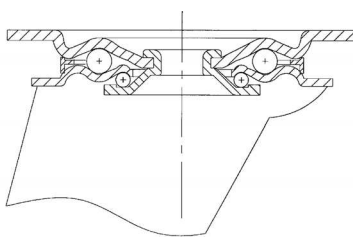
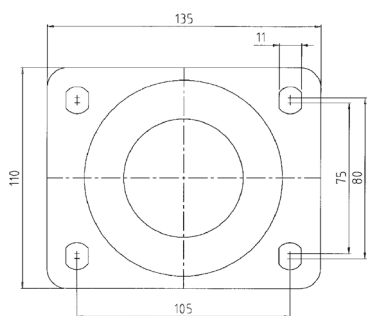

Otočná vidlica z oceľového plechu, pozinkovaná, s dvojitým guľíkovým vekom v smerovej otoči, os kolesa zaistená skrutkou

Gehäuse aus Stahlblech, verzinkt-chromatisiert, mit zweireihigem Kugellager im Gabelkopf













Housing made of pressed steel zinc-chromatised, ball bearing swivel head

Upevňovacia príruha štvorhranná-typ P6  
na kolesá série 623,633,624,634

Otočná vidlica typ 623,624







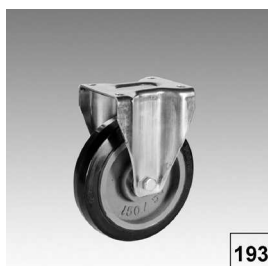







192

Otočné koleso Lenkrolle Swivel castor									
623 LE-G140č	140	40		135x110	105x80/75	11	53	175	300
624 LE-G150č	150	40		135x110	105x80/75	11	49	195	400
624 LE-G200č	200	50		135x110	105x80/75	11	55	240	400













193

Pevné koleso Bockrolle Fixed castor									
633 LE-G140č	140	40		135x110	105x80/75	11	-	175	300
634 LE-G150č	150	40		135x110	105x80/75	11	-	195	400
634 LE-G200č	200	50		135x110	105x80/75	11	-	240	400



194

Otočné koleso s total brzdou Total-feststeller Total lock									
624T LE-G150č	150	40		135x110	105x80/75	11	49	195	400
624T LE-G200č	200	50		135x110	105x80/75	11	55	240	400

## Transportné kolesá série 653 s kolesami LE /nosnosť 200 kg/

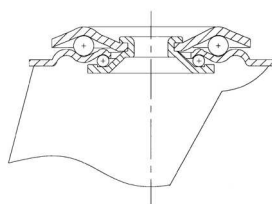
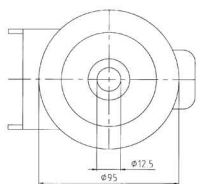

Upevnenie na stredový otvor  $\varnothing$  12,5  
na otočné vidlice série 653

Otočná vidlica typ 653









Otočná vidlica z oceleového plechu, pozinkovaná,  
s dvojitým guľičkovým vencom v smerovej otoči,  
os kolesa zaistená skrutkou

Gehäuse aus Stahlblech, verzinkt-  
chromatisiert, mit zweireihigem Kugelkranz im  
Gabelkopf

Housing made of pressed steel, zinc-  
chromatised, double ball bearing swivel head



195

Otočné koleso Lenkrolle Swivel castor							
653 LE-G140č	140	40		12,5	53	172	200

## Transportné kolesá série 673 s kolesami LE /nosnosť 300 kg/

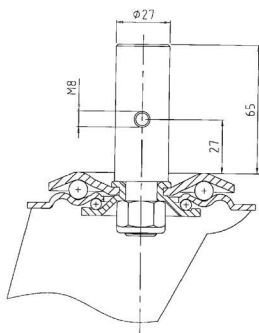
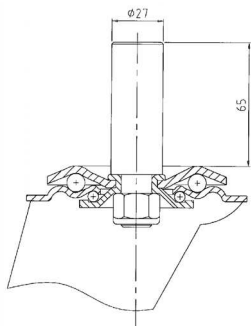

Upínanie na hladký čap  $\varnothing$  27x65  
označenie: bez priečného otvoru 673

označenie: s priečným otvorom 673.....H1

Otočná vidlica z oceleového plechu, pozinkovaná,  
s dvojitým guľičkovým vencom v smerovej otoči,  
os kolesa zaistená skrutkou

Gehäuse aus Stahlblech, verzinkt-chromatisiert,  
mit zweireihigem Kugelkranz im Gabelkopf

Housing made of pressed steel, zinc-chromati-  
sed, double ball bearing swivel head



196

Otočné koleso Lenkrolle Swivel castor								
673 LE-G140č	140	40		27	65	53	172	300

## Samostatné kolesá - séria CPB-č

/nosnosť 200 - 250 kg/











197

Kolesá z polyamidu, čiernej farby, guľičkové ložisko /G/

Radkörper aus Polyamid, schwarz, mit Kugellager /G/

Polyamide wheels, black, with ball bearing /G/

Samostatné koleso Rad Wheel						
CPB-g075/10č	075	35		10,2	45	200
CPB-G075/10č	075	35		10,2	45	250
CPB-g100/10č	100	35		10,2	45	200

Kolesá s guľičkovými ložiskami

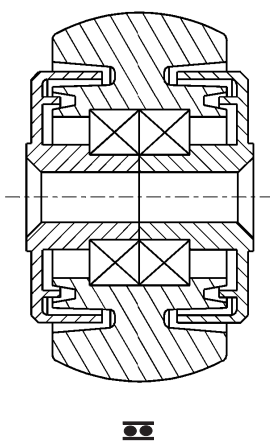

Označenie: CPB-G...

Kolesá s guľičkovým ložiskom

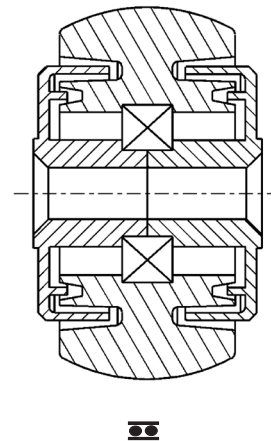

Označenie: CPB-g...

## Transportné kolesá série 423, 423B, 433 s kolesami CPB č /nosnosť 200 kg/

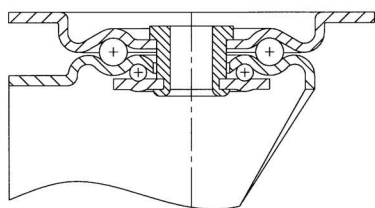
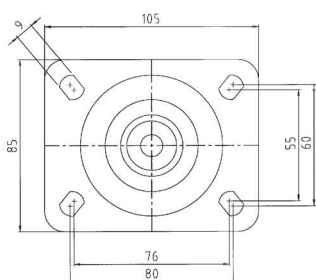

Otočná vidlica z oceľového plechu, pozinkovaná, s dvojitým guľíkovým vencom v smerovej otoči, os kolesa zaistená skrutkou

Gehäuse aus Stahlblech, verzinkt-chromatisiert, mit zweireihigem Kugelkranz im Gabelkopf











Housing made of pressed steel zinc-chromatised, double ball bearing swivel head

Upevňovacia príruha štvorhranná-typ P4  
na kolesá série 423

Otočná vidlica typ 423













198

Otočné koleso Lenkrolle Swivel castor									
423 CPB-g075č	075	35		105x85	80x60	9	38	100	200
423 CPB-g100č	100	35		105x85	80x60	9	39	130	200













199

Pevné koleso Bockrolle Fixed castor									
433 CPB-g075č*	075	35		105x85	80x60	9	-	100	200
433 CPB-g100č	100	35		105x85	80x60	9	-	130	200



200

Otočné koleso s brzdou kolesa Rad-feststeller Wheel brake									
423B CPB-g075č*	075	35		105x85	80x60	9	38	100	200
423B CPB-g100č	100	35		105x85	80x60	9	39	130	200

\*Zahájenie výroby na predaj: máj 2005



## Transportné kolesá série 453, 453B s kolesami CPB-č /nosnosť 200 kg/

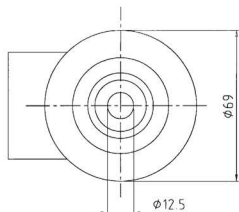

Upevnenie na stredový otvor  $\varnothing$  12,5  
na otočné vidlice série 453

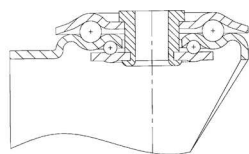

Otočná vidlica typ 453









Otočná vidlica z ocelového plechu, pozinkovaná, s dvojitým guľíkovým vencom v smerovej otoči, os kolesa zaistená skrutkou

Gehäuse aus Stahlblech, verzinkt-chromatisiert, mit zweireihigem Kugelkranz im Gabelkopf

Housing made of pressed steel, zinc-chromatised, double ball bearing swivel head











201

Otočné koleso Lenkrolle Swivel castor							
453 CPB-g075č	075	35		12,5	38	96	200
453 CPB-g100č	100	35		12,5	39	126	200



202

Otočné koleso s brzdou kolesa Rad-feststeller Wheel brake							
453B CPB-g075č*	075	35		12,5	38	96	200
453B CPB-g100č	100	35		12,5	39	126	200

## Transportné kolesá série 473, 473B s kolesami CPB-č /nosnosť 200 kg/

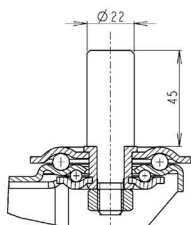

Upevnenie na hladký čap  $\varnothing$  22x45

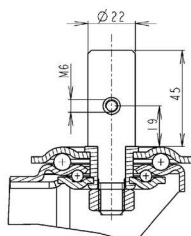

Upínanie na hladký čap  $\varnothing$  22x45  
s priečnym otvorom  
označenie: 473.....H1











Otočná vidlica z ocelového plechu, pozinkovaná, s dvojitým guľíkovým vencom v smerovej otoči, os kolesa zaistená skrutkou

Gehäuse aus Stahlblech, verzinkt-chromatisiert, mit zweireihigem Kugelkranz im Gabelkopf

Housing made of pressed steel, zinc-chromatised, double ball bearing swivel head













203

Otočné koleso Lenkrolle Swivel castor								
473 CPB-g075č	075	35		22	45	38	96	200
473 CPB-g100č	100	35		22	45	39	126	200



204

Otočné koleso s brzdou kolesa Rad-feststeller Wheel brake								
473B CPB-g075č*	075	35		22	45	38	96	200
475B CPB-g100č	100	35		22	45	39	126	200

\*Zahájenie výroby na predaj: máj 2005

## Samostatné kolesá - séria CPB

/nosnosť 150-200 kg/

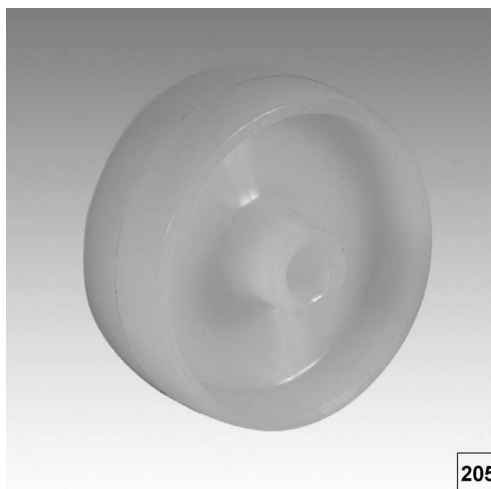







205

Kolesá z polyamidu, bielej farby, klzné uloženie /K/, ihlové ložisko /V/

Radkörper aus Polyamid, mit Gleitlager /K/, Rollenlager /V/

Polyamide wheels, with plain bearing /K/, roller bearing /V/

Samostatné koleso Rad Wheel						 kg
CPB-K080/12	080	35	≡	12,2	45	150
CPB-K100/12	100	35	≡	12,2	44	200
CPB-V100/15	100	35	≡≡	15	44	200
CPB-V125/15	125	38	≡≡	15	44	200

Kolesá s klzným  
uložením

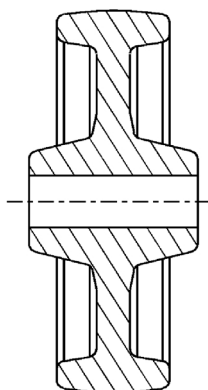

Označenie: CPB-K...

Kolesá s ihlovým  
ložiskom

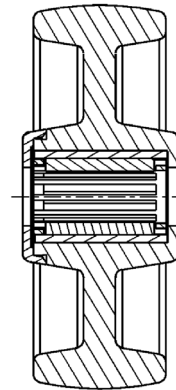

Označenie: CPB-V...

## Transportné kolesá série 422,422B,432,423,423B,433 s kolesami CPB /nosnosť 150-200 kg/

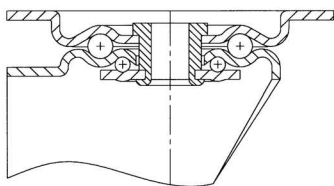
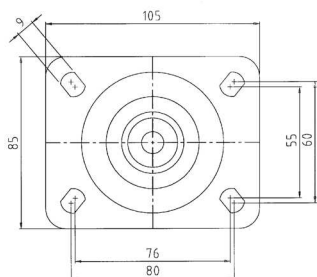

Otočná vidlica z ocelového plechu, pozinkovaná, s dvojitým guľíkovým vekom v smerovej otoči, os kolesa zaistená skrutkou

Gehäuse aus Stahlblech, verzinkt-chromatisiert, mit zweireihigem Kugelkranz im Gabelkopf









Housing made of pressed steel zinc-chromatised, double ball bearing swivel head

Upevňovacia príruha štvorhranná-typ P4  
na kolesá série 422,423,432,433

Otočná vidlica typ 422,423







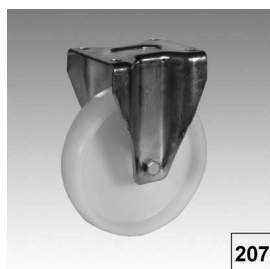



206

Otočné koleso Lenkrolle Swivel castor									
422 CPB-K080	080	35	=	105x85	80x60	9	38	103	150
422 CPB-K100	100	35	=	105x85	80x60	9	39	130	150
423 CPB-V100	100	35	≡	105x85	80x60	9	39	130	200
423 CPB-V125	125	38	≡	105x85	80x60	9	44	151	200



207

Pevné koleso Bockrolle Fixed castor									
432 CPB-K080*	080	35	=	105x85	80x60	9	-	103	150
432 CPB-K100	100	35	=	105x85	80x60	9	-	130	150
433 CPB-V100	100	35	≡	105x85	80x60	9	-	130	200
433 CPB-V125	125	38	≡	105x85	80x60	9	-	151	200



208

Otočné koleso s brzdou kolesa Rad-feststeller Wheel brake									
422B CPB-K080*	080	35	=	105x85	80x60	9	38	103	150
422B CPB-K100	100	35	=	105x85	80x60	9	39	130	150
423B CPB-V100	100	35	≡	105x85	80x60	9	39	130	200
423B CPB-V125	125	38	≡	105x85	80x60	9	44	151	200

\*Zahájenie výroby na predaj: máj 2005

## Transportné kolesá série 452,452B,453,453B s kolesami CPB

/nosnosť 150-200 kg/

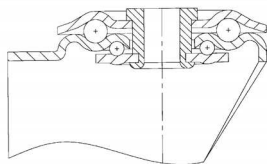
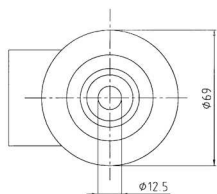

Otočná vidlica z ocelového plechu, pozinkovaná, s dvojitým guľíkovým vencom v smerovej otoči, os kolesa zaistená skrutkou

Gehäuse aus Stahlblech, verzinkt-chromatisiert, mit zweireihigem Kugelkranz im Gabelkopf







Housing made of pressed steel, zinc-chromatised, double ball bearing swivel head

Upevnenie na stredový otvor  $\varnothing$  12,5  
na otočné vidlice série 452,453

Otočná vidlica typ 452,453









209

Otočné koleso Lenkrolle Swivel castor							
452 CPB-K080	080	35	=	12,5	38	99	150
452 CPB-K100	100	35	=	12,5	39	126	150
453 CPB-V100	100	35	≡	12,5	39	126	200
453 CPB-V125	125	38	≡	12,5	44	151	200



210

Otočné koleso s brzdou kolesa Rad-feststeller Wheel brake							
452B CPB-K080*	080	35	=	12,5	38	99	150
452B CPB-K100	100	35	=	12,5	39	126	150
453B CPB-V100	100	35	≡	12,5	39	126	200
453B CPB-V125	125	38	≡	12,5	44	151	200

\*Zahájenie výroby na predaj: máj 2005

## Transportné kolesá série 472,472B,473,473B s kolesami CPB

/nosnosť 150-200 kg/

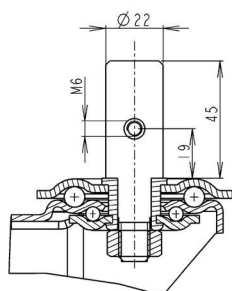
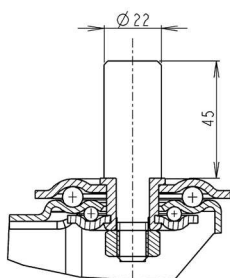

Otočná vidlica z oceleového plechu, pozinkovaná, s dvojitým guľičkovým vencom v smerovej otoči, os kolesa zaistená skrutkou









Gehäuse aus Stahlblech, verzinkt-chromatisiert, mit zweireihigem Kugelkranz im Gabelkopf

Housing made of pressed steel zinc-chromatised, double ball bearing swivel head









Upínanie na hladký čap Ø 22x45

Upínanie na hladký čap Ø 22x45  
s priečnym otvorom  
označenie: 472.....H1



Otočné koleso Lenkrolle Swivel castor								
472 CPB-K080	080	35	≡	22	45	38	99	150
472 CPB-K100	100	35	≡	22	45	39	126	150
473 CPB-V100	100	35	≡	22	45	39	126	200
473 CPB-V125	125	38	≡	22	45	44	151	200



Otočné koleso s brzdou klesa Rad-feststellerr Wheel brake								
472B CPB-K080*	080	35	≡	22	45	38	99	150
472B CPB-K100	100	35	≡	22	45	39	126	150
473B CPB-V100	100	35	≡	22	45	39	126	200
473B CPB-V125	125	38	≡	22	45	44	151	200

\*Zahájenie výroby na predaj: máj 2005

## Samostatné kolesá - séria CPC

/nosnosť 300-800 kg/

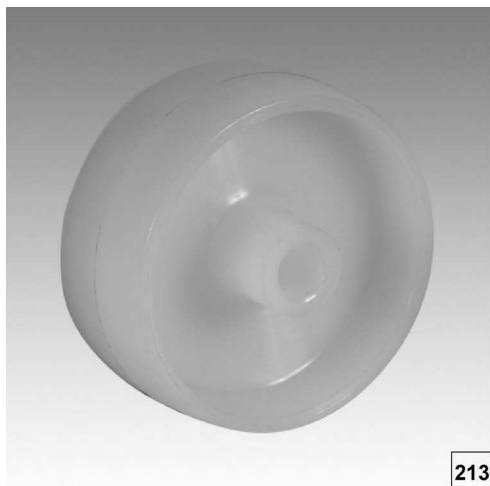

























213

Kolesá z polyamidu, klzné uloženie /K/, guľičkové ložisko /G/, ihlové ložisko /V/

Radkörper aus Polyamid, mit Gleitlager /K/, Rollenlager /V/, Kugellager /G/

Polyamide wheels with plain bearing /K/, roller bearing /V/, ball bearing /G/

Samostatné koleso Rad Wheel								
					L	L1	kg	
CPC-G125/20	125	45			20	52	50	300
CPC-K150/20	150	40			20	60	-	400
CPC-V150/20	150	50			20	60	-	600
CPC-G150/20	150	45			20	52	50	600
CPC-K160/20	160	40			20	58	-	500
CPC-V160/20	160	40			20	58	-	400
CPC-K200/20	200	50			20	60	-	800
CPC-V200/20	200	50			20	60	-	400
CPC-G200/20	200	50			20	60	40	800

Kolesá s klzným uložením

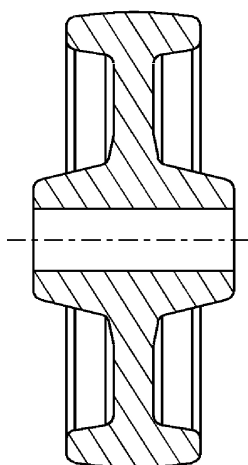

Označenie: CPC-K...

Kolesá s ihlovým ložiskom

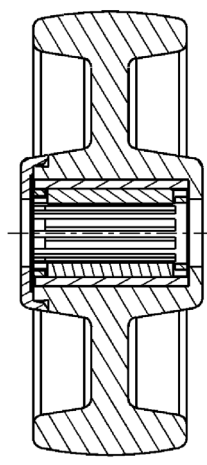

Označenie: CPC-V...

Kolesá s guľičkovým ložiskom

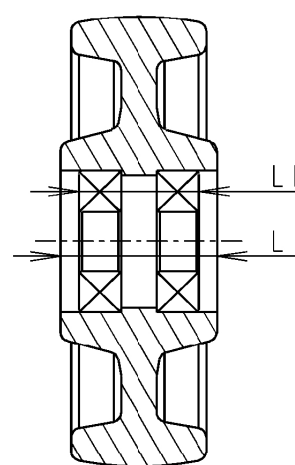

Označenie: CPC-G...

## Transportné kolesá série 623,623T,633,624,624T,634,824,824T,834,825,825T,835 s kolesami CPC /nosnosť 300-800 kg/

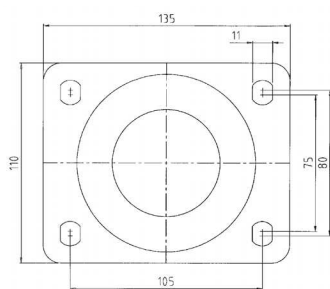

Upevňovacia príruha štvorhranná - typ P6  
na kolesá série 623,624,633,634

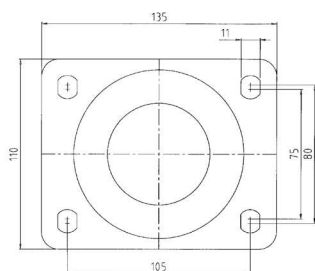

Upevňovacia príruha štvorhranná typ P6  
na kolesá série 824,834,825,834

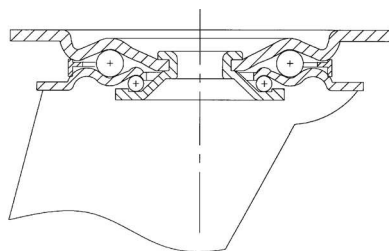

Otočná vidlica typ 623,624

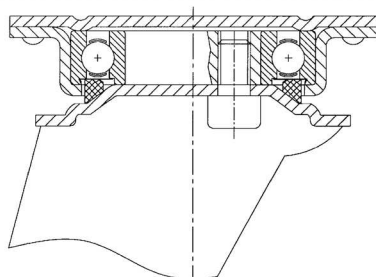

Otočná vidlica typ 824,825





















Otočná vidlica z oceleového plechu, pozinkovaná, s dvojitým guľičkovým vencom v smerovej otoči, os kolesa zaistená skrutkou

Gehäuse aus Stahlblech, verzinkt-chromatisiert, mit zweireihigem Kugelkranz im Gabelkopf

Housing made of pressed steel zinc-chromatised, double ball bearing swivel head



214

Otočné koleso Lenkrolle Swivel castor									
623 CPC-G125	125	45		135x110	105x80/75	11	53	164	300
624 CPC-K150	150	40		135x110	105x80/75	11	49	192	400
624 CPC-V150	150	40		135x110	105x80/75	11	49	192	400
624 CPC-G150	150	45		135x110	105x80/75	11	49	192	400
824 CPC-G150	150	45		135x110	105x80/75	11	52	197	600
624 CPC-K160	160	40		135x110	105x80/75	11	49	200	400
624 CPC-V160	160	40		135x110	105x80/75	11	49	200	400
624 CPC-K200	200	50		135x110	105x80/75	11	55	240	400
825 CPC-K200	200	50		135x110	105x80/75	11	61	245	800
624 CPC-V200	200	50		135x110	105x80/75	11	55	240	400
825 CPC-G200	200	50		135x110	105x80/75	11	61	245	800

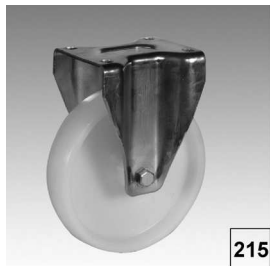

215

Pevné koleso Bockrolle Fixed castor									
633 CPC-G125	125	45		135x110	105x80/75	11	-	164	300
634 CPC-K150	150	40		135x110	105x80/75	11	-	192	400
634 CPC-V150	150	40		135x110	105x80/75	11	-	192	400
634 CPC-G150	150	45		135x110	105x80/75	11	-	192	400
834 CPC-G150	150	45		135x110	105x80/75	11	-	197	600
634 CPC-K160	160	40		135x110	105x80/75	11	-	200	400
634 CPC-V160	160	40		135x110	105x80/75	11	-	200	400
634 CPC-K200	200	50		135x110	105x80/75	11	-	240	400
835 CPC-K200	200	50		135x110	105x80/75	11	-	245	800
634 CPC-V200	200	50		135x110	105x80/75	11	-	240	400
835 CPC-G200	200	50		135x110	105x80/75	11	-	245	800
Otočné koleso s total brzdou Total-feststeller Total lock									
623T CPC-G125	125	45		135x110	105x80/75	11	53	164	300
624T CPC-K150	150	40		135x110	105x80/75	11	49	192	400
624T CPC-V150	150	40		135x110	105x80/75	11	49	192	400
624T CPC-G150	150	45		135x110	105x80/75	11	49	192	400
824T CPC-G150	150	45		135x110	105x80/75	11	52	197	600
624T CPC-K160	160	40		135x110	105x80/75	11	49	200	400
624T CPC-V160	160	40		135x110	105x80/75	11	49	200	400
624T CPC-K200	200	50		135x110	105x80/75	11	55	240	400
825T CPC-K200	200	50		135x110	105x80/75	11	61	245	800
624T CPC-V200	200	50		135x110	105x80/75	11	55	240	400
825T CPC-G200	200	50		135x110	105x80/75	11	61	245	800



216

**Transportné kolesá série 653,653T s kolesami CPC**  
/nosnosť 200 kg/

Otočná vidlica z ocelového plechu, pozinkovaná, s dvojitém guľčovým vencom v smerovej otoči, os kolesa zaistená skrutkou

Gehäuse aus Stahlblech, verzinkt-chromatisiert, mit zweireihigem Kugelkranz im Gabelkopf

Housing made of pressed steel, zinc-chromatised, double ball bearing swivel head

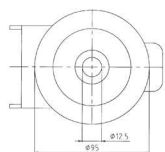

Upevnenie na stredový otvor Ø 12,5 na otočné vidlice série 653

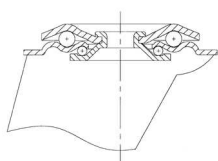

Otočná vidlica typ 653



217

Otočné koleso Lenkrolle Swivel castor							
653 CPC-G125	125	45		12,5	53	164	200



218

Otočné koleso s total brzdou Total-feststeller Total lock							
653T CPC-G125	125	45		12,5	53	164	200