

## Transportné kolesá série 673,673T,674,674T s kolesami CPC

/nosnosť 300 kg/

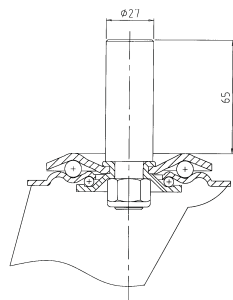

Upínanie na hladký čap Ø 27x65

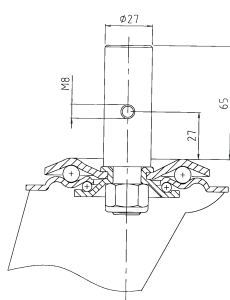

Upínanie na hladký čap Ø 27x65  
s pričným otvorom  
označenie: 673, 674.....H1







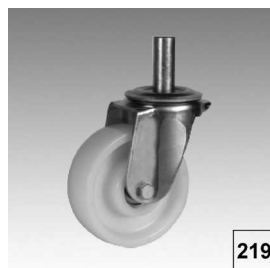









Otočná vidlica z oceľového plechu, pozinkovaná, s dvojitým guľíkovým vncom v smerovej otoči, os kolesa zaistená skrutkou

Gehäuse aus Stahlblech, verzinkt-chromatisiert, mit zweireihigem Kugelkranz im Gabelkopf

Housing made of pressed steel, zinc-chromatised, double ball bearing swivel head







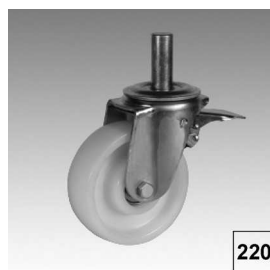











219

| Otočné koleso<br>Lenkrolle<br>Swivel castor |  |  |    |  |  |  |  |  |
|---|---|---|--|---|---|---|---|---|
| 673 CPC-G125                                | 125   | 45  |    | 27  | 65  | 53  | 164   | 300   |
| 674 CPC-K150                                | 150   | 40  |    | 27  | 65  | 49  | 186   | 300   |
| 674 CPC-V150                                | 150   | 40  |    | 27  | 65  | 49  | 186   | 300   |
| 674 CPC-G150                                | 150   | 45  |    | 27  | 65  | 49  | 186   | 300   |
| 674 CPC-K160                                | 160   | 40  |  | 27  | 65  | 49  | 191   | 300   |
| 674 CPC-V160                                | 160   | 40  |  | 27  | 65  | 49  | 191   | 300   |
| 674 CPC-K200                                | 200   | 50  |  | 27  | 65  | 55  | 232   | 300   |
| 674 CPC-V200                                | 200   | 50  |  | 27  | 65  | 55  | 232   | 300   |
| 674 CPC-G200                                | 200   | 50  |  | 27  | 65  | 55  | 232   | 300   |



220

| Otočné koleso<br>s total brzdou<br>Total-feststeller<br>Total lock |  |  |  |  |  |  |  |  |
|--|---|---|--|---|---|---|---|---|
| 673T CPC-G125  | 125   | 45  |  | 27  | 65  | 53  | 164   | 300   |
| 674T CPC-K150  | 150   | 40  |  | 27  | 65  | 49  | 186   | 300   |
| 674T CPC-V150  | 150   | 40  |  | 27  | 65  | 49  | 186   | 300   |
| 674T CPC-G150  | 150   | 45  |  | 27  | 65  | 49  | 186   | 300   |
| 674T CPC-K160  | 160   | 40  |  | 27  | 65  | 49  | 191   | 300   |
| 674T CPC-V160  | 160   | 40  |  | 27  | 65  | 49  | 191   | 300   |
| 674T CPC-K200  | 200   | 50  |  | 27  | 65  | 55  | 232   | 300   |
| 674T CPC-V200  | 200   | 50  |  | 27  | 65  | 55  | 232   | 300   |
| 674T CPC-G200  | 200   | 50  |  | 27  | 65  | 55  | 232   | 300   |

## Transportné kolesá série 674, 674T s kolesami CPC /nosnosť 400 kg/

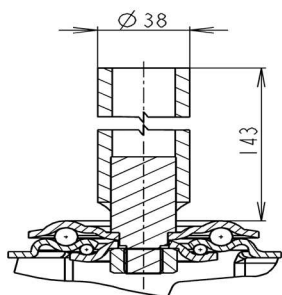

Otočná vidlica z oceľového plechu, pozinkovaná, s dvojitým guľíkovým vekom v smerovej otoči, os kolesa zaistená skrutkou















Gehäuse aus Stahlblech, verzinkt-chromatisiert, mit zweireihigem Kugelkranz im Gabelkopf

Housing made of pressed steel, zinc-chromatised, double ball bearing swivel head

Upínanie na hladký čap Ø 38x143

















221

| Otočné koleso<br>Lenkrolle<br>Swivel castor |  |  |    |  |  |  |  |  |
|---|---|---|---|---|---|---|---|---|
| 674 CPC-G150 HL                             | 150   | 45  |    | 38  | 143   | 49  | 186   | 400   |
| 674 CPC-K160 HL                             | 160   | 40  |    | 38  | 143   | 49  | 191   | 400   |
| 674 CPC-V160 HL                             | 160   | 40  |    | 38  | 143   | 49  | 191   | 400   |
| 674 CPC-K200 HL                             | 200   | 50  |    | 38  | 143   | 55  | 232   | 400   |
| 674 CPC-V200 HL                             | 200   | 50  |  | 38  | 143   | 55  | 232   | 400   |
| 674 CPC-G200 HL                             | 200   | 50  |  | 38  | 143   | 55  | 232   | 400   |



222

| Otočné koleso<br>s total brzdou<br>Total-feststeller<br>Total lock |  |  |  |  |  |  |  |  |
|--|---|---|---|---|---|---|---|---|
| 674T CPC-G150 HL   | 150   | 45  |  | 38  | 143   | 49  | 186   | 400   |
| 674T CPC-K160 HL   | 160   | 40  |  | 38  | 143   | 49  | 191   | 400   |
| 674T CPC-V160 HL   | 160   | 40  |  | 38  | 143   | 49  | 191   | 400   |
| 674T CPC-K200 HL   | 200   | 50  |  | 38  | 143   | 55  | 232   | 400   |
| 674T CPC-V200 HL   | 200   | 50  |  | 38  | 143   | 55  | 232   | 400   |
| 674T CPC-G200 HL   | 200   | 50  |  | 38  | 143   | 55  | 232   | 400   |

## KOLESÁ S VIDLICAMI Z NEREZOVÉHO PLECHU

Použitie: do potravinárskeho priemyslu

### Samostatné kolesá - séria CPB, CPC

/nosnosť 150-800 kg/

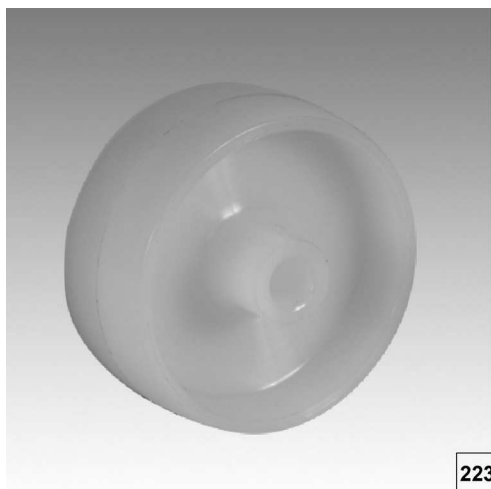







223

Kolesá z polyamidu, bielej farby, klzné uloženie /K/

Radkörper aus Polyamid mit Gleitlager /K/

Polyamide wheels with plain bearing /K/

| Samostatné koleso<br>Rad<br>Wheel |  |  |  |  |  | <br>kg |
|-----------------------------------|---|---|---|---|---|---|
| CPB-K080/12                       | 080   | 35  | =   | 12,2  | 45  | 150   |
| CPB-K100/12                       | 100   | 35  | =   | 12,2  | 44  | 200   |
| CPC-K160/20                       | 160   | 40  | =   | 20  | 58  | 500   |
| CPC-K200/20                       | 200   | 50  | =   | 20  | 60  | 800   |

Kolesá s klzným  
uložením

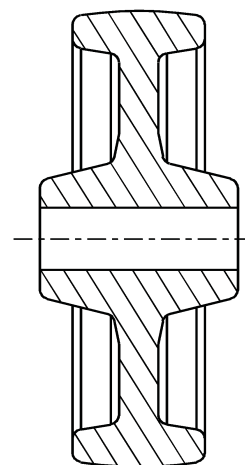

=

Označenie: CPC-K...

## Transportné kolesá série 42X,43X,62X,63X s kolesami CPB, CPC

/nosnosť 150-300 kg/

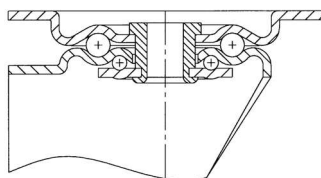
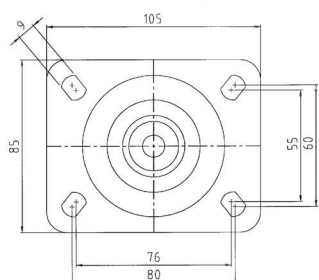

Otočná vidlica z nerezového plechu, s dvojitým nerezovým guľičkovým vencom v smerovej otoči, os kolesa zaistená nerezovou skrutkou

Gehäuse aus Edelstahl, mit zweireihigem Edelstahlkugelkranz im Gabelkopf

Housing made of pressed Stainlesssteel, double ball bearing swivel head

Upevňovacia príruha štvorhranná-typ P4 na kolesá série 42X, 43X

Otočná vidlica nerezová 42X

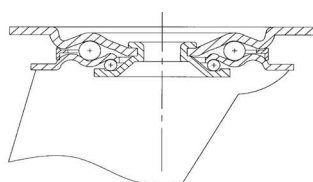
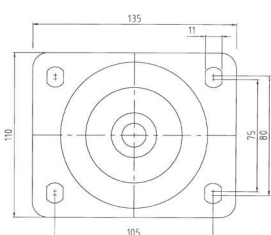

Upevňovacia príruha štvorhranná-typ P6 na kolesá série 62X, 63X

Otočná vidlica nerezová 62X



224



225



226

| Otočné koleso<br>Lenkrolle<br>Swivel castor                        |     |    |   |         |        |    |    |     |     |  |
|--|-----|----|---|---------|--------|----|----|-----|-----|--|
| 42X CPB-K080   | 080 | 35 | = | 105x85  | 80x60  | 9  | 38 | 103 | 150 |  |
| 42X CPB-K100   | 100 | 35 | = | 105x85  | 80x60  | 9  | 38 | 130 | 200 |  |
| 62X CPB-K160   | 160 | 40 | = | 135x110 | 105x80 | 11 | 49 | 200 | 300 |  |
| 62X CPC-K200   | 200 | 50 | = | 135x110 | 105x80 | 11 | 55 | 233 | 300 |  |
| Pevné koleso<br>Bockrolle<br>Fixed castor                          |     |    |   |         |        |    |    |     |     |  |
| 43X CPB-K080   | 080 | 35 | = | 105x85  | 80x60  | 9  | -  | 103 | 150 |  |
| 43X CPB-K100   | 100 | 35 | = | 105x85  | 80x60  | 9  | -  | 130 | 200 |  |
| 62X CPC-K160   | 160 | 40 | = | 135x110 | 105x80 | 11 | -  | 200 | 300 |  |
| 63X CPC-K200   | 200 | 50 | = | 135x110 | 105x80 | 11 | -  | 233 | 300 |  |
| Otočné koleso<br>s total brzdou<br>Total-feststeller<br>Total lock |     |    |   |         |        |    |    |     |     |  |
| 42XF CPB-K100  | 100 | 35 | = | 105x85  | 80x60  | 9  | 38 | 130 | 200 |  |
| 62XF CPC-K160  | 160 | 40 | = | 135x110 | 105x80 | 11 | 49 | 200 | 300 |  |
| 62XF CPC-K200  | 200 | 50 | = | 135x110 | 105x80 | 11 | 55 | 233 | 300 |  |

## Samostatné kolesá - séria CNB, CNC

/nosnosť 100 - 205 kg/









227

Kolesá z polypropylénu, pri teplote pod -10 °C a nad +25 °C výrazné zníženie nosnosti o 50%, klzné uloženie /K/

Radkörper aus Polypropylene mit Gleitlager /K/

Polypropylene wheel with plain bearing /K/

| Samostatné koleso<br>Rad<br>Wheel |  |  |  |  |  | <br>kg |
|-----------------------------------|---|---|---|---|---|---|
| CNB-K100/12                       | 100   | 35  | ≡   | 12  | 44  | 100   |
| CNC-K150/20                       | 150   | 40  | ≡   | 20  | 60  | 200   |
| CNC-K200/20                       | 200   | 50  | ≡   | 20  | 60  | 205   |

Kolesá s klzným  
uložením

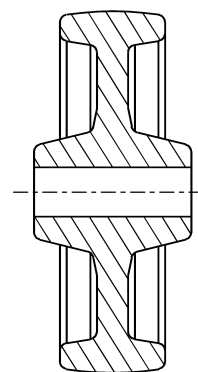

≡

Označenie: CNB, CNC-K...

## Transportné kolesá série 422, 422B, 432, 623, 623T, 633 s kolesami CNB, CNC /nosnosť 100-205 kg/

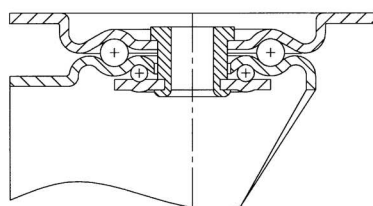
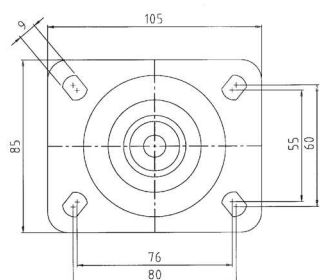

Otočná vidlica z oceleového plechu, pozinkovaná, s dvojitým guľičkovým vencom v smerovej otoči, os kolesa zaistená skrutkou

Gehäuse aus Stahlblech, verzinkt-chromatisiert, mit zweireihigem Kugelkranz im Gabelkopf

Housing made of pressed steel zinc-chromatised, double ball bearing swivel head

Upevňovacia príruha štvorhranná-typ P4  
na kolesá série 422, 432

Otočná vidlica typ 422

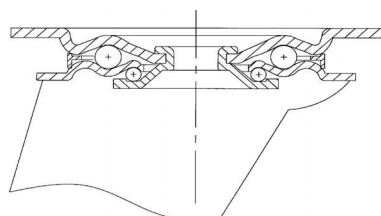
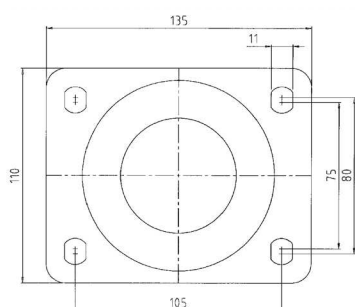









Upevňovacia príruha štvorhranná-typ P6  
na kolesá série 623, 633

Otočná vidlica typ 623











228

| Otočné koleso<br>Lenkrolle<br>Swivel castor |  |  |  |  |  |  |  |  |  |
|---|---|---|---|---|---|---|---|---|---|
| 422 CNB-K100                                | 100   | 38  | =   | 105x85  | 80x60   | 9   | 39  | 130   | 100   |
| 623 CNC-K150                                | 150   | 40  | =   | 135x110   | 105x80/75   | 11  | 49  | 194   | 200   |
| 623 CNC-K200                                | 200   | 50  | =   | 135x110   | 105x80/75   | 11  | 55  | 240   | 205   |



229

| Pevné koleso<br>Bockrolle<br>Fixed castor |  |  |  |  |  |  |  |  |  |
|---|---|---|---|---|---|---|---|---|---|
| 432 CNB-K100                              | 100   | 38  | =   | 105x85  | 80x60   | 9   | -   | 130   | 100   |
| 633 CNC-K150                              | 150   | 40  | =   | 135x110   | 105x80/75   | 11  | -   | 194   | 200   |
| 633 CNC-K200                              | 200   | 50  | =   | 135x110   | 105x80/75   | 11  | -   | 240   | 205   |

**230**

Otočné koleso  
s brzdou kolesa  
Rad-feststeller  
Wheel brake



|               |     |    |   |        |       |   |    |     |     |
|---------------|-----|----|---|--------|-------|---|----|-----|-----|
| 422B CNB-K100 | 100 | 38 | = | 105x85 | 80x60 | 9 | 39 | 130 | 100 |
|---------------|-----|----|---|--------|-------|---|----|-----|-----|

**231**

Otočné koleso  
s total brzdou  
Total-feststeller  
Total lock



|               |     |    |   |         |           |    |    |     |     |
|---------------|-----|----|---|---------|-----------|----|----|-----|-----|
| 623T CNC-K150 | 150 | 40 | = | 135X110 | 105X80/75 | 11 | 49 | 194 | 200 |
|---------------|-----|----|---|---------|-----------|----|----|-----|-----|

|               |     |    |   |         |           |    |    |     |     |
|---------------|-----|----|---|---------|-----------|----|----|-----|-----|
| 623T CNC-K200 | 200 | 50 | = | 135X110 | 105X80/75 | 11 | 55 | 240 | 205 |
|---------------|-----|----|---|---------|-----------|----|----|-----|-----|

## Transportné kolesá série 452,452B,653,653T s kolesami CNB, CNC

/nosnosť 100-205 kg/

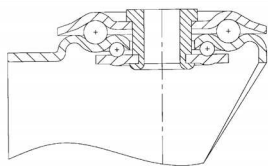
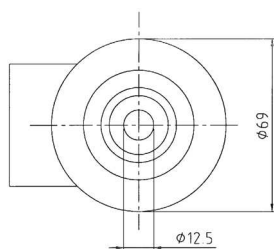

Otočná vidlica z oceľového plechu, pozinkovaná, s dvojitým guľíkovým vekom v smerovej otoči, os kolesa zaistená skrutkou

Gehäuse aus Stahlblech, verzinkt-chromatisiert, mit zweireihigem Kugelkranz im Gabelkopf

Housing made of pressed steel zinc-chromatised, double ball bearing swivel head

Upevnenie na stredový otvor  $\varnothing$  12,5 na otočné vidlice série 452

Otočná vidlica typ 452

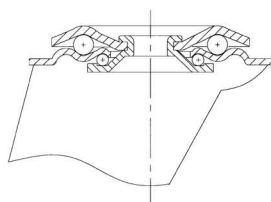
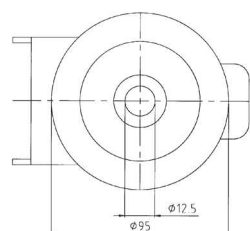







Upevnenie na stredový otvor  $\varnothing$  12,5 na otočné vidlice série 653

Otočná vidlica typ 653









232

| Otočné koleso<br>Lenkrolle<br>Swivel castor |  |  |  |  |  |  |     |
|---|---|---|---|---|---|---|-----|
| 452 CNB-K100                                | 100   | 38  | ≡   | 12,5  | 39  | 126   | 100 |
| 653 CNC-K150                                | 150   | 40  | ≡   | 12,5  | 49  | 186   | 200 |
| 653 CNC-K200                                | 200   | 50  | ≡   | 12,5  | 55  | 232   | 205 |









233

| Otočné koleso<br>s brzdou kolesa<br>Rad-feststeller<br>Wheel brake |  |  |  |  |  |  |     |
|--|---|---|---|---|---|---|-----|
| 452B CNB-K100  | 100   | 38  | ≡   | 12,5  | 39  | 126   | 100 |



234

| Otočné koleso<br>s total brzdou<br>Total-feststeller<br>Total lock |  |  |  |  |  |  |     |
|--|---|---|---|---|---|---|-----|
| 653T CNC-K150  | 150   | 40  | ≡   | 12,5  | 49  | 186   | 200 |
| 653T CNC-K200  | 200   | 50  | ≡   | 12,5  | 55  | 232   | 205 |



## Transportné kolesá série 472,472B,673,673T s kolesami CNB,CNC

/nosnosť 100-205 kg/

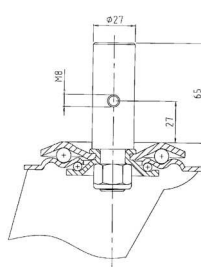
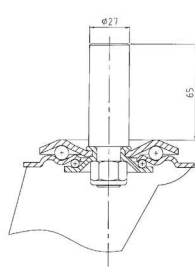
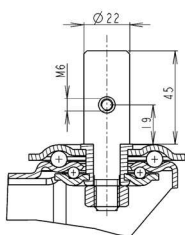
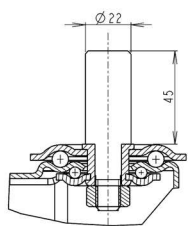

Otočná vidlica z oceleového plechu, pozinkovaná, s dvojitým guľíkovým vencom v smerovej otoči, os kolesa zaistená skrutkou

Gehäuse aus Stahlblech, verzinkt-chromatisiert, mit zweireihigem Kugelkranz im Gabelkopf

Housing made of pressed steel, zinc-chromatised, double ball bearing vencom in swivel head









Upínanie na hladký čap Ø 22x45  
označenie - 472

Upínanie na hladký čap Ø 27x65  
označenie- 673









Upínanie na hladký čap Ø 22x45  
s pričným otvorom  
označenie - 472 .....H1

Upínanie na hladký čap Ø 27x65  
s pričným otvorom  
označenie - 673.....H1











| Otočné koleso<br>Lenkrolle<br>Swivel castor |  |  |  |  |  |  |  |  |
|---|---|---|---|---|---|---|---|---|
| 472 CNB-K100                                | 100   | 38  | ≡   | 22  | 45  | 39  | 126   | 100   |
| 673 CNC-K150                                | 150   | 40  | ≡   | 27  | 65  | 49  | 186   | 200   |
| 673 CNC-K200                                | 200   | 50  | ≡   | 27  | 65  | 55  | 232   | 205   |



| Otočné koleso s brzdou kolesa<br>Rad-feststeller<br>Wheel brake |  |  |  |  |  |  |  |  |
|---|---|---|---|---|---|---|---|---|
| 472B CNB-K100   | 100   | 38  | ≡   | 22  | 45  | 39  | 126   | 100   |



| Otočné koleso s total brzdou<br>Rad-feststeller<br>Total lock |  |  |  |  |  |  |  |  |
|---|---|---|---|---|---|---|---|---|
| 673T CNC-K150   | 150   | 40  | ≡   | 27  | 65  | 49  | 186   | 200   |
| 673T CNC-K200   | 200   | 50  | ≡   | 27  | 65  | 55  | 232   | 205   |

## Samostatné kolesá - séria PUB

/nosnosť 150-175 kg/

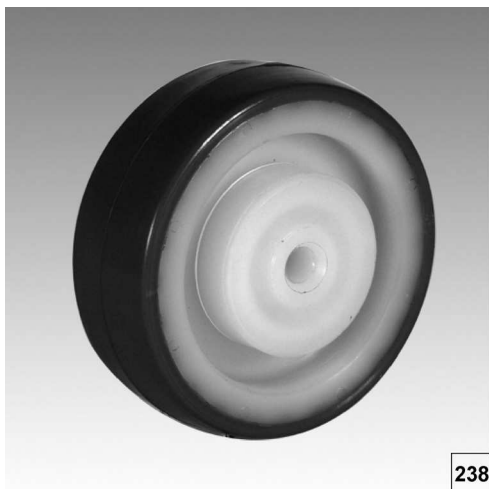









238

Disk kolesa z polyamidu, s polyuretánovou obručou /Shore A98/, ložisko guľičkové /G/, ihľové /V/

Polyamid Räder, mit Polyurethan - Lauffläche, Kugellager /G/, Rollenlager /V/

Polyamide wheel with polyurethan tread, ball bearings /G/, roller bearing /V/

| Samostatné koleso<br>Rad<br>Wheel |  |  |   |  |  |  |
|-----------------------------------|--|--|---|--|--|--|
| PUB-V080-35/12*                   | 080  | 35   |  | 12   | 45   | 150  |
| PUB-G100-35/10                    | 100  | 35   |  | 10,2   | 45   | 175  |

\*Zahájenie výroby a predaja: máj 2005

Kolesá s ihľovým ložiskom

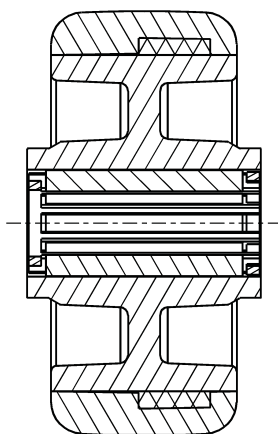

Označenie: PUB-V...

Kolesá s guľičkovým ložiskom

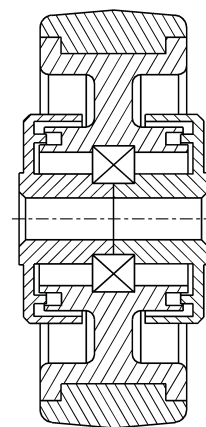

Označenie: PUB-G...

## Transportné kolesá série 422,422B,432,423, 423B, 433 s kolesami PUB

/nosnosť 150-175 kg/

### Upevňovacie príruby štvorhranné

Otočná vidlica z oceleového plechu, pozinkovaná, s dvojitým guľíkovým vencom v smerovej otoči, os kolesa zaistená skrutkou

Gehäuse aus Stahlblech, verzinkt-chromatisiert, mit zweireihigem Kugelkranz im Gabelkopf

Housing made of pressed steel zinc-chromatised, double ball bearing swivel head

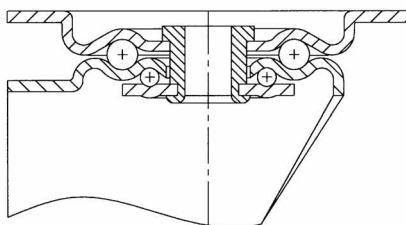
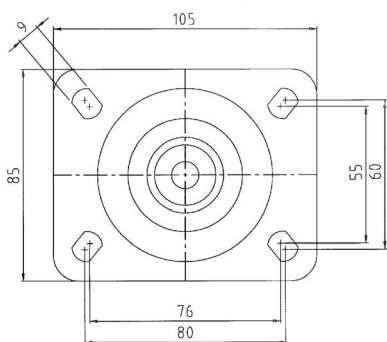









Upevňovacia príruha štvorhraná - typ P4  
na kolesá série 422, 423

Otočná vidlica typ 422, 423







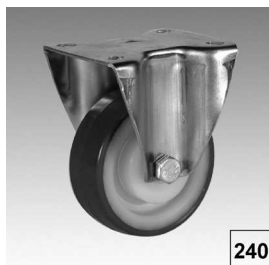





239

| Otočné koleso<br>Lenkrolle<br>Swivel castor |  |  |     |  |  |  |  |  |  |
|---|---|---|--|--|---|---|---|---|---|
| 422 PUB-V080*                               | 080   | 35  |   | 105x85   | 80x60   | 9   | 39  | 108   | 150   |
| 423 PUB-G100                                | 100   | 35  |  | 105x85   | 80x60   | 9   | 39  | 130   | 175   |













240

| Pevné koleso<br>Bockrolle<br>Fixed castor |  |  |   |  |  |  |  |  |  |
|---|---|---|--|--|---|---|---|---|---|
| 432 PUB-V080*                             | 080   | 35  |  | 105x85   | 80x60   | 9   | -   | 108   | 150   |
| 433 PUB-G100                              | 100   | 35  |  | 105x85   | 80x60   | 9   | -   | 130   | 175   |



241

| Otočné koleso<br>s brzdou kolesa<br>Rad-feststeller<br>Wheel brake |  |  |   |  |  |  |  |  |  |
|--|---|---|--|--|---|---|---|---|---|
| 422B PUB-V080*   | 080   | 35  |  | 105x85   | 80x60   | 9   | 39  | 108   | 150   |
| 423B PUB-G100  | 100   | 35  |  | 105x85   | 80x60   | 9   | 39  | 130   | 175   |

\*Zahájenie výroby a predaja: máj 2005

## Samostatné kolesá - séria PUC

/nosnosť 500-600 kg/











242

Disk kolesa z polyamidu, s polyuretánovou obručou /Shore A98/, ložisko guľičkové /G/

Polymaid Räder, mit Polyurethan - Lauffläche, Kugellager /G/,

Polyamide wheel with polyurethan tread, ball bearings /G/

| Samostatné koleso<br>Rad<br>Wheel |  |  |   |  |  |  |  |
|-----------------------------------|--|--|---|--|--|--|--|
|                                   |  |  |   |  | L  | L1   | kg   |
| PUC-G175/20                       | 175  | 45   |  | 20   | 48   | 42   | 500  |
| PUC-G200/20                       | 200  | 50   |  | 20   | 55   | 40   | 600  |

Kolesá s guľičkovým ložiskom

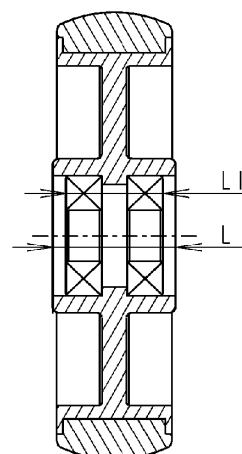

Označenie: PUC-G...

## Transportné kolesá série 624,624T,634,824,824T,834 s kolesami PUC /nosnosť 400-600 kg/

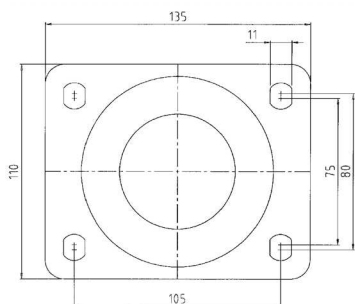

Upevňovacia príruha štvorhranná - typ P6  
na kolesá série 624,634

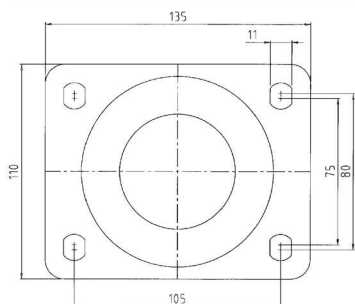

Upevňovacia príruha štvorhranná - typ P6  
na kolesá série 824,834

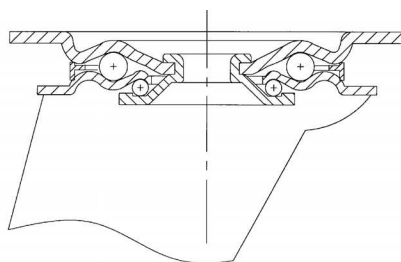

Otočná vidlica typ 624

Otočná vidlica z oceleového plechu, pozinkovaná, s dvojitým guľičkovým vencom v smerovej otoči, os kolesa zaistená skrutkou

Gehäuse aus Stahlblech, verzinkt-chromatisiert, mit zweireihigem Kugellager im Gabelkopf



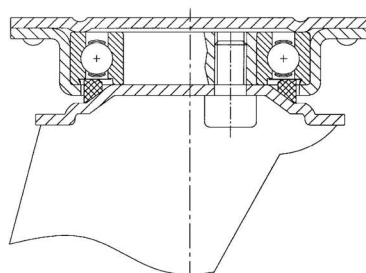





Housing made of pressed steel zinc-chromatised, double ball bearing swivel head



Otočná vidlica typ 824















243

| Otočné koleso<br>Lenkrolle<br>Swivel castor |  |  |  |  |  |  |  |  |  | kg |
|---|---|---|---|---|---|---|---|---|---|----|
| 624 PUC-G175                                | 175   | 45  |  | 135x110   | 105x80/75   | 11  | 55  | 227   | 400   |    |
| 824 PUC-G175                                | 175   | 45  |  | 135x110   | 105x80/75   | 11  | 61  | 232   | 500   |    |
| 824 PUC-G200                                | 200   | 50  |  | 135x110   | 105x80/75   | 11  | 61  | 245   | 600   |    |















244

| Pevné koleso<br>Bockrolle<br>Fixed castor |  |  |  |  |  |  |  |  |  | kg |
|---|---|---|---|---|---|---|---|---|---|----|
| 634 PUC-G175                              | 175   | 45  |  | 135x110   | 105x80/75   | 11  | -   | 227   | 400   |    |
| 834 PUC-G175                              | 175   | 45  |  | 135x110   | 105x80/75   | 11  | -   | 232   | 500   |    |
| 834 PUC-G200                              | 200   | 50  |  | 135x110   | 105x80/75   | 11  | -   | 245   | 600   |    |



245

| Otočné koleso<br>s total brzdou<br>Total-feststeller<br>Total lock |  |  |  |  |  |  |  |  |  | kg |
|--|---|---|---|---|---|---|---|---|---|----|
| 624T PUC-G175  | 175   | 45  |  | 135x110   | 105x80/75   | 11  | 55  | 227   | 400   |    |
| 824T PUC-G175  | 175   | 45  |  | 135x110   | 105x80/75   | 11  | 61  | 232   | 500   |    |
| 824T PUC-G200  | 200   | 50  |  | 135x110   | 105x80/75   | 11  | 61  | 245   | 600   |    |

## TEPLOTNE ODOLNÉ KOLESÁ

### Samostatné kolesá - séria CFZ

Použitie - veľmi vhodné do prostredia s teplotou od -50°C do +280°C

/nosnosť 100 - 125 kg/









246

Kolesá zo špeciálnej zmesi teplotne odolné /od -50°C do +280°C / klzné uloženie /K/

Räder mit hitzebeständigem Fett, bei Dauerbeanspruchung ca./-50°C +280°C/,mit Gleitlager /K/

Solid Phenolic resin wheels, resistant to high temperature for permanent stressing approx./-50°C +280°C/,with plain bearing /K/

| Samostatné koleso<br>Rad<br>Wheel |  |  |  |  |  | <br>kg |
|-----------------------------------|---|---|---|---|---|---|
| CFZ-K080/12                       | 080   | 35  | =   | 12  | 39  | 100   |
| CFZ-K100/12                       | 100   | 35  | =   | 12  | 42  | 125   |

Kolesá s klzným uložením

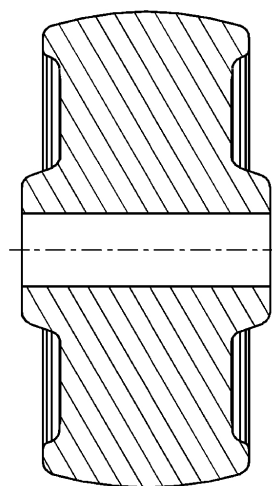

=

Označenie: CFZ-K...

## Transportné kolesá série 423,433,42X,43X s kolesami CFZ

/nosnosť 100-125 kg/

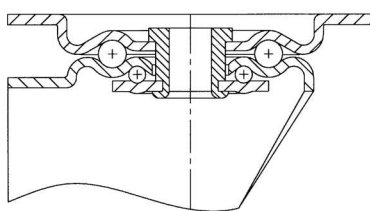
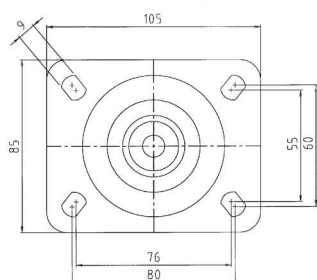

Otočná vidlica z oceleového plechu pozinkovaná /423/ alebo z nerezového plechu /42X/, s dvojitým guľíkovým vencom v smerovej otoči, os kolesa zaistená skrutkou

Gehäuse aus Stahlblech, verzinkt-chromatisiert /423/, oder aus Edelstahl /42X/ mit zweireihigem Kugelkranz im Gabelkopf

Housing made of pressed steel, zinc-chromatised /423/, or Stainless /42X/ double ball bearing swivel head

Upevňovacia príruha štvorhranná-typ P4 na kolesá série 423,433,42X,43X

Otočná vidlica typ 423,42X



247

| Otočné koleso<br>Lenkrolle<br>Swivel castor |     |    |   |        |       |   |    |     |     |
|---|-----|----|---|--------|-------|---|----|-----|-----|
| 423 CFZ-K 080                               | 080 | 35 | = | 105x80 | 80x60 | 9 | 38 | 110 | 100 |
| 423 CFZ-K 100                               | 100 | 35 | = | 105x85 | 80x60 | 9 | 38 | 129 | 125 |



248

| Otočné koleso<br>Lenkrolle<br>Swivel castor |     |    |   |        |       |   |    |     |     |
|---|-----|----|---|--------|-------|---|----|-----|-----|
| 42X CFZ-K 080                               | 080 | 35 | = | 105x85 | 80x60 | 9 | 38 | 111 | 100 |
| 42X CFZ-K 100                               | 100 | 35 | = | 105x85 | 80x60 | 9 | 38 | 130 | 120 |



249

| Pevné koleso<br>Bockrolle<br>Fixed castor |     |    |   |        |       |   |   |     |     |
|---|-----|----|---|--------|-------|---|---|-----|-----|
| 433 CFZ-K 080                             | 080 | 35 | = | 105x80 | 80x60 | 9 | - | 110 | 100 |
| 433 CFZ-K 100                             | 100 | 35 | = | 105x85 | 80x60 | 9 | - | 129 | 125 |



250

| Pevné koleso<br>Bockrolle<br>Fixed castor |     |    |   |        |       |   |   |     |     |
|---|-----|----|---|--------|-------|---|---|-----|-----|
| 43X CFZ-K 080                             | 080 | 35 | = | 105x85 | 80x60 | 9 | - | 111 | 100 |
| 43X CFZ-K 100                             | 100 | 35 | = | 105x85 | 80x60 | 9 | - | 130 | 120 |

## Transportné kolesá série 453 s kolesami CFZ

/nosnosť 100-125 kg/

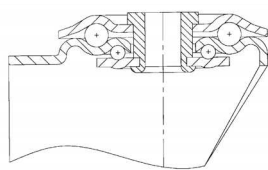
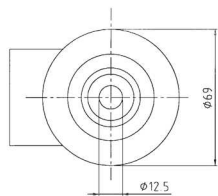

Upevnenie na stredový otvor  $\varnothing$  12,5  
na otočné vidlice série 453

Otočná vidlica typ 453

Otočná vidlica z ocelového plechu, pozinkovaná, s dvojitým guľíkovým vencom v smerovej otoči, os kolesa zaistená skrutkou

Gehäuse aus Stahlblech, verzinkt-chromatisiert, mit zweireihigem Kugelkranz im Gabelkopf

Housing made of pressed steel zinc-chromatised, double ball bearing swivel head



251

| Otočné koleso<br>Lenkrolle<br>Swivel castor |     |    |   |      |    |     |     |
|---|-----|----|---|------|----|-----|-----|
| 453 CFZ-K080                                | 080 | 35 | = | 12,5 | 38 | 110 | 100 |
| 453 CFZ-K100                                | 100 | 35 | = | 12,5 | 38 | 129 | 125 |

## Transportné kolesá série 473 s kolesami CFZ

/nosnosť 100-125 kg/

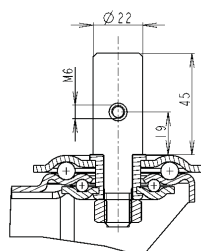
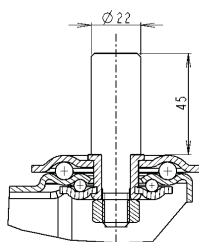

Upevnenie na hladký čap  $\varnothing$  22x45

Upevnenie na hladký čap  $\varnothing$  22x45  
s priečnym otvorom  
označenie: 473.....H1

Otočná vidlica z ocelového plechu, pozinkovaná, s dvojitým guľíkovým vencom v smerovej otoči, os kolesa zaistená skrutkou

Gehäuse aus Stahlblech, verzinkt-chromatisiert, mit zweireihigem Kugelkranz im Gabelkopf

Housing made of pressed steel zinc-chromatised, double ball bearing swivel head



252

| Otočné koleso<br>Lenkrolle<br>Swivel castor |     |    |   |    |    |    |     |
|---|-----|----|---|----|----|----|-----|
| 473 CFZ-K080                                | 080 | 35 | = | 22 | 45 | 38 | 100 |
| 473 CFZ-K100                                | 100 | 35 | = | 22 | 45 | 38 | 129 |