







**324**

### CPB

Kolesá z polyamidu, klzné uloženie /K/, ihlové ložisko/V/

Radkörper aus Polyamid mit Gleitlager /K/, Rollenlager/V/

Polyamide wheels with plain bearing /K/ roller bearing/V/

Samostatné koleso Rad Wheel							
					L	L1	kg
CPB-K080/12	080	35	≡	12,2	45	45	150
CPB-K100/12	100	35	≡	12,2	44	44	200
CPB-V100/15	100	35	≡	15	44	44	200
CPB-V125/15	125	38	≡	15	44	44	200

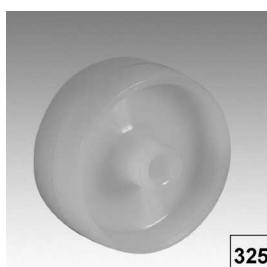
**325**

### CPC

Kolesá z polyamidu, klzné uloženie /K/, guľičkové ložisko /G/, ihlové ložisko /V/

Radkörper aus Polyamid mit Gleitlager /K/, Rollenlager/V/, Kugellager /G/

Polyamide wheels with plain bearing /K/, roller bearing/V/, ball bearing /G/

CPC-G125/20	125	45	≡	20	52	50	300
CPC-K150/20	150	40	≡	20	60	-	400
CPC-V150/20	150	50	≡	20	60	-	600
CPC-G150/20	150	45	≡	20	52	50	600
CPC-K160/20	160	40	≡	20	58	-	500
CPC-V160/20	160	40	≡	20	58	-	400
CPC-K200/20	200	50	≡	20	60	-	800
CPC-V200/20	200	50	≡	20	60	-	400
CPC-G200/20	200	50	≡	20	60	40	800

**326**

### CNB, CNC

Kolesá z polypropylénu, pri teplote nad +25 °C výrazné zníženie nosnosti o 50%, klzné ložisko /K/

Radkörper aus Polypropylene mit Gleitlager /K/

Polypropylene wheel with plain bearing /K/

CNB-K100/12	100	35	≡	12	44	-	100
CNC-K150/20	150	40	≡	20	60	-	200
CNC-K200/20	200	50	≡	20	60	-	205

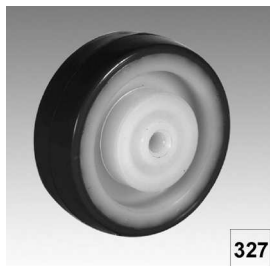









### PUB

Disk koleša z polyamidu, s polyuretánovou obručou /Shore A 98/, ložisko guľičkové/G/, ihlové /V/

Polyamid Räder, mit Polyurethan Lauffläche, Kugellager /G/, Rollenlager/V/,

Polyamide wheel with polyurethan tread, ball bearings /G/, roller bearing/V/

Samostatné koleso Rad Wheel							
PUB-V080-35/12*	080	35		12	45	-	150
PUB-G100-35/10	100	35		10,2	45	-	175

\* Zahájenie výroby a predaja: máj 2005





### PUC

Disk koleša z polyamidu, s polyuretánovou obručou /Shore A 98/, ložisko guľičkové/G/

Polyamid Räder, mit Polyurethan Lauffläche, Kugellager /G/

Polyamide wheel with polyurethan tread, ball bearings /G/

PUC-G175/20	175	45		20	48	42	500
PUC-G200/20	200	50		20	55	40	600





### CFZ-teplotne odolné

Kolesá zo špeciálnej zmesi teplotne odolné /od - 50°C do + 280°C/ klzné uloženie /K/

Räder mit hitzebeständigem Fett, bei Dauerbeanspruchung ca./-50°C +280°C/, mit Gleitlager /K/

Solid Phenolic resin wheels, resistant to high temperature for permanent stressing approx./-50°C +280°C/,with plain bearing /K/

CFZ-K 080/12	080	35		12	39	-	100
CFZ-K 100/12	100	35		12	42	-	125

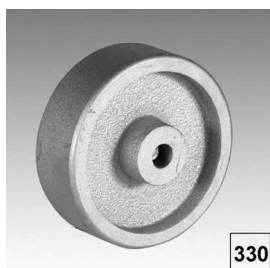



### CL - teplotne odolné

Kolesá zo šedej liatiny, klzné uloženie /K/,teplotne odolné /od -50°C do +280°C/

Räder aus Grauguss mit Gleitlager /K/, Dauerbeanspruchung ca./-50°C +280°C/

Wheels of grey cast iron /CL/, with plain bearing/K/, resistant to high temperature for permanent stressing approx./-50°C +280°C

CL-K070/12	070	25		12,1	32	-	55
CL-K100/12	100	33		12,1	44	-	100













**331**

### XJ č - zinkované

Disk kolesa z ocelového plechu, pozinkovaný, behúň - nafukovacia duša a plášť čiernej farby /č/, ložisko ihlové /V/, guľičkové /G/

Stahlscheibenräder mit Luftbereifung Ausführung: verzinkt-chromatiert, mit Rollenlager /V/, Kugellager /G/

Pneumatic tyred wheels with steel center, with roller bearing /V/, ball bearing /G/

Samostatné koleso Rad Wheel			Rozmer pneumat	Tlak vzduchu /bar/						
XJ-V260/20č	260	85	3,00-4	2,5		20	75	-	-	200
XJ-G260/20č	260	85	3,00-4	2,5		20	55	50	-	200
XJ-G260/20č L2	260	85	3,00-4	2,5		20	55	50	5	200
XJ-G300/20č	300	100	3,00-4	2,5		20	50	-	-	220













**332**

### XJ š - zinkované

Disk kolesa z ocelového plechu, pozinkovaný, behúň - nafukovacia duša a plášť šedej farby /š/, ložisko ihlové /V/, guľičkové /G/

Stahlscheibenräder mit Luftbereifung Ausführung: verzinkt-chromatiert, mit Rollenlager /V/, Kugellager /G/

Pneumatic tyred wheels with steel center, with roller bearing /V/, ball bearing /G/

Samostatné koleso Rad Wheel			Rozmer pneumat	Tlak vzduchu /bar/						
XJ-V260/20š	260	85	3,00-4	2,5		20	75	-	-	200
XJ-G260/20š	260	85	3,00-4	2,5		20	55	50	-	200
XJ-G260/20š L2	260	85	3,00-4	2,5		20	55	50	5	200

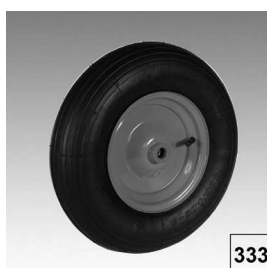











**333**

### XJ - farbené

Disk kolesa z ocelového plechu, komaxit, behúň - nafukovacia duša a plášť čiernej farby /č/, ložisko ihlové /V/, guľičkové /G/, klzné uloženie /K/

Stahlscheibenräder mit Luftbereifung Ausführung: komaxit, mit Rollenlager /V/, Kugellager /G/, Gleitlager /K/

Pneumatic tyred wheels with steel center, with roller bearing /V/, ball bearing /G/, plain bearing /K/

Samostatné koleso Rad Wheel			Rozmer pneumat	Tlak vzduchu /bar/						
XJ-K400/20 č	400	100	4,00-8	1,7		20	100	-	-	150
XJ-V400/20 č	400	100	4,00-8	1,7		20	100	-	-	150
XJ-G400/20 č	400	100	4,00-8	1,7		20	60	52	-	150











**334**

### AJ

Disk z hliník.zliatiny, behúň - nafukovacia duša a plášť čiernej farby /č/,guličkové /G/,

Radkörper aus Aluminium mit Luftbereifung, mit Kugellager /G/

Pneumatic tyred wheels with aluminium center, with ball bearing /G/,

Samostatné koleso Rad Wheel			Rozmer pneumat	Tlak vzduchu /bar/						
AJ-G420/25č	420	110	16x4	2,0		25	90	70	-	200











**335**

### XL - zinkované

Disk kolesa z ocelového plechu, pozinkovaný, behúň štandardná celogumová obruč /tvrdosť Shore A80 +/- 5/, čiernej farby/č/, ložisko ihlové /V/, guličkové /G/

Stahlscheibenräder mit Vollgummi-Reifen, Gummiqualitäten schwarz /č/ Ausführung: verzinkt-chromatiert, mit Rollenlager/V/, Kugellager /G/

Steel disc wheels with solid rubber tyre black /č/, finish: zinc-chromatized, with roller bearing /V/, ball bearing /G/

Samostatné koleso Rad Wheel								
XL-V256/20č	256	76		20	75	-	300	
XL-G256/20č	256	76		20	50	-	300	

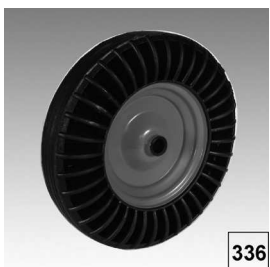













**336**

### XL - farbené

Disk kolesa z ocelového plechu, farbený, behúň - štandardná celogumová obruč /tvrdosť Shore A 80 +/- 5/, čiernej farby/č/, ložisko ihlové /V/, klzné uloženie /K/

Stahlscheibenräder mit Vollgummi-Reifen, Gummiqualitäten schwarz /č/, mit Rollenlager/V/, Rollenlager /V/

Steel disc wheels with solid rubber tyre black /č/, with roller bearing /V/, roller bearing /V/

Samostatné koleso Rad Wheel							
XL-K320/30	320	80	Bez ložiska-rura	30	60	-	250
XL-K360/25	360	75		25	100	-	150
XL-K370/30	370	80	Bez ložiska-rura	30	60	-	250
XL-K400/12	400	100		12	100	-	150
XL-K400/20	400	100		20	100	-	150
XL-K400/25	400	100		25	100	-	150
XL-V400/25	400	100		25	100	-	150
XL-G400/25	400	100		25	100	-	150







**337**

### NJ - č

Kolesá s nafukovacou dušou a plášťom čiernej farby /č/, disk z polypropylénu, ihlové ložisko /V/ kľzné uloženie /K/

Polypropylen Räder mit Luftbereifung, Rollenlager /V/, Gleitlager /K/

Polypropylene wheel whit pneumatic tyred, with roller, plain bearing /K/

Samostatné koleso Rad Wheel			Rozmer pneumat	Tlak vzduchu /bar/				
NJ-K260/20 č	260	85	3,00-4	2,5	==	20	75	130
NJ-V260/20 č	260	85	3,00-4	2,5	===	20	75	130
NJ-K235/20 č	350	98	-	2,5	==	20	91	130







**338**

### NJ - š

Kolesá s nafukovacou dušou a plášťom šedej farby /NJ/, disk z polypropylénu, guľičkové ložisko /g/, ihlové ložisko /V/, kľzné uloženie /K/

Polypropylen Räder mit Luftbereifung, Kugellager /g/, Rollenlager /V/, Gleitlager /K/

Polypropylene wheel with pneumatic tyred /NJ/, with ball bearing /g/, with roller, plain bearing /K/

Samostatné koleso Rad Wheel			Rozmer pneumat	Tlak vzduchu /bar/				
NJ-g200/8š	200	50	2,50-4	2,5	==	8,5	60	75
NJ-K260/20š	260	85	3,00-4	2,5	==	20	75	130
NJ-V260/20š	260	85	3,00-4	2,5	===	20	75	130







**339**

### NU

Kolesá s polyuretánovou obušou /NU/, disk z polypropylénu, guľičkové ložisko /g/

Polypropylen Räder mit Polyurethan-Lauffläche, Kugellager /g/

Polypropylene wheel whit polyurethane tread /NU/, with ball bearing /g/

Samostatné koleso Rad Wheel						
NU-g200/8	200	50	==	8,5	60	75

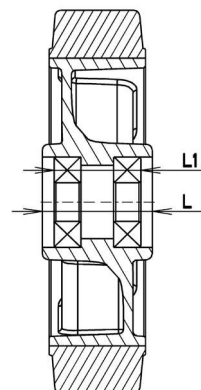
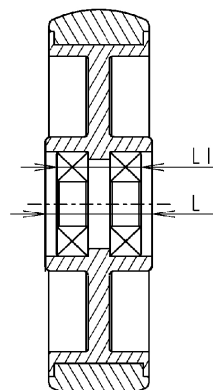
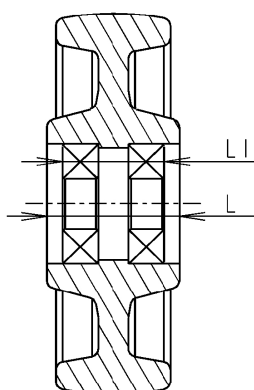

## SAMOSTATNÉ ŤAŽKÉ TRANSPORTNÉ KOLESÁ

/nosnosť 350-2000 kg/

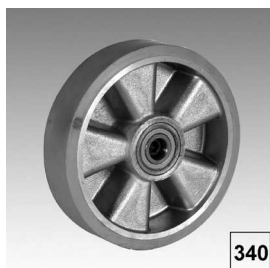











340

### ALU

Disk kolesa z hliníkovej liatiny, behúň - polyuretánová obruč /Shore 92 +/- 3/, ložisko guľičkové /G/

Aluminium Räder, mit Polyurethan - lauffläche, mit Kugellager /G/

Light aluminium centre wheels, with polyurethan tread, with ball bearing/G/

Samostatné koleso Rad Wheel							
ALU-G125/20	125	50		20	57	50	350
ALU-G160/20	160	50		20	57	50	600
ALU-G200/20	200	50		20 /25/	57	50	800

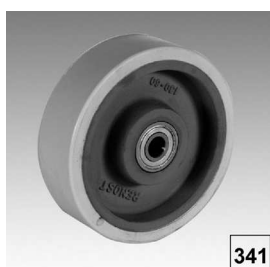



341

### LU

Disk kolesa zo šedej liatiny, behúň polyuretánová obruč /Shore 92 +/- 3/, ložisko guľičkové /G/

Gussräder, mit Polyurethan - lauffläche, mit Kugellager /G/

Cast iron centre wheels, with polyurethan tread, with ball bearing/G/

LU-G180/20	180	50		20	50	-	1000
LU-G200/20	200	60		20	60	-	1200
LU-G250/25	250	80		25	80	-	1500



342

### CL - teplotne odolné

Kolesá zo šedej liatiny, guľičkové /G/, teplotne odolné /od -50°C do +280°C/

Räder aus Grauguss mit Kugellager/G/, Dauerbeanspruchung ca./-50°C +280°C/

Wheels of grey cast iron, with ball bearing /G/, resistant to high temperature for permanent stressing approx./-50°C +280°C/

CL-G150/20 Z	150	50		20	50	-	800
CL-G150/20 Z /SO/ - teplotne odolné	150	50		20	50	-	800
CL-G180/20	180	60		20	60	-	1000
CL-G225/25	225	80		25	80	-	2000

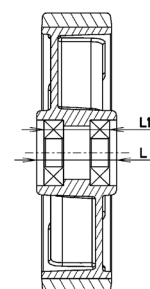

## Kolesá na nízkozdvižné a vysoko zdvižné vozíky

/nosnosť 350-1000 kg/











### PREDNÉ KOLESÁ



343

#### CPC

Kolesá z polyamidu, guľičkové ložisko /G/  
Radkörper aus Polyamid mit, Kugellager /G/  
Polyamide wheels with ball bearing /G/

Samostatné koleso Rad Wheel								
	L	L1	L2	kg				
CPC-G175/20 L2	175	50		20	55	42	5	500
CPB-G200/20	200	50		20	55	40	-	600

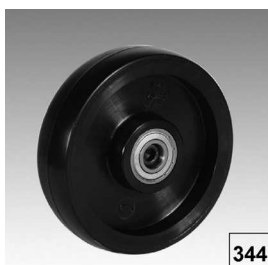



344

#### PUC

Disk kolesa z polyamidu čiernej farby, s polyuretánovou obručou /Shore A98/, ložisko guľičkové/G/

Polyamid Räder, mit Polyurethan - Lauffläche, Kugellager /G/

Polyamide wheel with polyurethan tread, ball bearings /G/

PUC-G175/20č L2	175	45		20	48	42	5	500
PUC-G200/20č	200	50		20	55	40	-	600



345

#### ALE

Disk kolesa z hliníkovej liatiny, behúň - elastická gumová obruč /Shore A65 +/- 3/ čiernej farby /č/, guľičkové ložisko /G/,

Schwerlast-Räder mit Elastik Vollgummibereifung, Radkörper aus Aluminium, Gummiqualitäten schwarz /č/, mit Kugellager /G/

Heavy duty wheels with elastic rubber tyre, wheel centre of aluminium, with ball bearing /G/

ALE-G180/20č	180	50		20/25/	57	42/50/	5	350
ALE-G200/20č	200	50		20/25/	57	50	-	400



346

#### ALT

Disk kolesa z hliníkovej liatiny, behúň štandardná gumová obruč /Shore A80 +/- 5/, guľičkové ložisko /G/

Schwerlast-Räder mit Vollgummibereifung, Radkörper aus Aluminium, Gummiqualitäten schwarz/č/, mit Kugellager /G/

Heavy duty wheels with elastic rubber tyre, wheel centre of aluminium, with ball bearing /G/

ALT-G180/20č L2	180	50		20	57	42/50/	5	350
ALT-G200/20č	200	50		20	57	40	-	400











**347**

### ALU

Disk kolesa z hliníkovej liatiny, behúň - polyuretánová obruč /Shore 92 +/- 3/, ložisko guľičkové /G/

Aluminium Räder, mit Polyurethan - lauffläche, mit Kugellager /G/

Light aluminium centre wheels, with polyurethan tread, with ball bearing/G/

Samostatné koleso Rad Wheel								
ALU-G200/20	200	50		20/25/	57	50	-	800

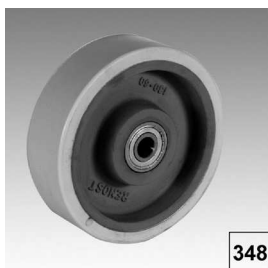









**348**

### LU

Disk kolesa zo šedej liatiny, behúň - polyuretánová obruč /Shore 92 +/- 3/, ložisko guľičkové /G/

Graugussräder, mit Polyurethan - lauffläche, mit Kugellager /G/

Cast iron centre wheels, with polyurethan tread, ball bearing/G/

Samostatné koleso Rad Wheel								
LU-G180/20č	180	50		20	50	50	-	1000



## ZADNÉ KOLESÁ - SINGEL/TANDEM

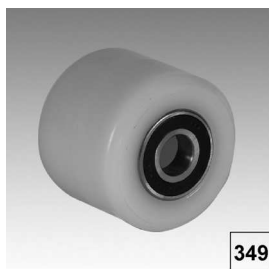









**349**

### CPZ

Kolesá z polyamidu, guľičkové ložisko /G/

Radkörper aus Polyamid mit, Kugellager /G/

Polyamide wheels with ball bearing /G/

Samostatné koleso Rad Wheel								
					L	L1	L2	kg
CPZ-G082-70/20-tandem	082	70		20	70	-	-	510
CPZ-G082-90/20-singel	082	90		20	90	-	-	510













**350**

### PUZ

Disk kolesa z polyamidu, s polyuretánovou obručou /Shore A 98/, ložisko guľičkové/G/

Polyamid Räder, mit Polyurethan - Lauffläche, Kugellager /G/

Polyamide wheel with polyurethan tread, ball bearings /G/

Samostatné koleso Rad Wheel								
					L	L1	L2	kg
PUZ-G082-60/20-tandem	082	60		20	60	-	-	510
PUZ-G082-70/20-tandem	082	70		20	70	-	-	510
PUZ-G082-90/20-singel	082	90		20	90	-	-	510

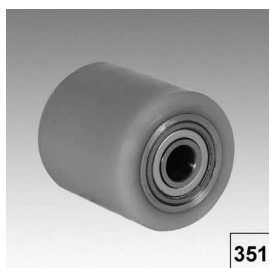









**351**

### LUZ

Disk kolesa zo šedej liatiny, behúň - polyuretánová obruč /Shore 92 +/- 3/, ložisko guľičkové /G/

Graugussräder, mit Polyurethan - lauffläche, mit Kugellager /G/

Cast iron centre wheels, with polyurethan tread, ball bearing/G/

Samostatné koleso Rad Wheel								
					L	L1	L2	kg
LUZ-G082-70/20-tandem	082	70		20	70	-	-	510
LUZ-G082-90/20-singel	082	90		20	90	-	-	510

**352**
**CAZ**

Kolesá z hliníkovej liatiny, ložisko guľičkové /G/

Aluminium Räder, mit Kugellager /G/

Aluminium centre wheels, ball bearing/G/

 Samostatné koleso  
 Rad  
 Wheel

CAZ-G082-70/25-tandem

082

70



20,25

70

-

-



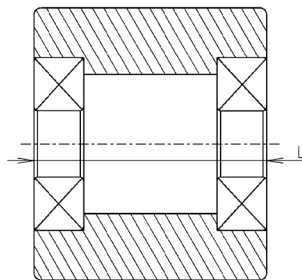



2000

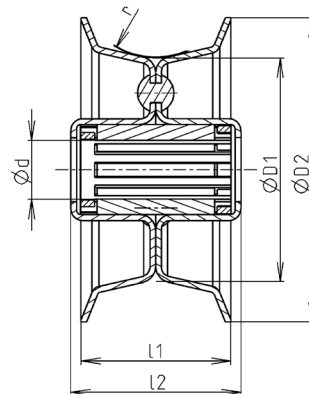
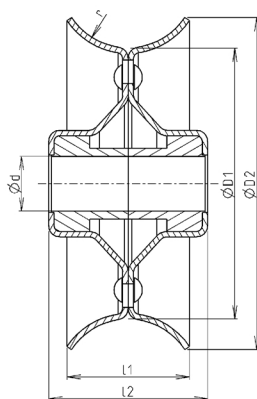

## KLADKY

### Kladky z lisovaného plechu





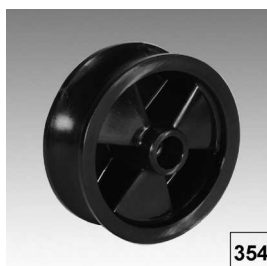
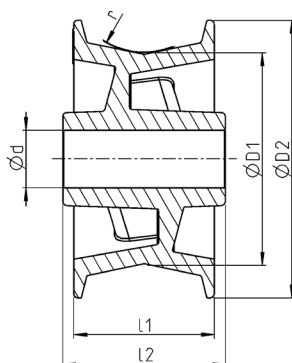

**353**

 Kladky ocelové z lisovaného plechu,  
pozinkované

	d		D1	D2	L1	L2	L3	r	 kg
KL-XA-V78	15		57	78	38	43,4	-	20	100
KL-XB-K130	20		99	122	45	58,4	-	25	250
KL-XB-V130	20		99	122	45	58,4	-	25	250
KL-XB-G130	20		99	122	45	58,4	-	25	250

### Kladky z polyamidu

**354**



Kladky z polyamidu

	d		D1	D2	L1	L2	L3	r	 kg
KL-PB-K55	15		57	75	38	44	-	20	100
KL-PB-K80	20		80	100	40	58	-	17	100
KL-PB-K100	20		102	122	45	60	-	21	200

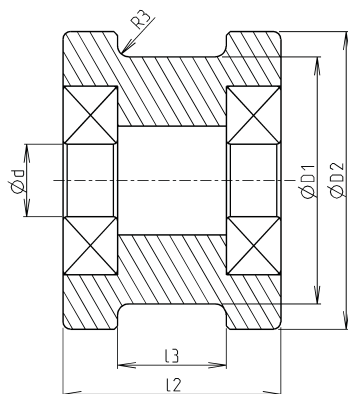
## Kladky z hliníkovej zliatiny

**354**

Kladky z hliníkovej zliatiny

	d		D1	D2	L1	L2	L3	r	 kg
KL-AL-G82-60-20-30-7	20	≡	68	82	-	60	30	-	2000
KL-AL-G82-60-20-42-7	20	≡	68	82	-	60	42	-	2000

## VI. MANIPULAČNÁ TECHNIKA TRANSPORTTECHNIK, MATERIAL-HANDLING TECHNIQUE

### Nízkozdvížené vozíky - typ NV 2300



356

Technické údaje NV 2300	Prevedenie
Celková šírka	520 /680/ mm
Šírka lyžíň	140/152/ mm
Zdvih hydr.jednotky	115 mm
Nosnosť	2300 kg
Rozmer pred.kolesa	175/180/ x 50 mm
Zadné koleso	82 x 65 mm
Celková výška	1210 mm
Celková dĺžka	340 + dĺžka lyžíň v mm
Hmotnosť	78 kg
Min.výška na podlahu	85 mm
Max.výška na podlahu	200 mm

Typ vozíka	Dĺžka lyžíň v mm	Typ použitých kolies/ Kolesá predné	Typ použitých kolies/ Kolesá zadné
NV 2300- 800/S-PA	800	celopolyamidové- CPZ	celopolyamidové- CPZ
NV 2300- 960/S-PA	960	celopolyamidové- CPZ	celopolyamidové- CPZ
NV 2300-1120/S-PA	1120	celopolyamidové- CPZ	celopolyamidové- CPZ
NV 2300-1500/S-PA	1500	celopolyamidové- CPZ	celopolyamidové- CPZ
NV 2300- 800/T-PA	800	celopolyamidové- CPZ	celopolyamidové- CPZ
NV 2300- 960/T-PA	960	celopolyamidové- CPZ	celopolyamidové- CPZ
NV 2300-1120/T-PA	1120	celopolyamidové- CPZ	celopolyamidové- CPZ
NV 2300-1500/T-PA	1500	celopolyamidové- CPZ	celopolyamidové- CPZ
NV 2300- 800/S-PA /PU	800	celopolyamidové- CPZ	Polyamid + polyuretán-PUZ
NV 2300- 960/S-PA/PU	960	celopolyamidové- CPZ	Polyamid + polyuretán-PUZ
NV 2300-1120/S-PA/PU	1120	celopolyamidové- CPZ	Polyamid + polyuretán-PUZ
NV 2300-1500/S-PA/PU	1500	celopolyamidové- CPZ	Polyamid + polyuretán-PUZ
NV 2300- 800/T-PA /PU	800	celopolyamidové- CPZ	Polyamid + polyuretán-PUZ
NV 2300- 960/T-PA/PU	960	celopolyamidové- CPZ	Polyamid + polyuretán-PUZ
NV 2300-1120/T-PA/PU	1120	celopolyamidové- CPZ	Polyamid + polyuretán-PUZ
NV 2300-1500/T-PA/PU	1500	celopolyamidové- CPZ	Polyamid + polyuretán-PUZ
NV 2300- 800/S-ALG/PA	800	Hliník + guma - ALE	celopolyamidové- CPZ
NV 2300- 960/S-ALG/PA	960	Hliník + guma - ALE	celopolyamidové- CPZ
NV 2300-1120/S-ALG/PA	1120	Hliník + guma - ALE	celopolyamidové- CPZ
NV 2300-1500/S-ALG/PA	1500	Hliník + guma - ALE	celopolyamidové- CPZ
NV 2300- 800/T-ALG/PA	800	Hliník + guma - ALE	celopolyamidové- CPZ
NV 2300- 960/T-ALG/PA	960	Hliník + guma - ALE	celopolyamidové- CPZ
NV 2300-1120/T-ALG/PA	1120	Hliník + guma - ALE	celopolyamidové- CPZ
NV 2300-1500/T-ALG/PA	1500	Hliník + guma - ALE	celopolyamidové- CPZ
NV 2300- 800/S-ALG/PA/PU	800	Hliník + guma - ALE	Polyamid + polyuretán-PUZ
NV 2300- 960/S-ALG/PA/PU	960	Hliník + guma - ALE	Polyamid + polyuretán-PUZ
NV 2300-1120/S-ALG/PA/PU	1120	Hliník + guma - ALE	Polyamid + polyuretán-PUZ
NV 2300-1500/S-ALG/PA/PU	1500	Hliník + guma - ALE	Polyamid + polyuretán-PUZ
NV 2300- 800/T-ALG/PA/PU	800	Hliník + guma - ALE	Polyamid + polyuretán-PUZ
NV 2300- 960/T-ALG/PA/PU	960	Hliník + guma - ALE	Polyamid + polyuretán-PUZ
NV 2300-1120/T-ALG/PA/PU	1120	Hliník + guma - ALE	Polyamid + polyuretán-PUZ
NV 2300-1500/T-ALG/PA/PU	1500	Hliník + guma - ALE	Polyamid + polyuretán-PUZ

## Vysokozdvížné vozíky - VV

**357**

Technické údaje/typ	VV 1000/1600	VV 1000/1200
Nosnosť	1000 kg	1 000 kg
Celková dĺžka	1592 mm	1592 mm
Celková šírka	717 mm	717 mm
Celková výška	1923 mm	1523 mm
Dĺžka lyžín	1170 mm	1170 mm
Šírka lyžín	540 mm	540 mm
Polomer natáčania	1500 mm	1500 mm
Min. výška nad podlahou	23 mm	23 mm
Hmotnosť	216 kg	200 kg
Zdvihová výška	90-1600 mm	90-1200 mm
Nosná plocha lyžín	1170x152 mm	1170x152 mm
Zdvih so záťažou / 1 kmit	20 mm	20 mm
Zdvih bez záťaže / 1 kmit	60 mm	60 mm

## Manipulačné vozíky - plošinové



358

**PLOŠINOVÝ VOZÍK**  
so snímateľnými bočnicami  
typ - PV-B 1000 x 700/600/



359

**PLOŠINOVÝ VOZÍK**  
s dvoma madlami  
typ - PV-2M 1000 x 700/600/



360

**PLOŠINOVÝ VOZÍK**  
s jedným madlom  
typ - PV-1M 1000 x 700/600/

Nosnosť vozíkov	350 kg
Kolesá - materiál	plech /polyamid/ + plná gumová obruč
Rozmer kolies/počet	Ø 160, Ø 200 /2x otočné, 2x pevné/
Plošina - rozmer/materiál	1000 x 700/600/ impregnované drevo, plech

## Skladové vozíky



361

**SV-2 na vrecia**

362

**SV-3 úzky**

363

**SV-4 na schody**

Označenie	SV-2 na vrecia	SV-3 úzky	SV-4 na schody	SV-9 na popolnice
Názov vozíka	skladový vozík na vrecia	skladový vozík úzky	skladový vozík na schody	skladový vozík na popolnice
Nosnosť	200 kg/400 kg	250kg	150 kg	150 kg
Výška x šírka	1060 x 400 mm	1130 x 540	1300 x 580 mm	1190 x 430 mm
Plošina - šírka x hĺbka	400 x 170 mm	280 x 250	330 x 170	--
Rozmer kolies	nafuk. Ø 260	nafuk. Ø 260	plné Ø 150 mm	plné Ø 200